

REVISIONS			
REV	DESCRIPTION	DATE	APPROVED
A	INITIAL RELEASE	12/29/09	D.N.

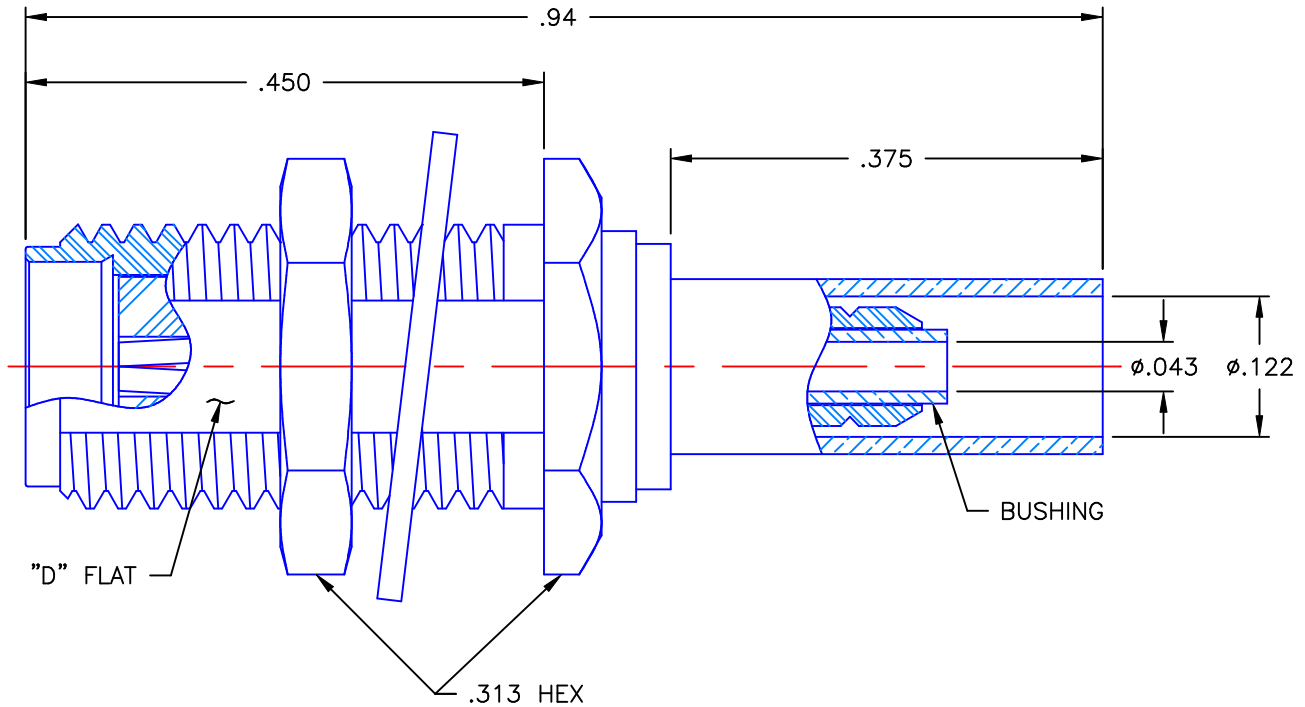

NOTES:

MATERIALS:

1. BODY & NUT = STAINLESS STEEL PER ASTM A582, ALLOY 303, CONDITION "A".
2. INSULATORS = VIRGIN WHITE TEFLON PER ASTM D1710, GRADE 1, TYPE I, CLASS "B".
3. CONTACT = BERYLLIUM COPPER PER ASTM B196, ALLOY C17300, TEMPER TD04.
4. LOCKWASHER = PHOSPHOR BRONZE PER ASTM B139, COPPER ALLOY C53400, TEMPER H04.
5. CRIMP SLEEVE = SEAMLESS LOWLEAD BRASS TUBE, ALLOY 330, SOFT ANNEAL TEMPER, .025/.060 GRAIN SIZE OR SEAMLESS COPPER TUBE PER ASTM B75, TYPE C12000, TEMPER: LIGHT ANNEAL O50 EXCEPT YIELD STRENGTH.
6. SHRINK SLEEVE = BLACK THERMOFIT SCL (NOT SHOWN).
7. BUSHING = BRASS PER ASTM B16, ALLOY C36000, TEMPER H02.

FINISHES:

1. BODY & NUT = PASSIVATE PER QQ-P-35, TYPE VI.
2. CONTACT = GOLD PLATE PER MIL-G-45204, TYPE II, CLASS 1, GRADE C, OVER .00010 TO .00020 STRESS FREE SULFAMATE NICKEL PER QQ-N-290.
3. LOCKWASHER & CRIMP SLEEVE = NICKEL PLATE PER QQ-N-290, CLASS 1, GRADE G, EXCEPT .0001 TO .0002 THICK OVER .00005 TO .0001 THICK COPPER PER MIL-C-14550.

Property of Radiall Incorporated
This document cannot be reproduced or
communicated to a third party without prior
written permission of RADIALL Incorporated.

UNLESS OTHERWISE SPECIFIED DIMENSIONS ARE IN INCHES TOLERANCES ON	DWN:	DATE	 APPLIED ENGINEERING PRODUCTS 104 John W. Murphy Dr. New Haven, CT 06513
	D.N.	12/29/09	
DECIMAL	ANGLE	DATE	
		A.D.M.	12/29/09
		APVD:	DATE
		J.M.	12/29/09
REFERENCE:	MATERIALS & FINISHES:	SIZE	FSCM NO.
ORIGINATOR: D.N.	SEE NOTES	A	19505
DATE: 12/29/09		DWG. NO.	9030-9023-002
		REV	A
		SCALE	6:1
		SHEET	1 OF 1

9030-9023-002