



SANYO Semiconductors

DATA SHEET

An ON Semiconductor Company

LV8481CS — Bi-CMOS IC Saturated Driver with 2 channels + Constant Current Driver

Overview

The LV8481CS is low-voltage motor driver with a saturated driver with 2 channels + constant current driver. Since it is in wafer level package, this IC is optimized for the stepping motor driver and shutter driver of various portable equipments including the mobile phones with camera.

Functions

- Saturated driver H bridge with 2 channels + Constant current driver.
- I²C bus interface
- Built-in AF stepping motor sequence logic (enabling 2-phase excitation and 1-2 phase excitation)
- Built-in lens home position sequence logic
- Enabling power-saving by MOS process
- Built-in 4 bit DAC for constant current
- Built-in constant current detection resistance
- Wafer level package. WLP10 (0.97mm × 2.47mm × 0.5mm)
- Built-in thermal shutdown circuit and LVS circuit.

Specifications

Absolute Maximum Ratings at Ta = 25°C

Parameter	Symbol	Conditions	Ratings	Unit
Maximum supply voltage	V _{CC} , VM max		5.0	V
Output applied voltage	V _{OUT} max	OUT1, OUT2, OUT3, OUT4, OUT5	5.0	V
Input applied voltage	V _{IN} max	ENA, SCL, SDA	-0.3 to +5.0	V
GND pin flow-out current	IGND	Per channel	400	mA
Allowable power dissipation	Pd max	With specified substrate *	550	mW
Operating temperature	Topr		-30 to +85	°C
Storage temperature	Tstg		-40 to +150	°C

* Specified substrate : 50.0mm × 50.0mm × 1.6mm, glass epoxy 1 layers printed circuit board

■ Any and all SANYO Semiconductor Co.,Ltd. products described or contained herein are, with regard to "standard application", intended for the use as general electronics equipment (home appliances, AV equipment, communication device, office equipment, industrial equipment etc.). The products mentioned herein shall not be intended for use for any "special application" (medical equipment whose purpose is to sustain life, aerospace instrument, nuclear control device, burning appliances, transportation machine, traffic signal system, safety equipment etc.) that shall require extremely high level of reliability and can directly threaten human lives in case of failure or malfunction of the product or may cause harm to human bodies, nor shall they grant any guarantee thereof. If you should intend to use our products for applications outside the standard applications of our customer who is considering such use and/or outside the scope of our intended standard applications, please consult with us prior to the intended use. If there is no consultation or inquiry before the intended use, our customer shall be solely responsible for the use.

■ Specifications of any and all SANYO Semiconductor Co.,Ltd. products described or contained herein stipulate the performance, characteristics, and functions of the described products in the independent state, and are not guarantees of the performance, characteristics, and functions of the described products as mounted in the customer's products or equipment. To verify symptoms and states that cannot be evaluated in an independent device, the customer should always evaluate and test devices mounted in the customer's products or equipment.

LV8481CS

Allowable Operating Conditions at $T_a = 25^\circ\text{C}$

Parameter	Symbol	Conditions	Ratings	Unit
Supply voltage	V_{CC}		2.4 to 4.5	V
High level input voltage	V_{IH}	ENA, SCL and SDA	$0.4 \times V_{CC}$ to	V
Low level input voltage	V_{IL}		to $V_{CC} \times 0.13$	V

Electrical Characteristics at $T_a = 25^\circ\text{C}$, $V_{CC} = 2.8\text{V}$

Parameter	Symbol	Conditions	Ratings			Unit
			min	typ	max	
Supply current	I_{CCO}	EN = 0V		0.1	1	μA
	I_{CCO1}	EN = 3V		1.2	1.8	mA
Output ON resistance 1 (out1 to out3)	Ron11	$V_{CC} = 3.0\text{V}$ (Sum of the upper and lower side outputs) EN = 3.0V, $I_{OUT} = 100\text{mA}$		2.7	3.3	Ω
	Ron12	$V_{CC} = 4.5\text{V}$ (Sum of the upper and lower side outputs) EN = 3.0V, $I_{OUT} = 100\text{mA}$		2.1	2.6	Ω
Output ON resistance 2 (out4 to out5 + sence R)	Ron21	$V_{CC} = 3.0\text{V}$ (Sum of the upper and lower side outputs + RF (0.5 Ω)) EN = 3.0V, $I_{OUT} = 100\text{mA}$		2.7	3.2	Ω
	Ron22	$V_{CC} = 4.5\text{V}$ (Sum of the upper and lower side outputs + RF (0.5 Ω)) EN = 3.0V, $I_{OUT} = 100\text{mA}$		2.1	2.55	Ω
Output constant current DAC1	I_{OUT1}	D3-D0code : 0000		260		mA
Output constant current DAC2	I_{OUT2}	D3-D0code : 0001		250		mA
Output constant current DAC3	I_{OUT3}	D3-D0code : 0010		240		mA
Output constant current DAC4	I_{OUT4}	D3-D0code : 0011		230		mA
Output constant current DAC5	I_{OUT5}	D3-D0code : 0100		220		mA
Output constant current DAC6	I_{OUT6}	D3-D0code : 0101		210		mA
Output constant current DAC7	I_{OUT7}	D3-D0code : 0110		200		mA
Output constant current DAC8	I_{OUT8}	D3-D0code : 0111		190		mA
Output constant current DAC9	I_{OUT9}	D3-D0code : 1000		180		mA
Output constant current DAC10	I_{OUT10}	D3-D0code : 1001		170		mA
Output constant current DAC11	I_{OUT11}	D3-D0code : 1010		160		mA
Output constant current DAC12	I_{OUT12}	D3-D0code : 1011		150		mA
Output constant current DAC13	I_{OUT13}	D3-D0code : 1100		140		mA
Output constant current DAC14	I_{OUT14}	D3-D0code : 1101		130		mA
Output constant current DAC15	I_{OUT15}	D3-D0code : 1110		120		mA
Output constant current DAC16	I_{OUT16}	D3-D0code : 1111		110		mA
Output turn ON time	Traise	OUT1-OUT4		1	3	μs
Output turn OFF time	Tfall	OUT1-OUT4		0.2	1	μs
AF PLS period	Taf		1.8	2	2.2	ms
Input curren	I_{IN}	$V_{IN} = 3\text{V}$		0	1	μA
SDA pin low level output	V_{OL}	$I_O = 300\mu\text{A}$		0.2	0.3	V
Time of onset of movements after receiving I ² C communication	TI ² CSH	I ² C comand SH operation			10	μs
	TI ² CAF	I ² C comand AF sequence operation			1.2	ms
	TI ² CDP	I ² C comand Defaultposition sequence operation			6	ms
Thermal shut down operation temperature	TTSD	ENA = 3V Design target value		175		$^\circ\text{C}$
Hysteresis	T Δ TSD	ENA = 3V Design target value		35		$^\circ\text{C}$

(Assured design target) * : Design target value, not to be measured at production test.

LV8481CS

Package Dimensions

unit : mm (typ)
3362

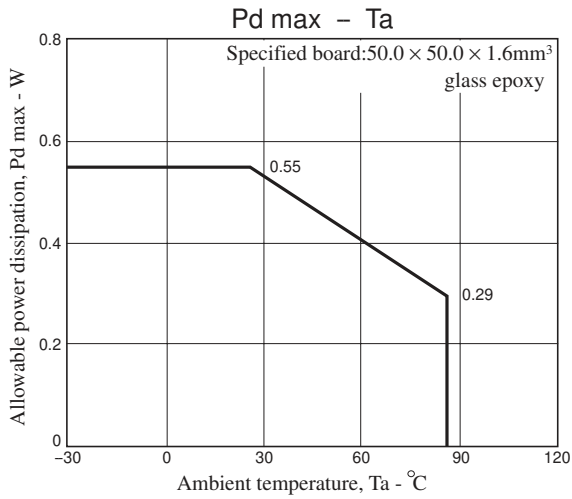
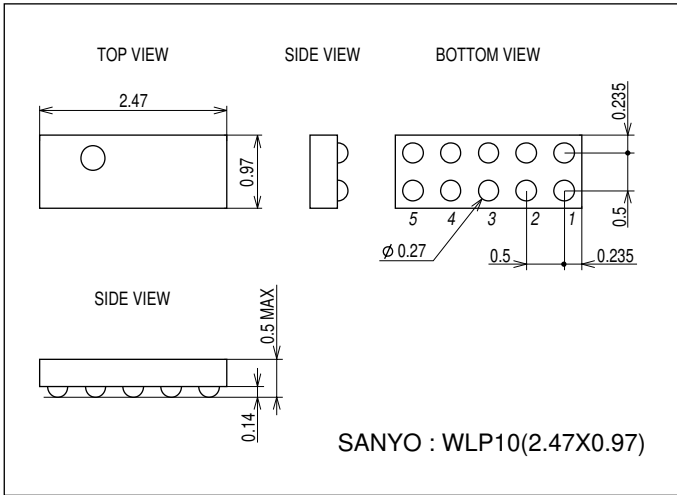

Pin Assignment

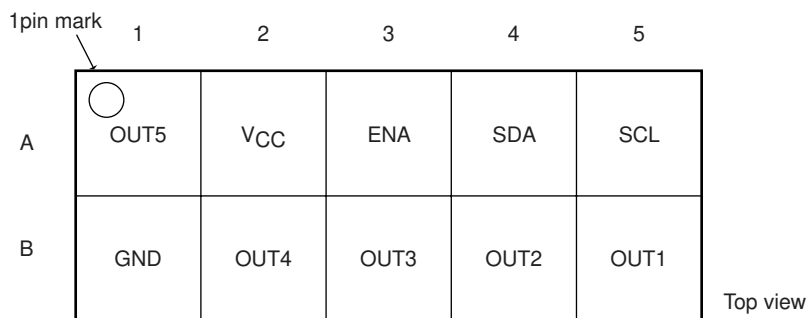
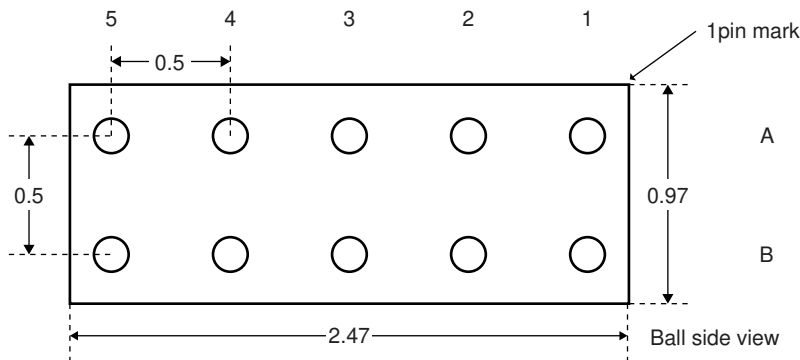

Pin No.	Pin Name
A1	OUT5
A2	VCC
A3	ENA
A4	SDA
A5	SCL
B1	GND
B2	OUT4
B3	OUT3
B4	OUT2
B5	OUT1

LV8481CS

Block Diagram

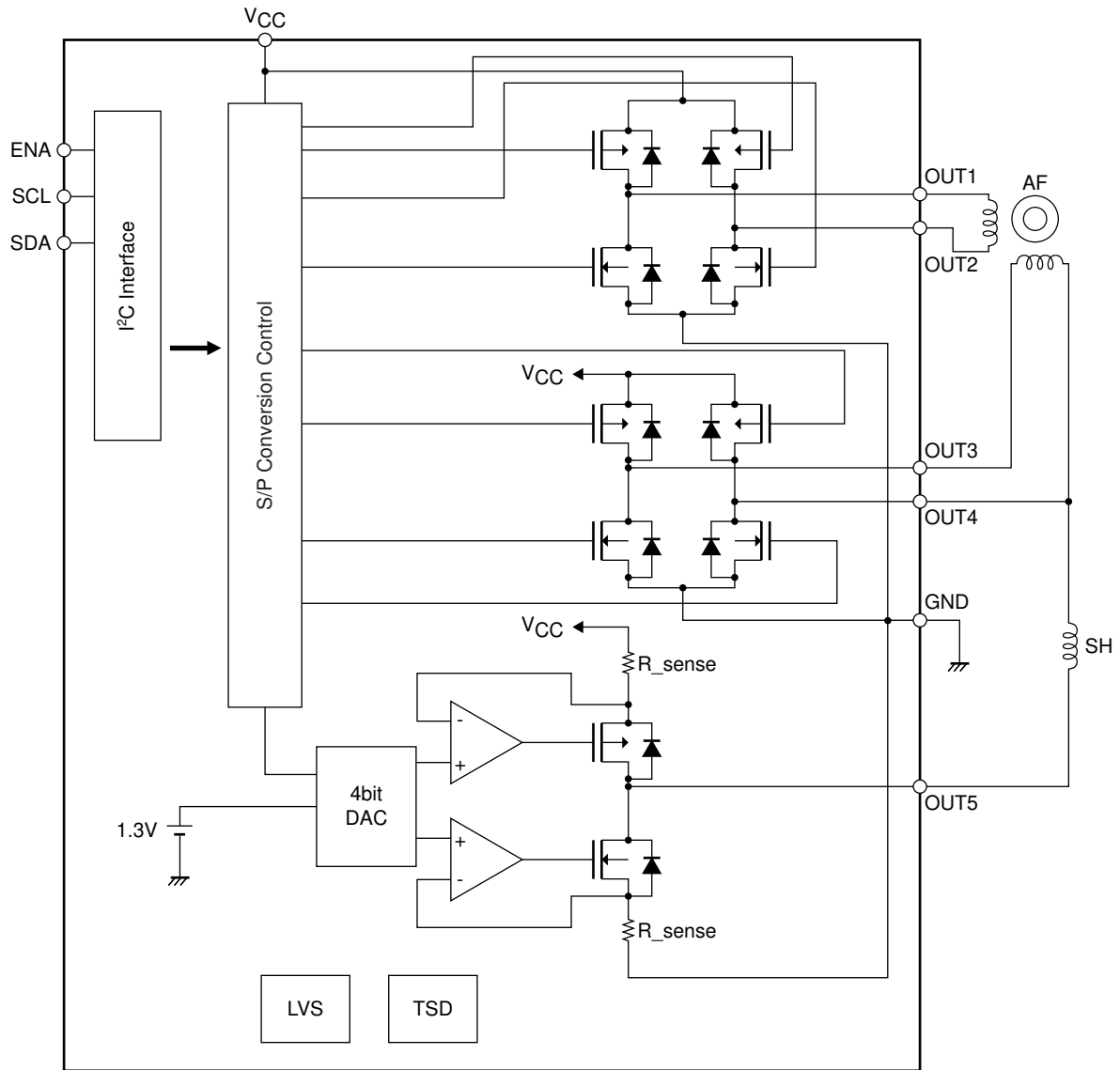

LV8481CS

Serial Bus Communication Specifications

I²C serial transfer timing conditions

Standard mode

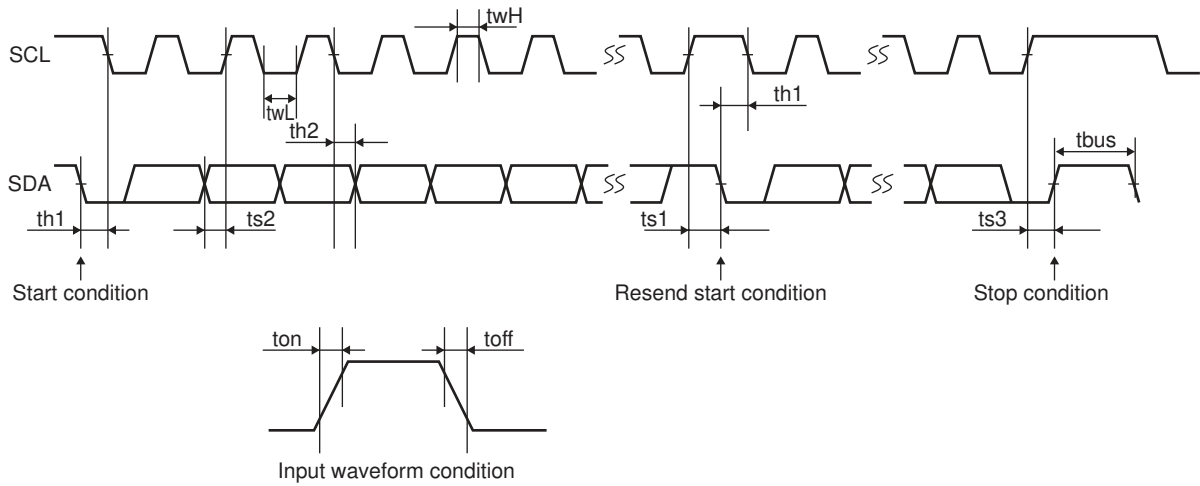

Standard mode

Parameter	symbol	Conditions	min	typ	max	unit
SCL clock frequency	fscL	SCL clock frequency	0		100	kHz
Data setup time	ts1	Setup time of SCL with respect to the falling edge of SDA	4.7			us
	ts2	Setup time of SDA with respect to the rising edge of SCL	250			ns
	ts3	Setup time of SCL with respect to the rising edge of SDA	4.0			us
Data hold time	th1	Hold time of SDA with respect to the falling edge of SDA	4.0			us
	th2	Hold time of SDA with respect to the falling edge of SCL	0			us
Pulse width	twL	SCL low period pulse width	4.7			us
	twH	SCL high period pulse width	4.0			us
Input waveform conditions	ton	SCL, SDA (input) rising time			1000	ns
	toff	SCL, SDA (input) falling time			300	ns
Bus free time	tbus	Interval between stop condition and start condition	4.7			us

High-speed mode

Parameter	Symbol	Conditions	min	typ	max	unit
SCL clock frequency	fscL	SCL clock frequency	0		400	kHz
Data setup time	ts1	Setup time of SCL with respect to the falling edge of SDA	0.6			us
	ts2	Setup time of SDA with respect to the rising edge of SCL	100			ns
	ts3	Setup time of SCL with respect to the rising edge of SDA	0.6			us
Data hold time	th1	Hold time of SDA with respect to the falling edge of SDA	0.6			us
	th2	Hold time of SDA with respect to the falling edge of SCL	0.08			us
Pulse width	twL	SCL low period pulse width	1.3			us
	twH	SCL high period pulse width	0.6			us
Input waveform conditions	ton	SCL, SDA (input) rising time			300	ns
	toff	SCL, SDA (input) falling time			300	ns
Bus free time	tbus	Interval between stop condition and start condition	1.3			us

LV8481CS

I²C bus transmission method

Start and stop conditions

The I²C bus requires that the state of SDA be preserved while SCL is high as shown in the timing diagram below during a data transfer operation.

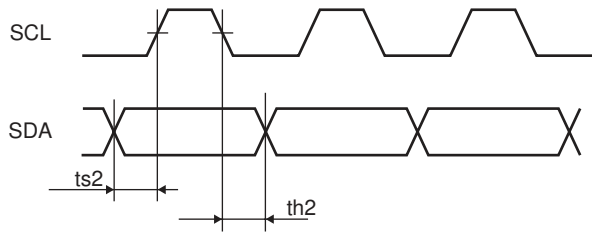

When data is not being transferred, both SCL and SDA are in the high state. The start condition is generated and access is started when SDA is changed from high to low while SCL and SDA are high. Conversely, the stop condition is generated and access is ended when SDA is changed from low to high while SCL is high.

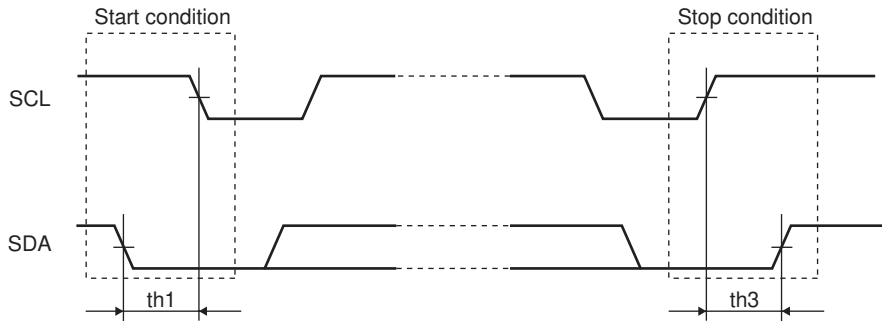

Data transfer and acknowledgement response

After the start condition has been generated, the data is transferred one byte (8 bits) at a time. Generally, in an I²C bus, a unique 7-bit slave address is assigned to each device, and the first byte of the transfer data is allocated to the 7-bit slave address and to the command (R/W) indicating the transfer direction of the subsequent data.

Every time 8 bits of data for each byte are transferred, the ACK signal is sent from the receiving end to the sending end. Immediately after the clock pulse of SCL bit 8 in the data transferred has fallen to low, SDA at the sending end is released, and SDA is set to low at the receiving end, causing the ACK signal to be sent.

When, after the receiving end has sent the ACK signal, the transfer of the next byte remains in the receiving status, the receiving end releases SDA at the falling edge of the ninth SCL clock.

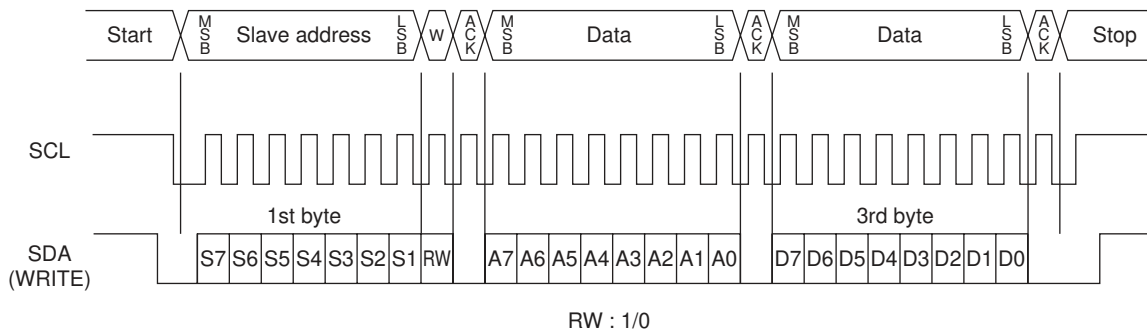

Number of Slave Address is 0110010. (S7→S1)

LV8481CS

Serial Map

Register Address								Data							
A7	A6	A5	A4	A3	A2	A1	A0	D7	D6	D5	D4	D3	D2	D1	D0
0	0	0	0	0	0	0	0	AFMODE [7 : 0]							
								0	0	0	0	0	0	0	0
0	0	0	0	0	0	0	1	FL	x	AFMODE [5 : 3]			HOLD time set [2 : 0]		
								0	0	0	0	0	0	0	0
1	0	0	0	0	0	1	0	x	x	x	x	x	SHMODE [2 : 0]		
								0	0	0	0	0	0	0	0
0	0	0	0	0	0	1	1	x	x	x	x	CURRENTMODE [3 : 0]			
								0	0	0	0	0	0	0	0

Upper : Register name Lower : Default value

*Caution : address 00000111 is IC testmode. This address is out of use.

Serial Each Mode Settings

Rotational Direction Setting

0	0	0	0	0	0	0	0	0	0	D7	D6	D5	D4	D3	D2	D1	D0
---	---	---	---	---	---	---	---	---	---	----	----	----	----	----	----	----	-----------

D0	Rotational direction
0	CW
1	CCW

AF ON/OFF Setting

0	0	0	0	0	0	0	0	0	0	D7	D6	D5	D4	D3	D2	D1	D0
---	---	---	---	---	---	---	---	---	---	----	----	----	----	----	----	-----------	----

D1	ON/OFF
0	Standby mode
1	Operation mode

AF counter Reset

0	0	0	0	0	0	0	0	0	0	D7	D6	D5	D4	D3	D2	D1	D0
---	---	---	---	---	---	---	---	---	---	----	----	----	----	----	-----------	----	----

D2	Counter Reset
0	Reset on
1	Reset off

LV8481CS

Step Number Setting

0	0	0	0	0	0	0	0	0	0	D7	D6	D5	D4	D3	D2	D1	D0
---	---	---	---	---	---	---	---	---	---	----	----	----	----	----	----	----	----

D7 (32P)	D6 (16P)	D5 (8P)	D4 (4P)	D3 (2P)	Number of steps
0	0	0	0	0	2step
0	0	0	0	1	4step
0	0	0	1	0	6step
0	0	0	1	1	8step
0	0	1	0	0	10step
0	0	1	0	1	12step
0	0	1	1	0	14step
0	0	1	1	1	16step
0	1	0	0	0	18step
0	1	0	0	1	20step
0	1	0	1	0	22step
0	1	0	1	1	24step
0	1	1	0	0	26step
0	1	1	0	1	28step
0	1	1	1	0	30step
0	1	1	1	1	32step
1	0	0	0	0	34step
1	0	0	0	1	36step
1	0	0	1	0	38step
1	0	0	1	1	40step
1	0	1	0	0	42step
1	0	1	0	1	44step
1	0	1	1	0	46step
1	0	1	1	1	48step
1	1	0	0	0	50step
1	1	0	0	1	52step
1	1	0	1	0	54step
1	1	0	1	1	56step
1	1	1	0	0	58step
1	1	1	0	1	60step
1	1	1	1	0	62step
1	1	1	1	1	64step

Note):

- D3 : 2Pulse on/off (2step) setting register
- D4 : 4Pulse on/off (4step) setting register
- D5 : 8Pulse on/off (8step) setting register
- D6 : 16Pulse on/off (16step) setting register
- D7 : 32Pulse on/off (32step) setting register

LV8481CS

AF HOLDTIME Setting

0	0	0	0	0	0	0	0	0	1	D7	D6	D5	D4	D3	D2	D1	D0
---	---	---	---	---	---	---	---	---	---	----	----	----	----	----	----	----	----

D2	D1	D0	HOLD PULSE Number 1 (at AF sequence)	HOLD PULSE Number (at Default position sequence)
0	0	0	1Puls (2msec/1msec)	1Puls (10msec/5msec)
0	0	1	2Puls (4msec/2msec)	2Puls (20msec/10msec)
0	1	0	4Puls (8msec/4msec)	4Puls (40msec/20msec)
0	1	1	5Puls (10msec/5msec)	5Puls (50msec/25msec)
1	0	0	8Puls (16msec/8msec)	8Puls (80msec/40msec)
1	0	1	16Puls (32msec/16msec)	16Puls (160msec/80msec)
1	1	0	32Puls (64msec/32msec)	32Puls (320msec/160msec)
1	1	1	1Puls (2msec/1msec)	1Puls (10msec/5msec)

Note) : HOLDTIME value make a written (2-phase excitation/1-2 phase excitation).

AF Excitation Setting

0	0	0	0	0	0	0	0	1	D7	D6	D5	D4	D3	D2	D1	D0
---	---	---	---	---	---	---	---	---	----	----	----	----	----	----	----	----

D3	Excitation system
0	2-phase excitation
1	1-2 phase excitation

Default position sequence setting

0	0	0	0	0	0	0	0	1	D7	D6	D5	D4	D3	D2	D1	D0
---	---	---	---	---	---	---	---	---	----	----	----	----	----	----	----	----

D4	ON/OFF
0	Off
1	Default position sequence ON

Default position and AF sequence + steps Setting

0	0	0	0	0	0	0	0	1	D7	D6	D5	D4	D3	D2	D1	D0
---	---	---	---	---	---	---	---	---	----	----	----	----	----	----	----	----

D5	+64step (on/off)
0	Off
1	+64step

Further note : When the pulses of 64 steps or more in total are set in Default position sequence and AF sequence and the flag of D5 is "1", the pulse of the number of AFsteps + 64steps can be set.

AF sequence and Default position sequence Flag

0	0	0	0	0	0	0	0	1	D7	D6	D5	D4	D3	D2	D1	D0
---	---	---	---	---	---	---	---	---	----	----	----	----	----	----	----	----

The situation between Standby state and Under execution of the sequences AF and Default position can be confirmed in the state of "D7".

D7	FL
0	Standby state
1	Under execution

When the sequence ends, FL automatically becomes zero.

LV8481CS

AF sequence diagram

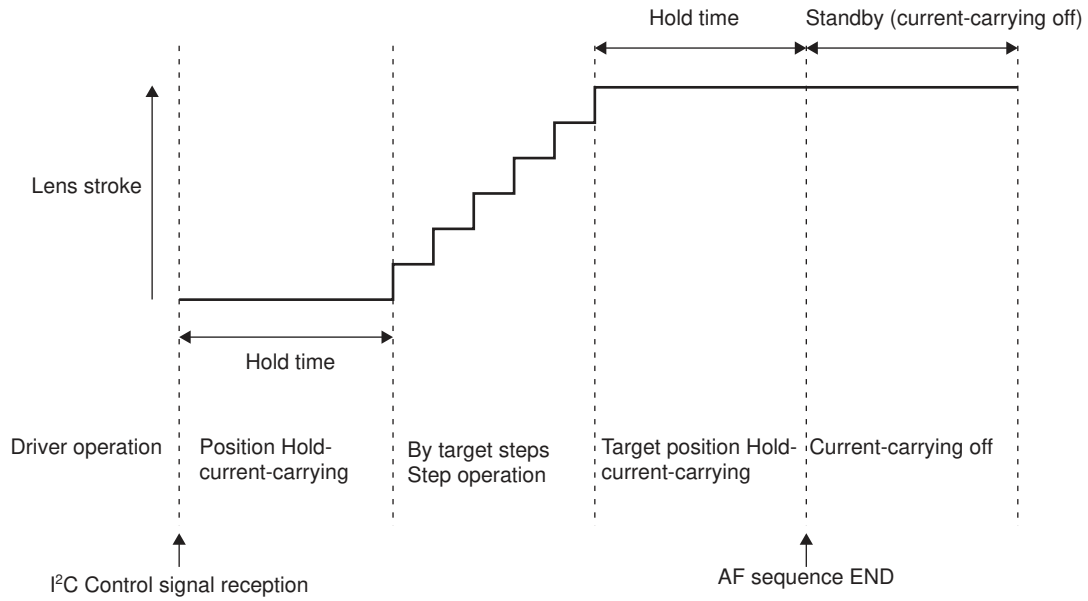

- (1) Set default value at OUT1 = H, OUT2 = L, OUT3 = H and OUT4 = L.
- (2) STMspeed at the AF sequence becomes 500pps.
- (3) The hold current-carrying time, it is the same time both front and rear times.

Default Position Sequence diagram

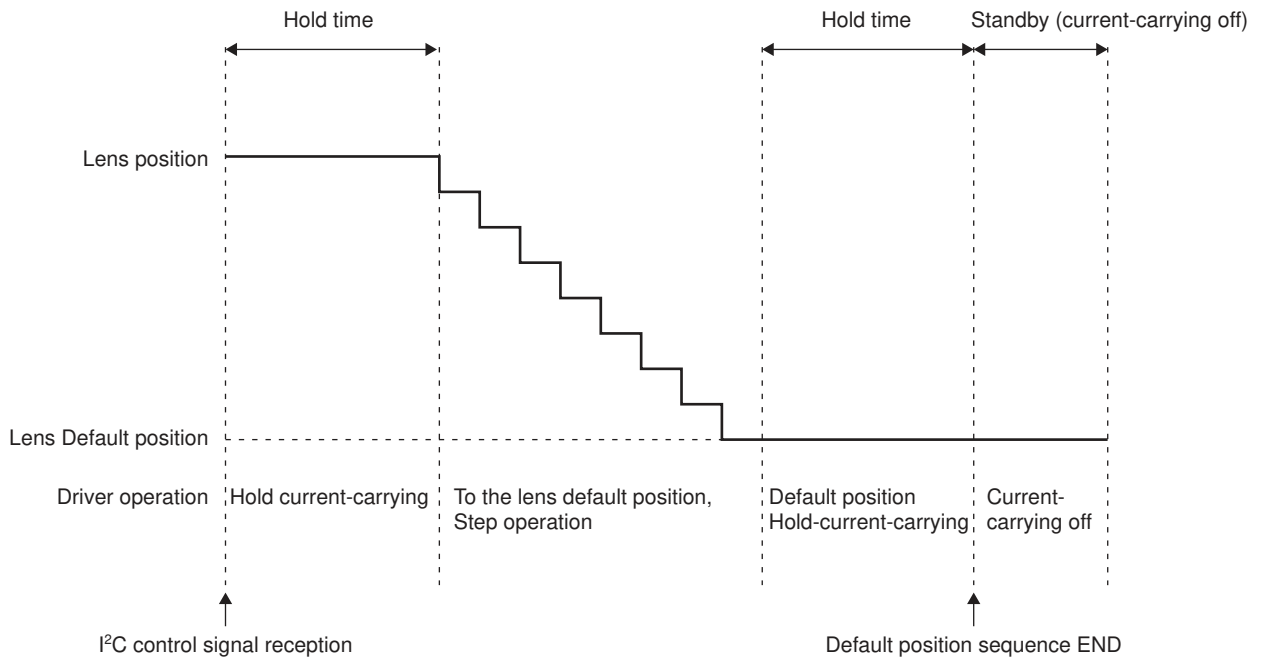

Further note : (1) When the flag of D4 in the address 00000001 of a default position sequence is "1", whether or not the total of a default position sequence is 65step or more is set by using a flag in D5. The command is transmitted by the I²C communication after setting HOLD time.

- (2) The number of step, the rotational direction and AFon/off are set in the address 00000000. And, a default position sequence is performed at the IC side when the data is transmitted by using I²C communication.
- (3) STMspeed in a default position sequence becomes 100pps.
- (4) Hold current-carrying time, it becomes congruent with the previous or nest time.

LV8481CS

SH bridge, OUT4 to 5 Operation Setting

1	0	0	0	0	0	0	1	0	D7	D6	D5	D4	D3	D2	D1	D0
---	---	---	---	---	---	---	---	---	----	----	----	----	----	----	----	----

D1	D0	OUT4	OUT5	Bridge state
0	0	Z	Z	Standby All channels OFF
0	1	H	L	Constant current between OUT4 and OUT5
1	0	L	H	Constant current between OUT5 and OUT4
1	1	L	L	Brake Logic

- Constant current is driven When applying current between channels OUT4 and OUT5.

SH bridge, on/off Setting

1	0	0	0	0	0	0	1	0	D7	D6	D5	D4	D3	D2	D1	D0
---	---	---	---	---	---	---	---	---	----	----	----	----	----	----	----	----

D2	ON/OFF
0	Standby
1	Operation

Constant Current Setting

1	0	0	0	0	0	0	1	1	D7	D6	D5	D4	D3	D2	D1	D0
---	---	---	---	---	---	---	---	---	----	----	----	----	----	----	----	----

D3	D2	D1	D0	Constant current value
0	0	0	0	260mA
0	0	0	1	250mA
0	0	1	0	240mA
0	0	1	1	230mA
0	1	0	0	220mA
0	1	0	1	210mA
0	1	1	0	200mA
0	1	1	1	190mA
1	0	0	0	180mA
1	0	0	1	170mA
1	0	1	0	160mA
1	0	1	1	150mA
1	1	0	0	140mA
1	1	0	1	130mA
1	1	1	0	120mA
1	1	1	1	110mA

LV8481CS

AF sequence (2-phase excitation drive) (1 cycle = 4CLK)

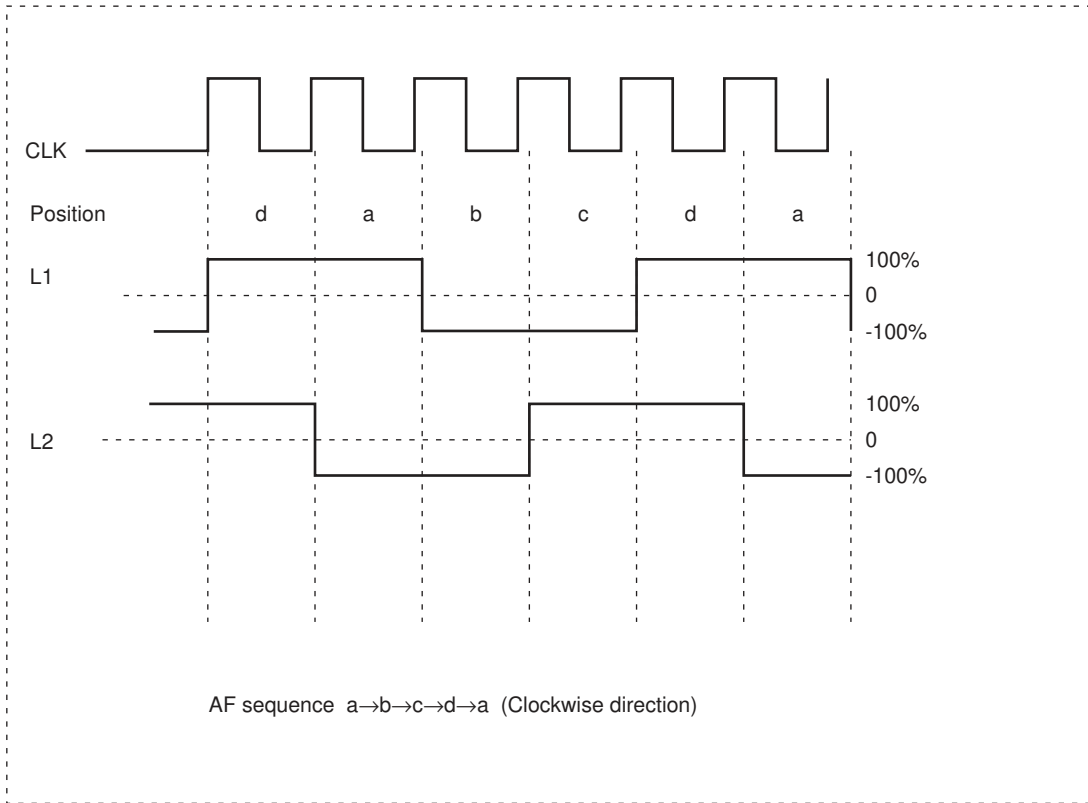

AF sequence (1-2 phase excitation drive) (1 cycle = 8CLK)

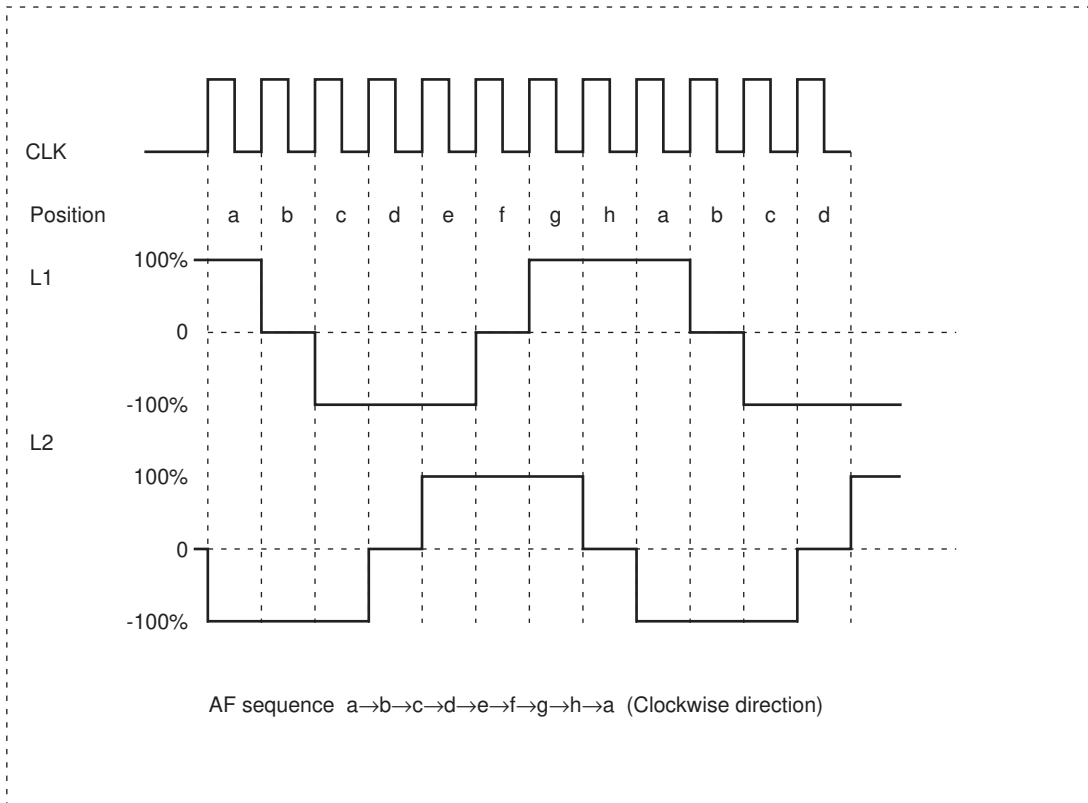

- SANYO Semiconductor Co.,Ltd. assumes no responsibility for equipment failures that result from using products at values that exceed, even momentarily, rated values (such as maximum ratings, operating condition ranges, or other parameters) listed in products specifications of any and all SANYO Semiconductor Co.,Ltd. products described or contained herein.
- SANYO Semiconductor Co.,Ltd. strives to supply high-quality high-reliability products, however, any and all semiconductor products fail or malfunction with some probability. It is possible that these probabilistic failures or malfunction could give rise to accidents or events that could endanger human lives, trouble that could give rise to smoke or fire, or accidents that could cause damage to other property. When designing equipment, adopt safety measures so that these kinds of accidents or events cannot occur. Such measures include but are not limited to protective circuits and error prevention circuits for safe design, redundant design, and structural design.
- In the event that any or all SANYO Semiconductor Co.,Ltd. products described or contained herein are controlled under any of applicable local export control laws and regulations, such products may require the export license from the authorities concerned in accordance with the above law.
- No part of this publication may be reproduced or transmitted in any form or by any means, electronic or mechanical, including photocopying and recording, or any information storage or retrieval system, or otherwise, without the prior written consent of SANYO Semiconductor Co.,Ltd.
- Any and all information described or contained herein are subject to change without notice due to product/technology improvement, etc. When designing equipment, refer to the "Delivery Specification" for the SANYO Semiconductor Co.,Ltd. product that you intend to use.
- Information (including circuit diagrams and circuit parameters) herein is for example only; it is not guaranteed for volume production.
- Upon using the technical information or products described herein, neither warranty nor license shall be granted with regard to intellectual property rights or any other rights of SANYO Semiconductor Co.,Ltd. or any third party. SANYO Semiconductor Co.,Ltd. shall not be liable for any claim or suits with regard to a third party's intellectual property rights which has resulted from the use of the technical information and products mentioned above.

This catalog provides information as of December, 2009. Specifications and information herein are subject to change without notice.