

MATERIAL: BRASS

WIRE SIZE: 24-28 AWG

NOTE #1: CONTACTS SUPPLIED ON 10,000 PC REEL
 NOTE #2: RECOMMENDED MAX. INSULATION DIAMETER FOR 24-28 AWG IS 0.035".

GOLD PLATING THICKNESS IS BETWEEN 1u" AND 1.5u"

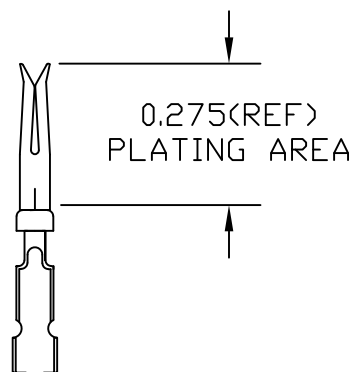

PLATING:	WIRE SIZE
	24-28
GOLD FLASH ON MATING AREA NICKEL ON WIRE CRIMP	170-002-170L001
.000010" GOLD OVER .000050" NICKEL ENTIRE CONTACT	170-002-170L002
.000030" GOLD OVER .000100" NICKEL ENTIRE CONTACT	170-002-170L003

RoHS COMPLIANT

UNITS = inch

DO NOT SCALE FROM DRAWING



THESE DRAWINGS AND SPECIFICATIONS ARE THE PROPERTY OF NorComp AND SHALL NOT BE REPRODUCED, COPIED OR USED AS THE BASIS FOR THE MANUFACTURE OR SALE OF APPARATUS WITHOUT WRITTEN PERMISSION.

DRAWN:
PAM JENKINS
DATE:
05/28/2002

NorComp

SCALE: NTS	SHEET 1	OF 2	REV 4
DWG NO.		170-002-170L00Y	

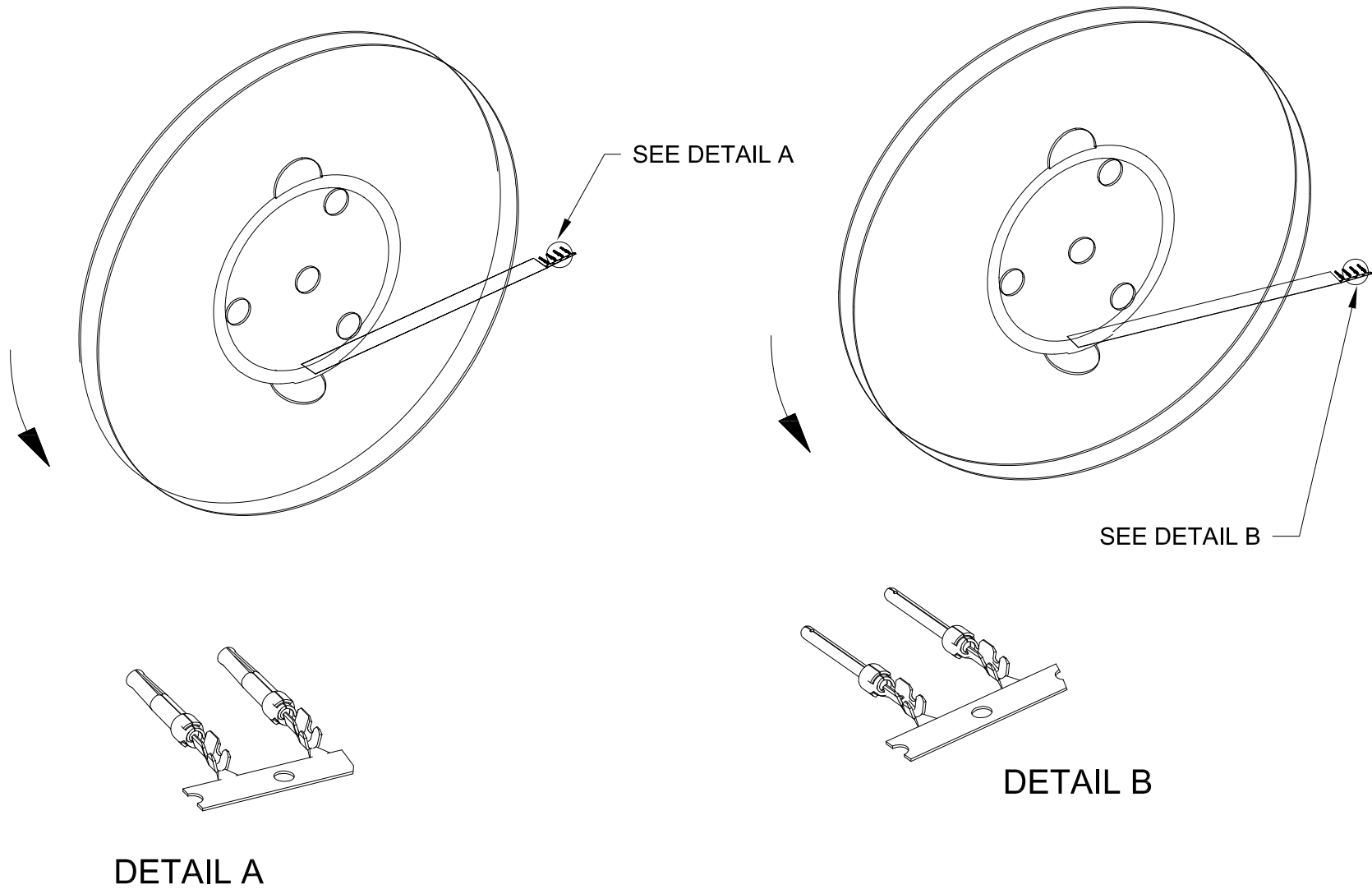

RoHS COMPLIANT

UNITS = inch

DO NOT SCALE FROM DRAWING



THESE DRAWINGS AND SPECIFICATIONS ARE THE PROPERTY OF NorComp AND SHALL NOT BE REPRODUCED, COPIED OR USED AS THE BASIS FOR THE MANUFACTURE OR SALE OF APPARATUS WITHOUT WRITTEN PERMISSION.

DRAWN:
PAM JENKINS
DATE:
05/28/2002

NorComp

SCALE: NTS	SHEET 2	OF 2	REV 4
DWG NO.		170-002-170L00Y	