

NOTES:

1. PACKAGE CABLE ASSEMBLY IN BAG. TAG IN BAG WITH "AMPHENOL RF, 95-909-155-XXX & WWYY".
2. CABLE ASSEMBLY TO BE 100% TESTED FOR HI-POT, CONTINUITY, SHORTS AND OPENS.
3. FOR STRIPPING DIMENSIONS AND ASSEMBLY INSTRUCTIONS SEE END CONNECTOR PRINTS.

THIRD ANGLE PROJ.

REVISIONS

REV	DESCRIPTION	DATE	ECO	APPR
A	RELEASE TO MFG.	24-Oct-16	2224	AG

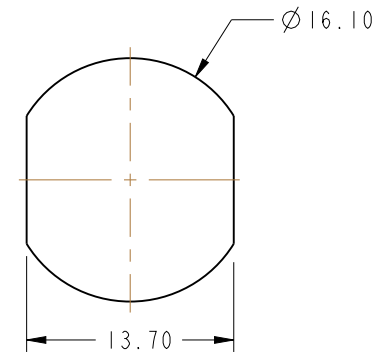

RECOMMENDED MOUNTING HOLE DIMENSIONS

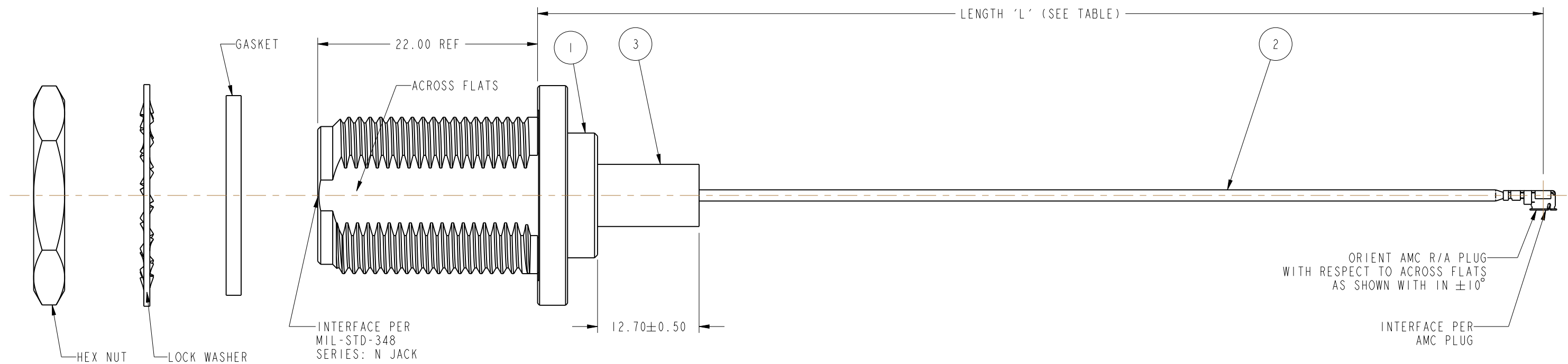
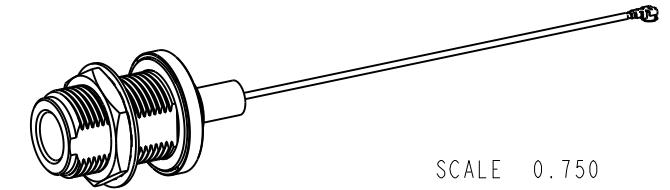

DESIGN REQUIREMENTS:

- | | |
|--|---|
| <input checked="" type="checkbox"/> FREQUENCY: DC TO 6 GHz | <input checked="" type="checkbox"/> CONTINUITY |
| <input type="checkbox"/> VSWR: ---- MAX. | <input checked="" type="checkbox"/> HI-POT : 200 VRMS |
| <input type="checkbox"/> INS. LOSS: ---- dB MAX. | <input type="checkbox"/> OTHER |

95-909-155-006	300.00±5.00
95-909-155-005	250.00±5.00
95-909-155-004	200.00±5.00
95-909-155-003	150.00±3.00
95-909-155-002	100.00±3.00
95-909-155-001	50.00±3.00
PART NUMBER	LENGTH 'L' IN MM

9-954-359	0.042 FT	3	HEAT SHRINK TUBE	BLACK
A-1PA-178-630N2	0.50	2	CABLE ASSY	
172313	1	1	ASSEMBLY	
PART NUMBER	QTY.	ITEM	DESCRIPTION	FINISH

UNLESS OTHERWISE SPECIFIED, DIMENSIONS ARE IN METRIC AND TOLERANCES ARE:
 <0.5mm ±0.05mm 0.5 - 6mm ±0.1mm 6 - 30mm ±0.2mm 30 - 120mm ±0.3mm ANGLES ±1°

NOTICE - These drawings, specifications, or other data (1) are, and remain the property of Amphenol corp. (2) must be returned upon request; and (3) are confidential and not to be disclosed to any person other than those to whom they are given by Amphenol Corp. the furnishing of these drawings, specifications, or other data by Amphenol Corp., or to any other person to anyone for any purpose is not to be regarded by implication or otherwise in any manner licensing, granting rights to permitting such holder or any other person to manufacture, use or sell any product, process or design, patented or otherwise, that may in any way be related to or disclosed by said drawings, specifications, or other data.

MATERIAL	DRAWN MADHAN G	DATE 15-Apr-16	TITLE N STR BHD CRIMP JACK TO AMC R/A PLUG USING RG 178 CABLE, VARIOUS LENGTH		Amphenol RF www.amphenolrf.com	
REFERENCE EAR # 7180	ENGINEER MADHAN G	DATE 15-Apr-16				
CONFIGURATION LEVEL: In Work	APPROVED K.CAPOZZI	DATE 24-Oct-16	SCALE: 2.5:1.0	SHEET 1 OF 1	DRAWING NO.95-909-155-XXX	
FINISH	CAD FILE		DWG SIZE B	REV A	ITEM NO.95-909-155-XXX	
					PART NO.95-909-155-XXX	