

Slotted Optical Switch

OPB854A1, OPB854A2, OPB854A3,
OPB854B1, OPB854B2, OPB854B3

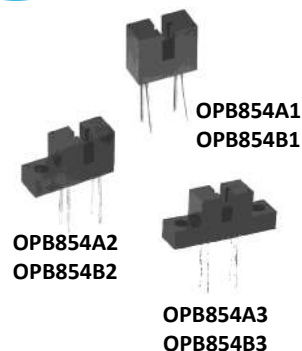

Features:

- Opaque housing material for ambient light rejection
- Non-contact switching
- Printed circuit board mounting, lead spacing 0.300" (7.62 mm)
- Slot width 0.100" (2.54 mm)
- Choice of three mounting configurations

Description:

Each OPB854 series contains an Infrared Light Emitting Diode (LED) and an NPN silicon phototransistor mounted on opposite sides of a 0.100" (2.54 mm) wide slot in an opaque plastic housing. The OPB854 series has an equivalent aperture of 0.60" (1.52 mm) in diameter because of the lens on the emitting and sensing devices.

The difference between the OPB854A series and OPB854B series are electrical characteristics.

Switching of the phototransistor occurs whenever an opaque object passes through the slot.

Applications:

- Non-contact interruptive object sensing
- Assembly line automation
- Machine automation
- Equipment security
- Machine safety

| Ordering Information | | | | | |
|----------------------|---------------------|------------|--------------------|-------------------------|-----------------------|
| Part Number | LED Peak Wavelength | Sensor | Slot Width / Depth | Aperture Emitter/Sensor | Lead Length / Spacing |
| OPB854A1 | 890 nm | Transistor | 0.100" / 0.250" | None | 0.400" / 0.300" |
| OPB854B1 | | | | | |
| OPB854A2 | | | | | |
| OPB854B2 | | | | | |
| OPB854A3 | | | | | |
| OPB854B3 | | | | | |

General Note

TT Electronics reserves the right to make changes in product specification without notice or liability. All information is subject to TT Electronics' own data and is considered accurate at time of going to print.

TT Electronics | OPTEK Technology
2900 E. Plano Pkwy, Plano, TX 75074 | Ph: +1 972 323 2200
www.ttelectronics.com | sensors@ttelectronics.com

Slotted Optical Switch

OPB854A1, OPB854A2, OPB854A3,
OPB854B1, OPB854B2, OPB854B3



Electrical Specifications

Absolute Maximum Ratings ($T_A=25^\circ\text{C}$ unless otherwise noted)

| | |
|--|------------------|
| Storage & Operating Temperature Range | -40° C to +85° C |
| Lead Soldering Temperature [1/16 inch (1.6mm) from the case for 5 sec. with soldering iron] ⁽¹⁾ | 260° C |

Input Diode

| | |
|---|--------|
| Forward DC Current | 50 mA |
| Peak Forward Current (1 μs pulse width, 300 pps) | 3 A |
| Reverse DC Voltage | 2 V |
| Power Dissipation ⁽²⁾ | 100 mW |

Output Phototransistor

| | |
|----------------------------------|--------|
| Collector-Emitter Voltage | 30 V |
| Emitter-Collector Voltage | 5 V |
| Collector DC Current | 30 mA |
| Power Dissipation ⁽²⁾ | 100 mW |

Electrical Characteristics ($T_A = 25^\circ\text{C}$ unless otherwise noted)

| SYMBOL | PARAMETER | MIN | TYP | MAX | UNITS | TEST CONDITIONS |
|--------|-----------|-----|-----|-----|-------|-----------------|
|--------|-----------|-----|-----|-----|-------|-----------------|

Input Diode (see OP140 for additional information)

| | | | | | | |
|-------|-----------------|---|---|-----|---------------|-----------------------|
| V_F | Forward Voltage | - | - | 1.7 | V | $I_F = 20 \text{ mA}$ |
| I_R | Reverse Current | - | - | 10 | μA | $V_R = 2 \text{ V}$ |

Output Phototransistor (see OP550 for additional information)

| | | | | | | |
|---------------|-------------------------------------|----|---|-----|----|---|
| $V_{(BR)CEO}$ | Collector-Emitter Breakdown Voltage | 30 | - | - | V | $I_C = 1 \text{ mA}$ |
| $V_{(BR)ECO}$ | Emitter-Collector Breakdown Voltage | 5 | - | - | V | $I_E = 100 \mu\text{A}$ |
| I_{CEO} | Collector Dark Current | - | - | 100 | nA | $V_{CE} = 10 \text{ V}, I_F = 0, E_E = 0$ |

Combined

| | | | | | | |
|---------------|--|--------|--------|------------|----|---|
| $V_{CE(SAT)}$ | Collector-Emitter Saturation Voltage OPB854A series OPB854B series | - - | - - | 0.6 0.4 | V | $I_C = 2 \text{ mA}, I_F = 16 \text{ mA}$ $I_C = 250 \mu\text{A}, I_F = 20 \text{ mA}$ |
| $I_{C(ON)}$ | On-State Collector Current OPB854A series OPB854B series | 3 1 | - - | - - | mA | $V_{CE} = 1 \text{ V}, I_F = 16 \text{ mA}$ $V_{CE} = 10 \text{ V}, I_F = 20 \text{ mA}$ |

Notes:

- (1) RMA flux is recommended. Duration can be extended to 10 seconds maximum when flow soldering.
- (2) Derate linearly 1.67 mW/°C above 25 ° C.
- (3) All parameters tested using pulse techniques.
- (4) Lead spacing of 0.220" (5.59 mm) or 0.320" (8.13 mm) is available. Leads are 0.20" sq. (5.1 mm) and 0.425" (10.8 mm) long (minimum).
- (5) Methanol or isopropanol are recommended as cleaning agents. Plastic housing is soluble in chlorinated hydrocarbons and ketones.
- (6) Polarity is denoted by color of housing top (gray or clear LED, black sensor).

General Note

TT Electronics reserves the right to make changes in product specification without notice or liability. All information is subject to TT Electronics' own data and is considered accurate at time of going to print.

TT Electronics | OPTEK Technology
2900 E. Plano Pkwy, Plano, TX 75074 | Ph: +1 972 323 2200
www.ttelectronics.com | sensors@ttelectronics.com

Slotted Optical Switch

OPB854A1, OPB854A2, OPB854A3,
OPB854B1, OPB854B2, OPB854B3

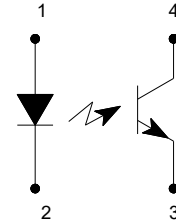
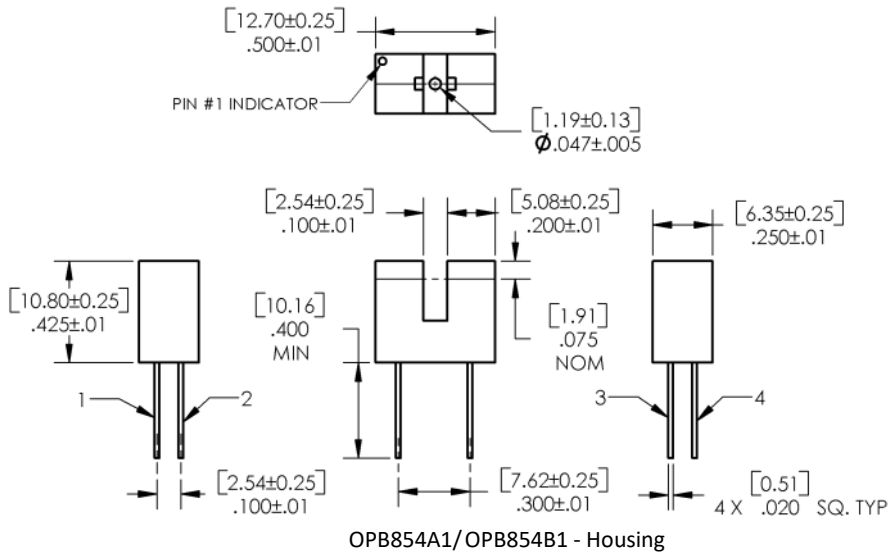

| Pin # | Description |
|-------|-------------|
| 1 | Anode |
| 2 | Cathode |
| 3 | Emitter |
| 4 | Collector |

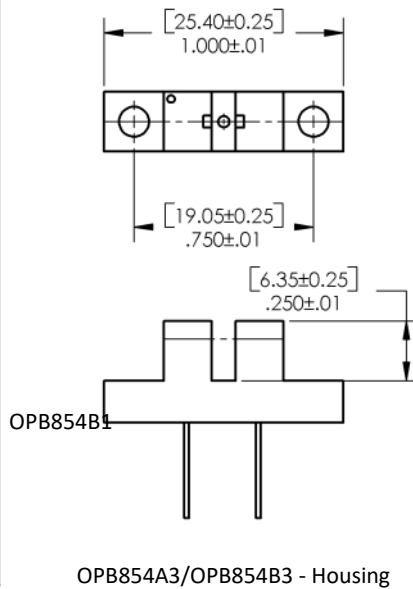
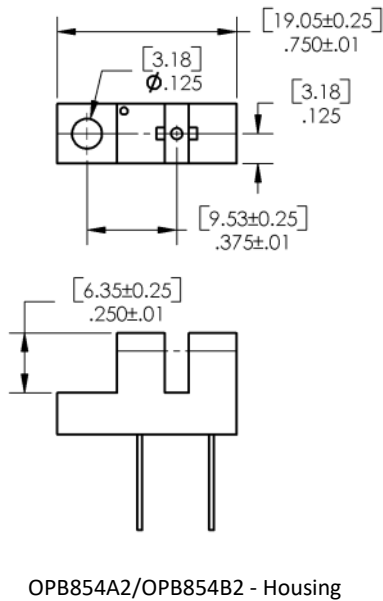

Flag Travel for Graphs on page 4

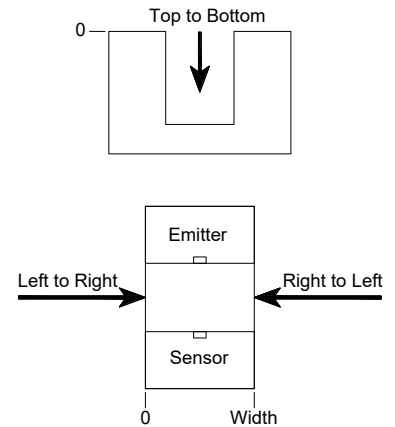

[MILLIMETERS]
DIMENSIONS ARE IN:
INCHES

General Note

TT Electronics reserves the right to make changes in product specification without notice or liability. All information is subject to TT Electronics' own data and is considered accurate at time of going to print.

TT Electronics | OPTEK Technology
2900 E. Plano Pkwy, Plano, TX 75074 | Ph: +1 972 323 2200
www.ttelectronics.com | sensors@ttelectronics.com

Slotted Optical Switch

OPB854A1, OPB854A2, OPB854A3,
OPB854B1, OPB854B2, OPB854B3



Flag Next to Emitter

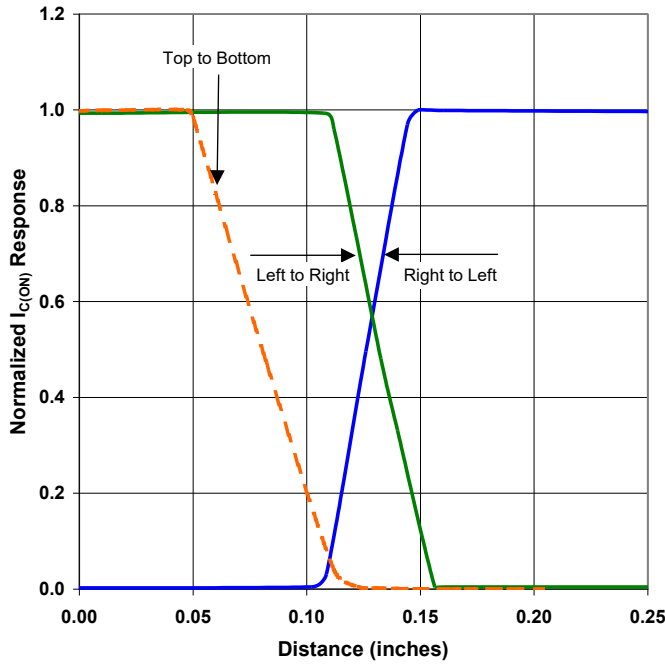

Flag Next to Sensor

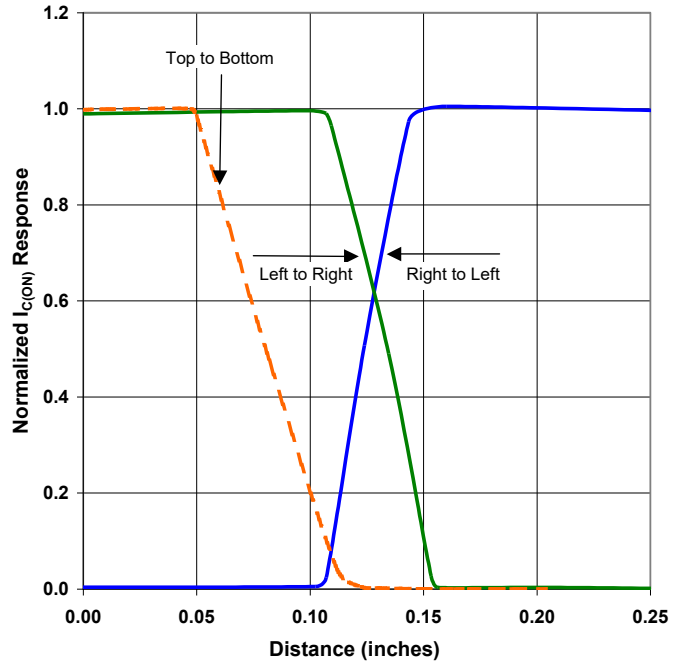

Flag in Middle of Slot

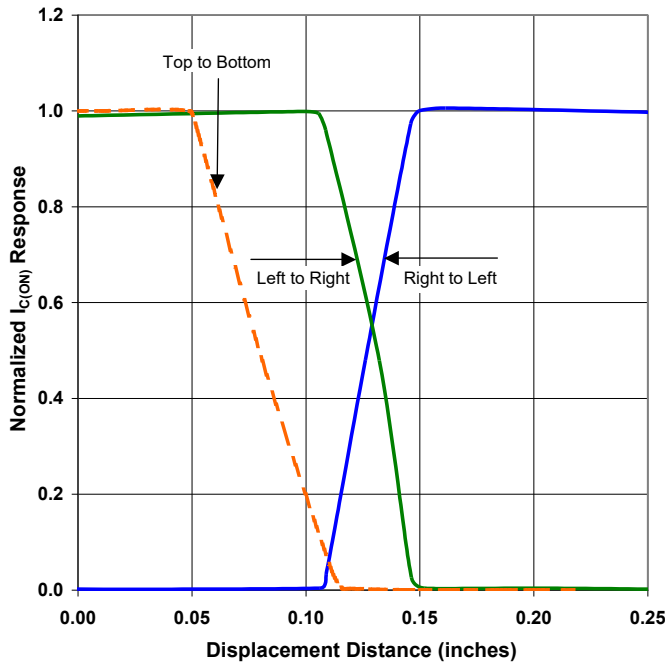

Output Current vs Forward Current vs Temperature

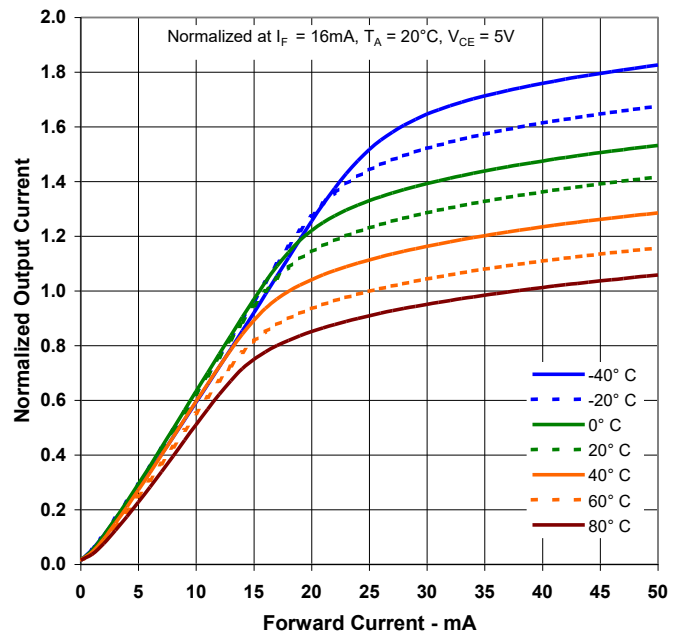

General Note
TT Electronics reserves the right to make changes in product specification without notice or liability. All information is subject to TT Electronics' own data and is considered accurate at time of going to print.

TT Electronics | OPTEK Technology
2900 E. Plano Pkwy, Plano, TX 75074 | Ph: +1 972 323 2200
www.ttelectronics.com | sensors@ttelectronics.com