

ISL95816

4-Phase PWM Controller for VR12.5 CPUs

FN7979  
Rev 0.00  
August 2, 2013

The ISL95816 Pulse Width Modulation (PWM) controller IC provides a complete solution for VR12.5™ compliant microprocessor core power supplies. It provides the control and protection for a Voltage Regulator (VR). The VR can operate in 4-, 3-, 2- or 1-phase configurations. The VR uses a serial control bus to communicate with the CPU and achieve lower cost and smaller board area.

The VR utilizes Intersil's Robust Ripple Regulator R3 Technology™. The R3 modulator has numerous advantages compared to traditional modulators, including faster transient response, variable switching frequency during load transients, and improved light load efficiency due to its ability to automatically change switching frequency.

The ISL95816 has several other key features. It supports either DCR current sensing with a single NTC thermistor for DCR temperature compensation, or more precise resistor current sensing if desired; remote voltage sense; programmable  $V_{BOOT}$  voltage,  $I_{MAX}$ , voltage transition slew rate and switching frequency; adjustable overcurrent protection; and Power-Good signal.

Features

- Serial data bus
- Configurable 4-, 3-, 2- or 1-phase
- R3 Modulator
  - Excellent transient response
  - High light load efficiency
- 0.5% System accuracy over-temperature
- Supports multiple current sensing methods
  - Lossless inductor DCR current sensing
  - Precision resistor current sensing
- Differential remote voltage sensing
- Programmable  $V_{BOOT}$  voltage at start-up
- Resistor programmable  $I_{MAX}$ ,  $V_{BOOT}$ , voltage transition slew rate and switching frequency
- Adaptive body diode conduction time reduction

Applications

- VR12.5 Notebook and Desktop Computers

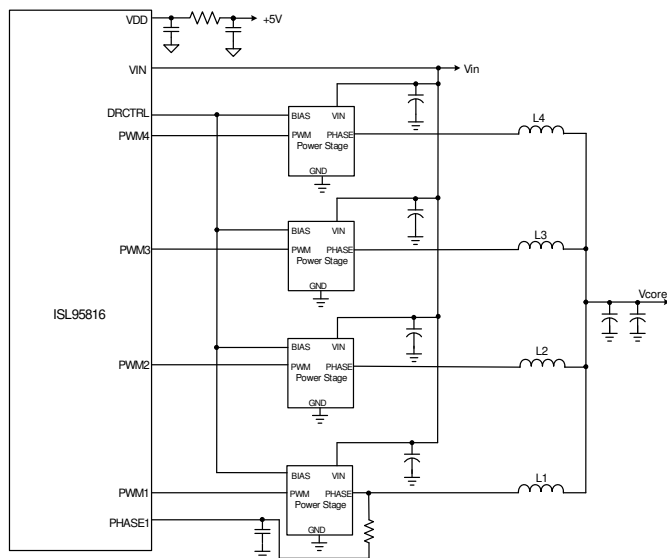

FIGURE 1. SIMPLIFIED APPLICATION CIRCUIT

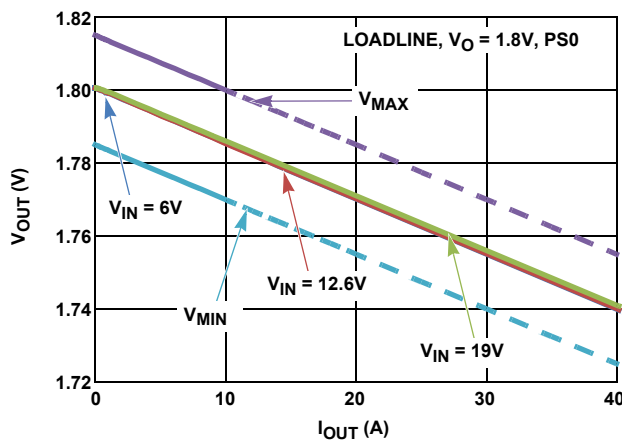

FIGURE 2. LOAD LINE REGULATION

**© Copyright Intersil Americas LLC 2013. All Rights Reserved.**  
**All trademarks and registered trademarks are the property of their respective owners.**

For additional products, see [www.intersil.com/en/products.html](http://www.intersil.com/en/products.html)

---

Intersil products are manufactured, assembled and tested utilizing ISO9001 quality systems as noted in the quality certifications found at [www.intersil.com/en/support/qualandreliability.html](http://www.intersil.com/en/support/qualandreliability.html)

---

*Intersil products are sold by description only. Intersil may modify the circuit design and/or specifications of products at any time without notice, provided that such modification does not, in Intersil's sole judgment, affect the form, fit or function of the product. Accordingly, the reader is cautioned to verify that datasheets are current before placing orders. Information furnished by Intersil is believed to be accurate and reliable. However, no responsibility is assumed by Intersil or its subsidiaries for its use; nor for any infringements of patents or other rights of third parties which may result from its use. No license is granted by implication or otherwise under any patent or patent rights of Intersil or its subsidiaries.*

---

For information regarding Intersil Corporation and its products, see [www.intersil.com](http://www.intersil.com)