

REVISION			
REV.	DESCRIPTION	DATE	APPROVED
A	Changed HDMI/M Mold Design /	03-12-07	DP
	Changed from Crimp Terminal to Solder Terminal		
B	Graphics and Notes Update	01-28-08	DP

THESE DRAWINGS ARE THE PROPERTY OF QUALTEK ELECTRONICS AND NOT TO BE REPRODUCED FOR OR COMMUNICATED TO A THIRD PARTY WITHOUT THE EXPRESS WRITTEN PERMISSION OF AN OFFICER OF QUALTEK ELECTRONICS.

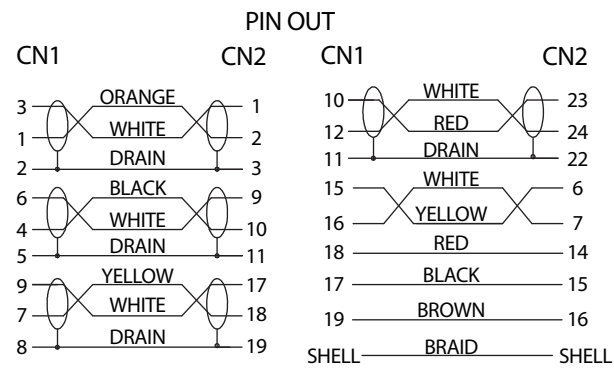
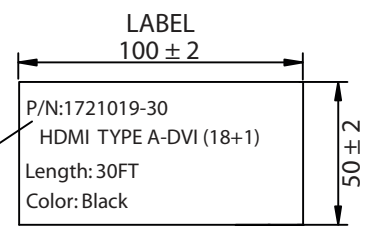
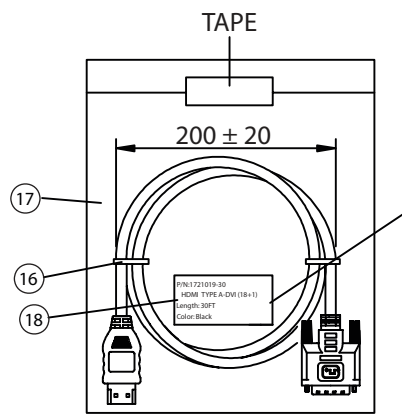
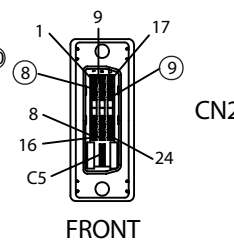
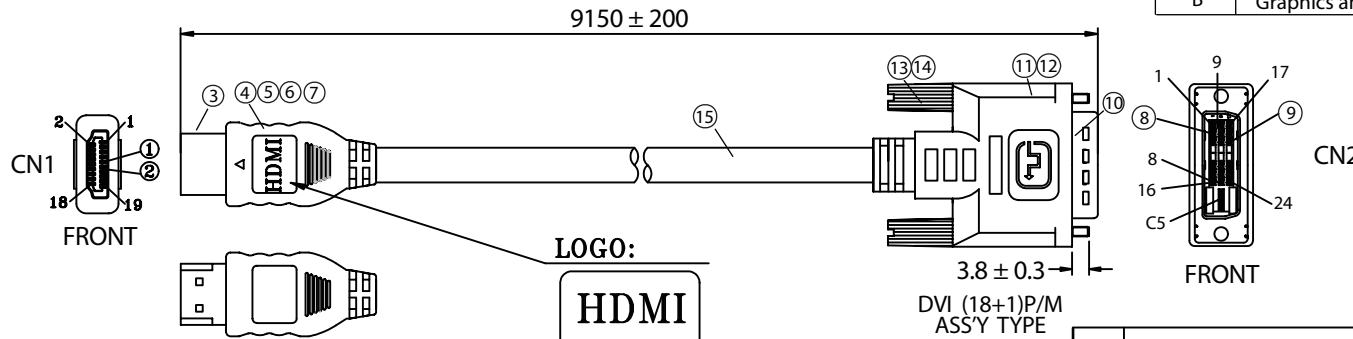

**CONTROLLED**

No.	PARTS NAME	SPECIFICATION STANDARD	QTY	REMARKS
①	HDMI/M - CONTACT	BRASS / GOLD FLASH	19	
②	HDMI/M - INSULATOR	PBT / BLACK	1	
③	HDMI/M - SHELL	STEEL / NICKEL PLATED	1	
④	PCB		1	
⑤	HDMI/M - INNER MOLD	PE NATURAL	1	
⑥	HDMI/M - COPPER FOIL	WIDTH: 20mm	1	
⑦	HDMI/M - OUTER MOLD	60P PVC / COLOR: BLACK	1	
⑧	DVI (18+1)P/M - CONTACT	BRONZE / GOLD FLASH SOLDER TYPE	19	
⑨	DVI (18+1)P/M - INSULATOR	THERMOPLASTIC / BLACK UL94-V0	1	
⑩	DVI (18+1)P/M - SHELL	STEEL NICKEL PLATED	1	
⑪	CAN	STEEL TIN PLATED ID: 8.5mm	1	
⑫	DVI (18+1)P/M - COVER	45P PVC / COLOR: BLACK	1	
⑬	THUMB SCREW	#4-40 2.8x45, NICKEL PLATED	2	
⑭	SCREW-MOLD	35P PVC / COLOR: BLACK	2	
⑮	CABLE	KL03035ABK01A	1	
⑯	MINI TIE	PE / BLACK	2	
⑰	POLYBAG	PE / 0.8x220x250mm	1	
⑱	LABEL	WHITE BOTTOM BLACK WORD	1	

**NOTES:**

- CABLE: UL20276  
 [(26AWGx1P+DW+FOIL)x4+28AWGx3C+28AWGx1P+MYLAR+FOIL+BD]x1  
 OUTER PVC JACKET: BLACK, OD: 8.0 ± 0.2mm, COLOR: BLACK  
 CHARACTER IMPEDENCE: 100 ohm  
 PRINTING: "E166307 AWM STYLE 20276 26AWG 80°C 30V VW-1  
 LOW VOLTAGE COMPUTER CABLE"
- CONNECTORS: HDMI MALE TO DVI (18+1) MALE.
- HOOD: MOLDED TYPE, COLOR: BLACK  
 COPPER FOIL MUST BE SOLDERED 360° AROUND THE CONNECTOR SHELL
- ELECTRICAL TEST:  
 <1>.100% OPEN SHORT & MISS WIRE TEST  
 <2>.INSULATION RESISTANCE: DC400V 10M ohm MIN.  
 <3>.CONDUCTOR RESISTANCE: 3 ohm MAX.
- PACKING: 1PCS/POLYBAG

Dim range (mm)	Tolerance +/- (mm)	Qualtek Electronics Corp. WCT DIVISION		
		Part Number: 1721019-30	RoHS Compliant	
0-1	0.15	Description: HDMI/M - DVI (18+1)P/M		
1-6	0.20		UNIT: mm	REV. B
6-18	0.30			
18-50	0.50			
50-120	0.70	Drawn / Date	Checked / Date	Approved / Date
120-250	0.90	B. Grubb 01-25-07	01-25-07	JJH / 01-25-07
250-500	1.20			