

Amphenol  
FCi

© 2016 AFci

A

B

C

D

A

B

C

D

Cable KITS P/N	10113575-101LF	10113575-102LF
AWG Size	26	28 & 30

Notes:

- This product meets europe union directives and other country regulations as described in GS-47-0004.
- The product is not intended to be exposed to a manufacturing solder process.
- Material:  
Die casting cover: Zn alloy with Cu; Nickel & pure tin plating  
Shroud housing: Black PBT 30% GF.  
Terminal block housing: Black PBT 30% GF.  
Terminal: Copper alloy  
ESD spring: Steel stainless.  
Screw: Steel stainless
- Applicable individual wire insulation  $\varnothing 0.90$  MM max.
- For plating performance level refer drawing #10159408.
- The cable must be flexible to be bent under the line as below draft shown after cable assembled.
- Product specification GS-12-562  
Application specification: GS-20-114  
Packaging specification: GS-14-1292

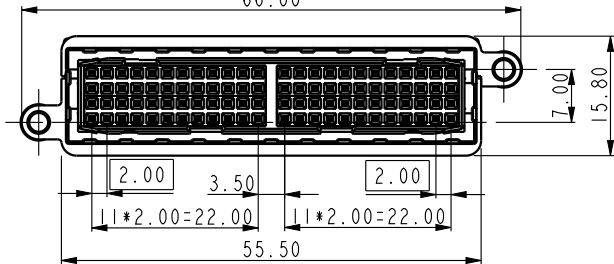
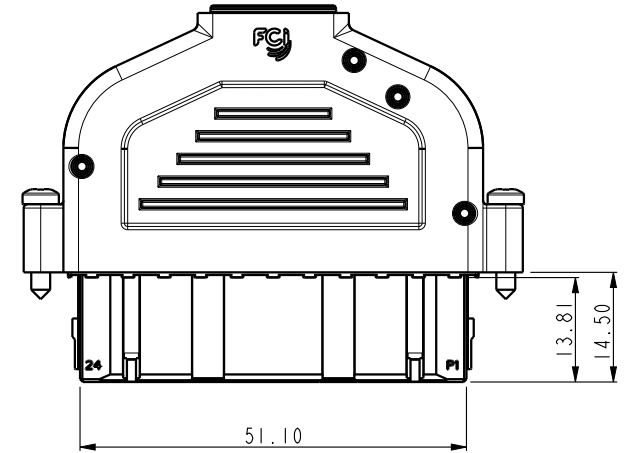
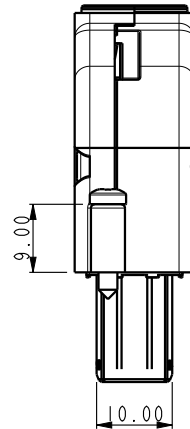
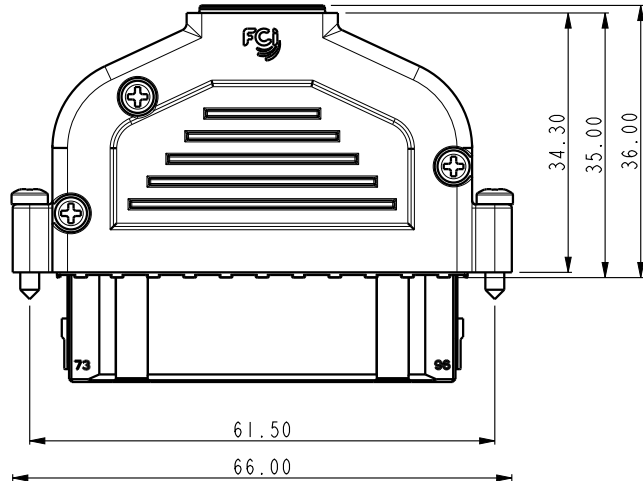
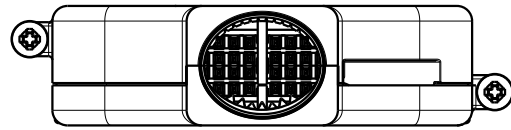

spec ref	*	dr	Junon Huang	2010/03/06	projection	MM	size	A4	scale	1.000
tolerance std	ISO 406 ISO 1101	eng	Narayanan, Aru	2020/10/31		$\longleftrightarrow$	ecn no	ELX-I-38804-1		
TOLERANCES UNLESS OTHERWISE SPECIFIED		chr	-	-			rel level	Released		
surface	linear	appr	Kuriakose, San	2020/11/02	product family		-			
	angular	Amphenol FCi		title		96pos cable connector		vertical type		rev
	0.X			cat. no.		-		Product - Customer Drw		C
	0.XX							10113575		sheet 1 of 2
	0.XXX									
	0°									
	±0.3									
	±0.15									
	±0.050									
	±2°									

BOM OF CABLE KITS

CONNECTOR PART NUMBER	COMPONENT PART DETAILS & (QTY)						
	UPPER COVER(1)	LOWER COVER(1)	SHROUD HOUSING WITH ESD SPRING (1)	TERMINAL BLOCK ASSEMBLY (4)	CABLE CLAMP (1)	SCREW LOCK WITH BOARD CONNECTOR (2)	SCREW TO COVER & CLAMP (4)
10113575-101LF	10113576-001LF	10113577-001LF	10087046-001LF	10087045-001LF	10087042-001LF	10087047-001LF	10089066-001LF
10113575-102LF	10113576-001LF	10113577-001LF	10087046-001LF	10087045-002LF	10087042-001LF	10087047-001LF	10089066-001LF

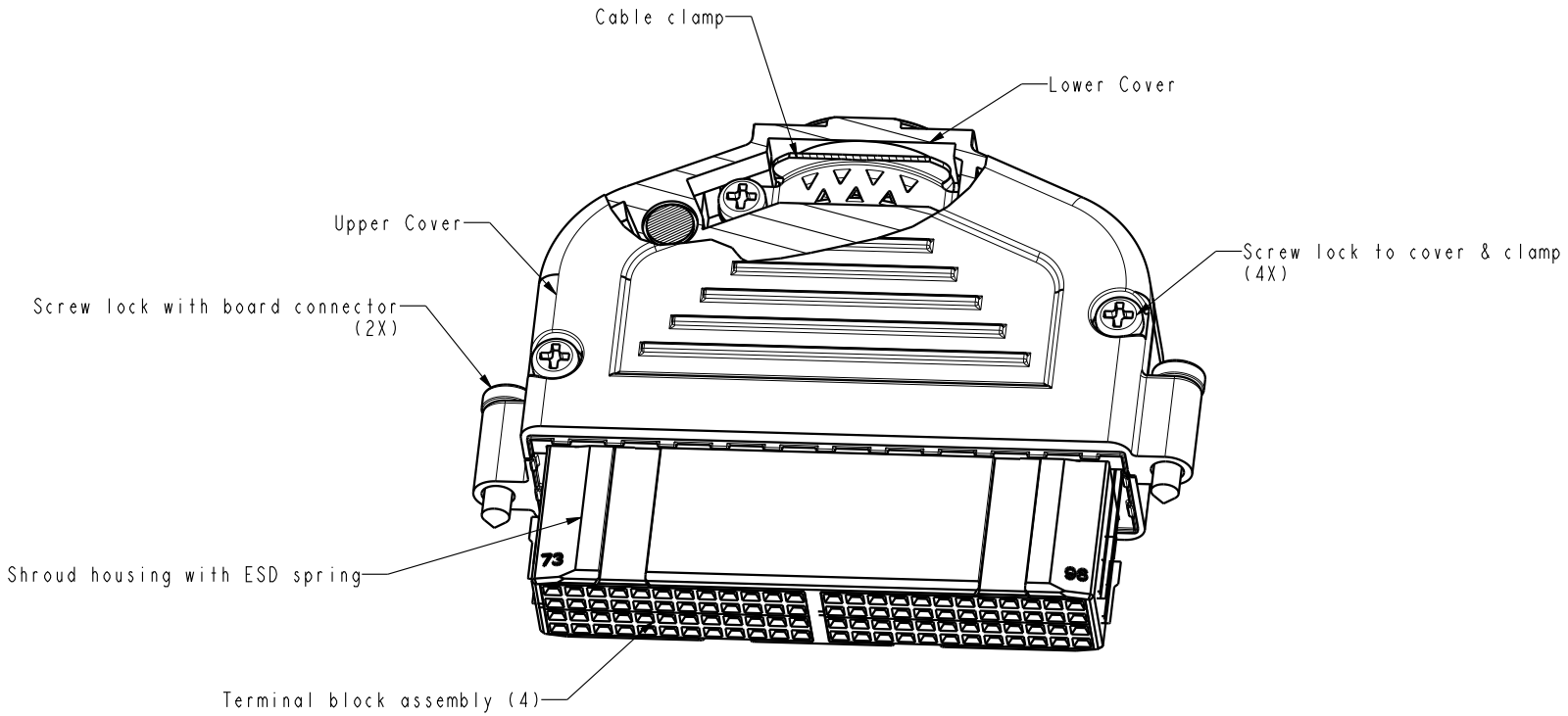

spec ref	*	dr	Junon Huang	2010/03/06	projection	MM	size	A4	scale	1.000			
tolerance std	TOLERANCES UNLESS OTHERWISE SPECIFIED	eng	Narayanan, Aru	2020/10/31		←→	ecn no	ELX-I-38804-1					
ISO 406		chr	-	-			rel level	Released					
ISO 1101		appr	Kuriakose, San	2020/11/02	product family	-							
surface	linear	0.X	±0.3	<b>Amphenol FCi</b>	title	96pos cable connector	dwg no	10113575	rev	C			
ISO 1302	0.XX	±0.15	cat. no.								-	Product - Customer Drw	sheet 2 of 2
	angular	0°											