

NOTES:

- 1. MATERIALS: "G" STYLE
  - 1.1 SHELL, FERRULE  
BRASS PER QQ-B-626  
FINISH: GOLD, OVER  
ELECTROLESS NICKEL  
PER MIL-G-45204, TYP 2, CLASS 1
  - 1.2 INSERT  
PEEK, GLASS FILLED PER  
MIL-P-46183
  - 1.3 CONTACTS  
COPPER ALLOY  
FINISH: GOLD PER MIL-G-45204
  - 1.4 GASKETS  
SILICONE RUBBER PER AMS 3304
  - 1.5 ALTERNATE SHELL MATERIALS  
AND FINISHES:  
"M" STYLE: BRASS, WITH  
ELECTROLESS NICKEL FINISH  
PER AMS-C-26074, CLASS 4, GRADE B  
"A" STYLE: BRASS, WITH GOLD PLATE,  
BLACK CHROMATE  
"K" STYLE: STAINLESS STEEL,  
300 SERIES, WITH PASSIVATION

REVISION HISTORY		
REVISION	DATE	COMMENT
0	02 /10 / 17	INITIAL RELEASE

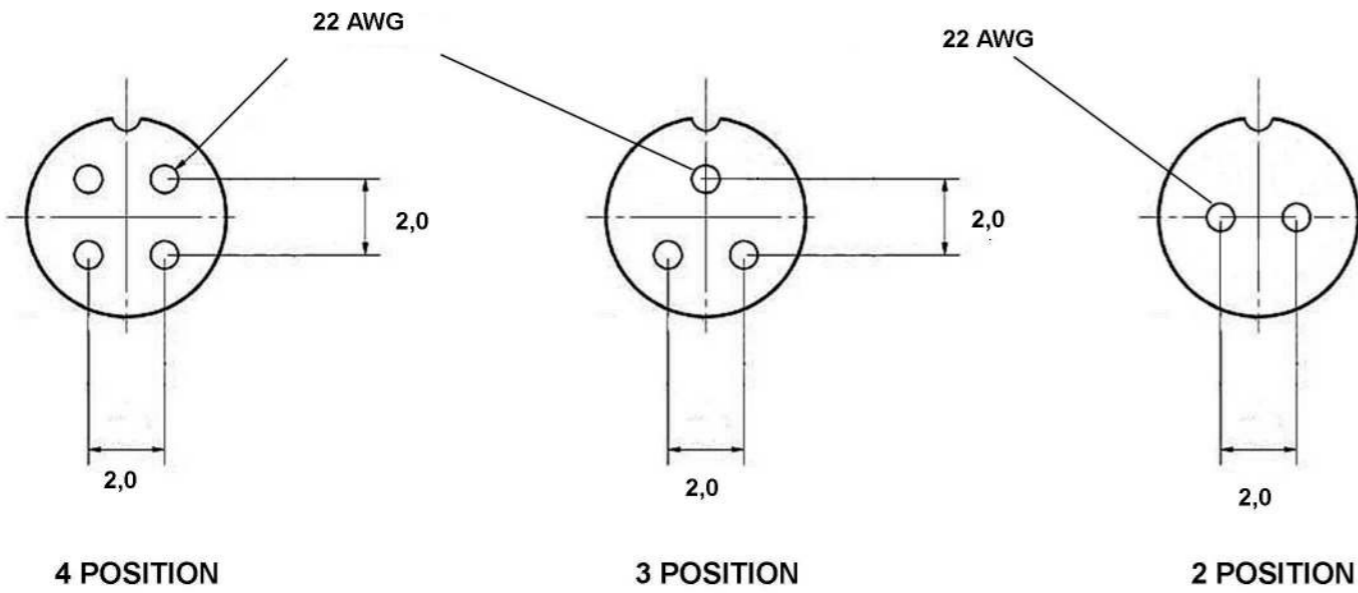
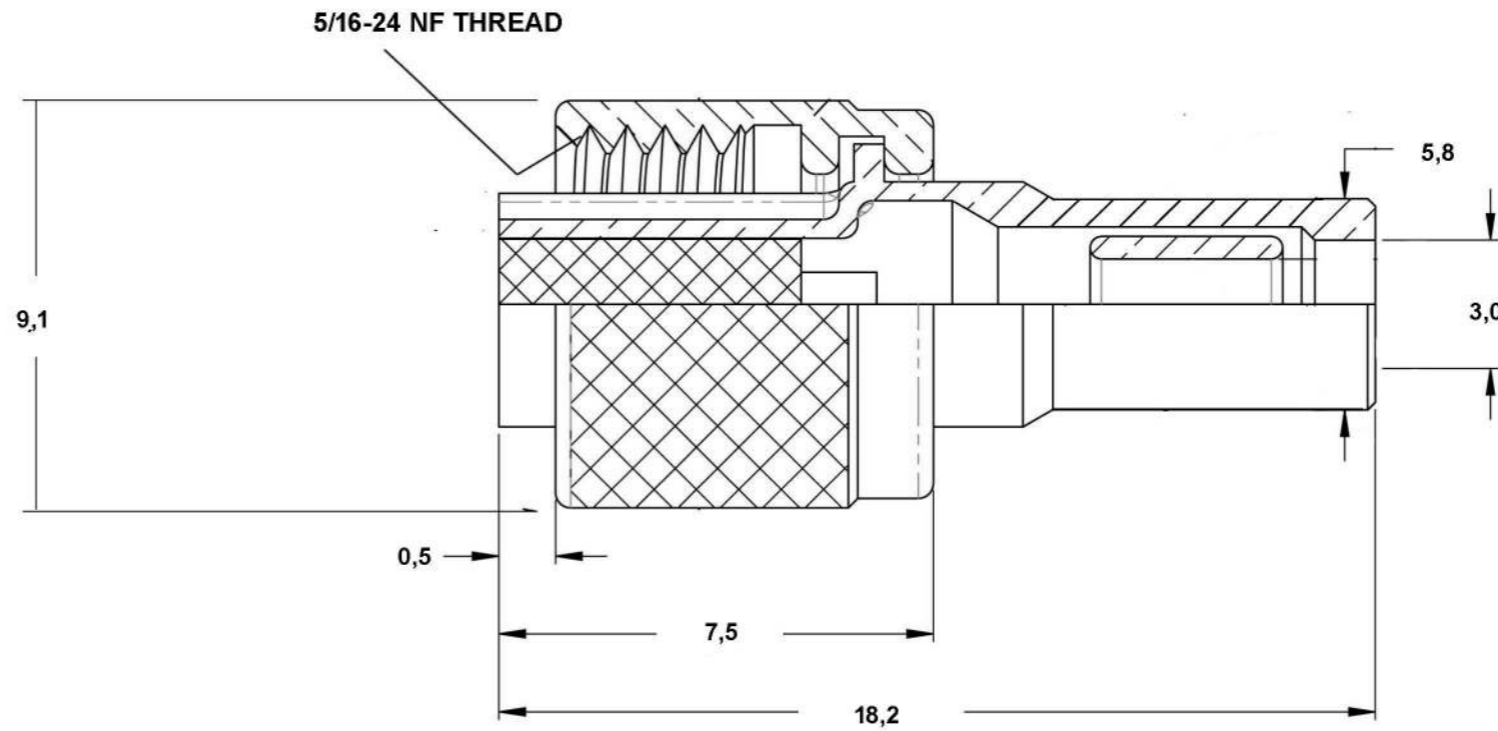

UNLESS OTHERWISE NOTED:  
DIMENSIONS ARE IN MILLIMETERS  
DO NOT SCALE THIS DRAWING

.X DECIMALS ARE ±0.5  
.XX DECIMALS ARE ±0.25  
.XXX DECIMALS ARE ±0.13

ANGLES ARE ±0.5°

DRAWING	SC	MILSPECWEST - MICRO PRODUCTS <b>CAGE CODE: 3HD49</b>	
CHECKED	TS	DESCRIPTION: <b>MICRO HEAVY DUTY PLUG</b>	
Q.A.	KB	DWG. NO.	REVISION: 0
		<b>MSWH-*-B-***</b>	SHEET 1 OF 2

THIS DOCUMENT IS SOLE PROPERTY OF MILSPECWEST AND IS ISSUED IN STRICT CONFIDENCE THAT IT WILL NOT BE REPRODUCED IN ANY WAY OR USED TO SOLICIT BUSINESS OF A COMPETITIVE NATURE. DISTRIBUTION OF THIS DOCUMENT IS PROHIBITED UNLESS WRITTEN CONSENT IS OBTAINED FROM MILSPECWEST. THIS DOCUMENT IS SUITABLE FOR ENGINEERING EVALUATION AND MAY BE USED IN TECHNICAL SPECIFICATIONS.

REVISION HISTORY

REVISION	DATE	COMMENT
0	02/17/2017	

NOTES:

1. MATERIALS: "G" STYLE
  - 1.1 SHELL, FERRULE  
BRASS PER QQ-B-626  
FINISH: GOLD, OVER  
ELECTROLESS NICKEL  
PER MIL-G-45204, TYP 2, CLASS 1
  - 1.2 INSERT  
PEEK, GLASS FILLED PER  
MIL-P-46183
  - 1.3 CONTACTS  
COPPER ALLOY  
FINISH: GOLD PER MIL-G-45204
  - 1.4 GASKETS  
SILICONE RUBBER PER AMS 3304
  - 1.5 ALTERNATE SHELL MATERIALS  
AND FINISHES:  
"M" STYLE: BRASS, WITH  
ELECTROLESS NICKEL FINISH  
PER AMS-C-26074, CLASS 4, GRADE B  
"A" STYLE: BRASS, WITH GOLD PLATE,  
BLACK CHROMATE  
"K" STYLE: STAINLESS STEEL,  
300 SERIES, WITH PASSIVATION

**SPECIFICATIONS:**

**ELECTRICAL:**

ELECTRICAL RESISTANCE: 10,000 M OHMS PER MIL-C-22557  
 RATED WORKING VOLTAGE: 400V @ SEA LEVEL  
 DIELECTRIC WITHSTANDING: 1,000 V @ SEA LEVEL PER MIL-C-22557  
 CONTACT VOLTAGE DROP: 4 mV @ 1 AMP PER MIL-C-22557  
 CONTACT RESISTANCE: 4 MOHM @ 1 AMP PER MIL-C-22557  
 CONTACT CURRENT RATING: 3 AMP

**ENVIRONMENTAL:**

VIBRATION: MIL STD 202A METHOD 204 TEST COND B (15G's)  
 NO DISCONTINUITY IN EXCESS OF 1 MICROSECOND  
 SHOCK: MIL STD 202 METHOD 202, 300 G's NO EVIDENCE OF DAMAGE  
 TEMPERATURE CYCLING: MIL STD 202 METHOD 102, CONDITION C  
 CORROSION (SALT SPRAY): MIL STD 202 METHOD 10, COND B 5% SALT SOLUTION  
 MOISTURE RESISTANCE: MIL STD 202C METHOD 106B, OMITTING STEO 7B  
 AND HIGH HUMIDITY TESTS

**MECHANICAL:**

CONTACTS: CONTACTS ARE CONTRAINED IN BOTH DIRECTIONS  
 ENGAGING FORCE: 0.8N PER CONTACT  
 COUPLING RETENTION TORQUE: 60 Nmm  
 CONTACT DURABILITY: 5000 CYCLES WITHH CONTACT RESISTANCE  
 WITHIN MIN MIL-C-22557  
 CABLE RETENTION: SEPARATION FORCE EQUAL TO BREAKING STRENGTH  
 OF SHIELD OF THE CABLE PER MIL-C-22557

PART NUMBER BREAKDOWN

**MSWH - G - B - 04 S**

- P = PIN
- S = SOCKET
- NUMBER OF CONTACTS  
02  
03  
04
- SHELL SIZE (SEE TABLE 2)
- BODY STYLE  
B = PLUG  
R = IN LINE RECEPTACLE  
C = STRAIGHT PCB MOUNT  
D = FRONT PANEL JAM NUT MOUNT  
E = FRONT PANEL SOLDER MOUNT  
F = RIGHT ANGLE PCB MOUNT
- FINISH AND MATERIAL  
G = BRASS WITH GOLD OVER ELEC NICKEL  
M = BRASS WITH ELECTROLESS NICKEL  
A = BRASS WITH BLACK ANODIZE  
K = STAINLESS STEEL WITH PASSIVATION
- BASIC PART NUMBER

UNLESS OTHERWISE NOTED:  
 DIMENSIONS ARE IN MILLIMETERS  
 DO NOT SCALE THIS DRAWING

.X DECIMALS ARE ±0.5  
 .XX DECIMALS ARE ±0.25  
 .XXX DECIMALS ARE ±0.13

ANGLES ARE ±0.5°

THIS DOCUMENT IS SOLE PROPERTY OF MILSPECWEST AND IS ISSUED IN STRICT CONFIDENCE THAT IT WILL NOT BE REPRODUCED IN ANY WAY OR USED TO SOLICIT BUSINESS OF A COMPETITIVE NATURE. DISTRIBUTION OF THIS DOCUMENT IS PROHIBITED UNLESS WRITTEN CONSENT IS OBTAINED FROM MILSPECWEST. THIS DOCUMENT IS SUITABLE FOR ENGINEERING EVALUATION AND MAY BE USED IN TECHNICAL SPECIFICATIONS.

DRAWING	SC	MILSPECWEST - MICRO PRODUCTS <b>CAGE CODE: 3HD49</b>	
CHECKED	TS	DESCRIPTION: <b>MICRO HEAVY DUTY PLUG</b>	
Q.A.	KB	DWG. NO. <b>MSWH-*-B-***</b>	REVISION: 0
			SHEET 2 OF 2