

REVISIONS				
P	LTR	DESCRIPTION	DATE	OWN APVD
A		ECO-18-017212	30NOV2018	FL HL

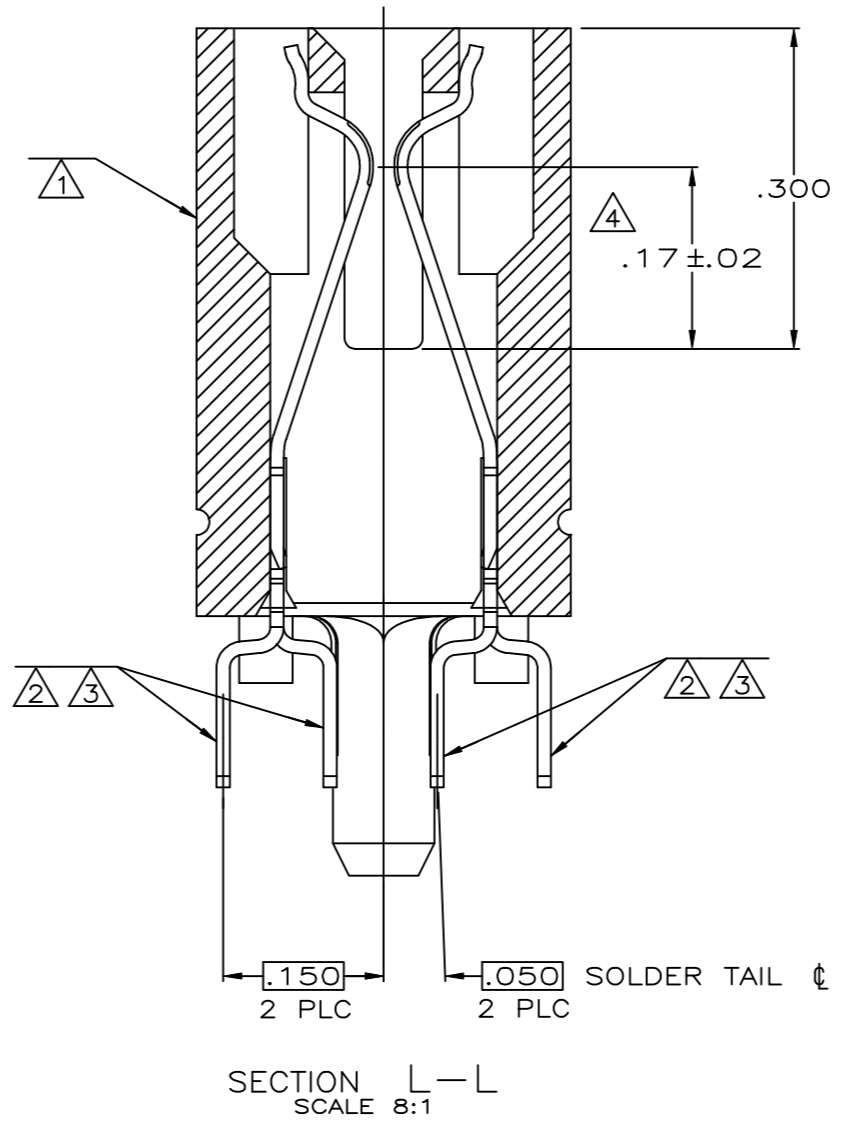

- ① HOUSING: HIGH TEMPERATURE THERMOPLASTIC. COLOR: BROWN.
- ② CONTACT: PHOSPHOR BRONZE.
- ③ CONTACT FINISH: .000100 MIN NICKEL ALL OVER.  
.000030 MIN GOLD OVER NICKEL IN CONTACT AREA.  
.000100 MIN MATTE TIN OVER NICKEL ON SOLDER TAILS.
- ④ DISTANCE FROM CONTACT POINT TO BOTTOM OF CARD SLOT.
- ⑤ AMP PART NUMBER, DATE CODE AND CSA LOGO MARKED IN APPROXIMATE AREA SHOWN.

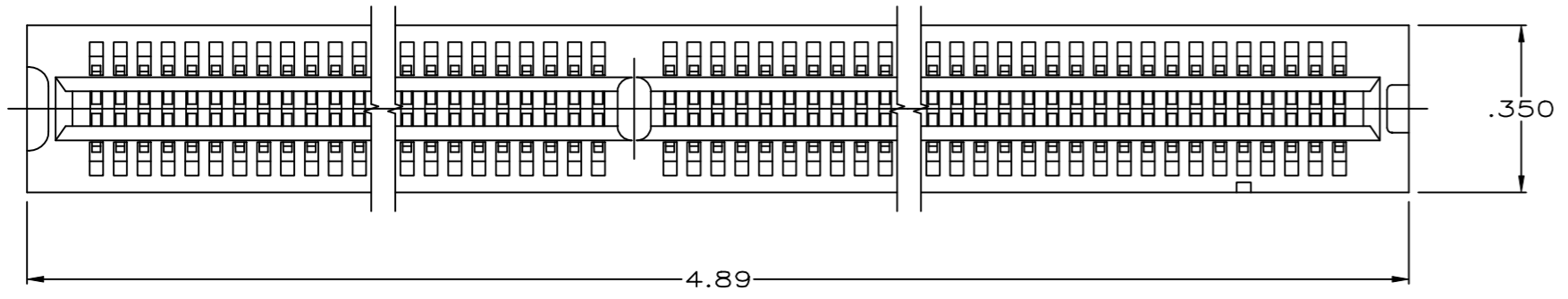
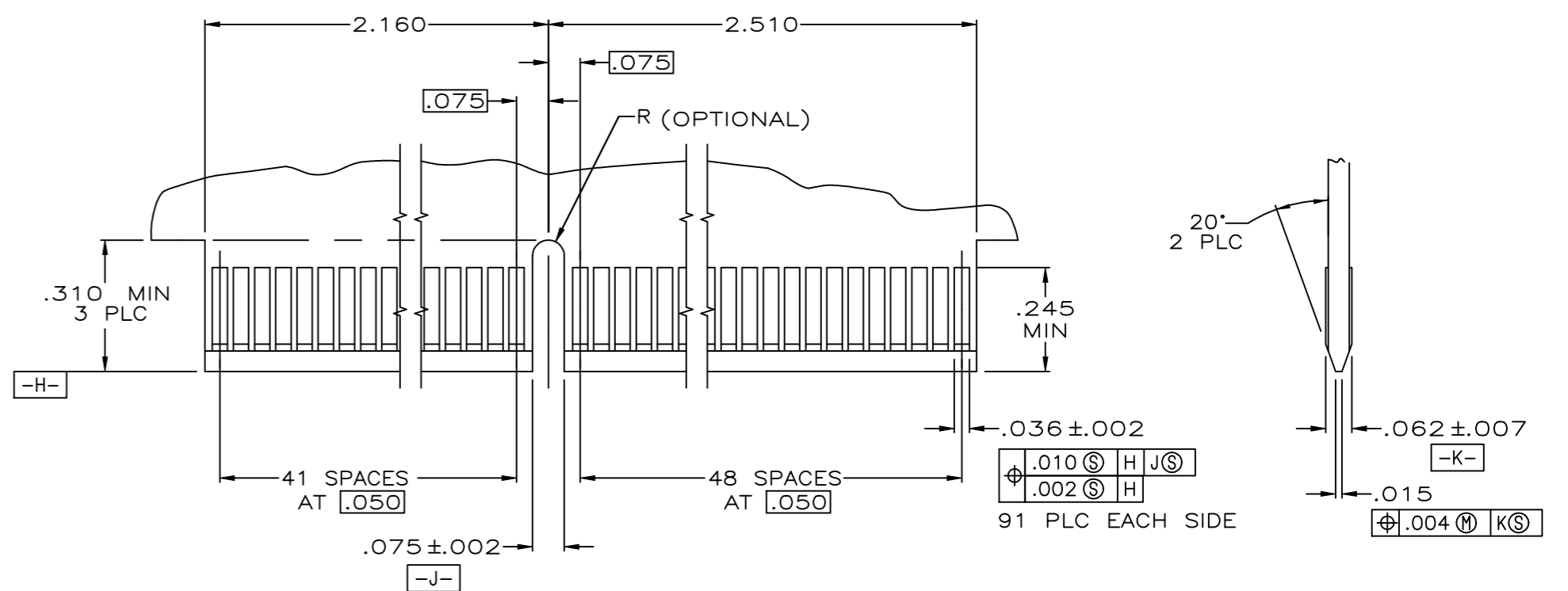
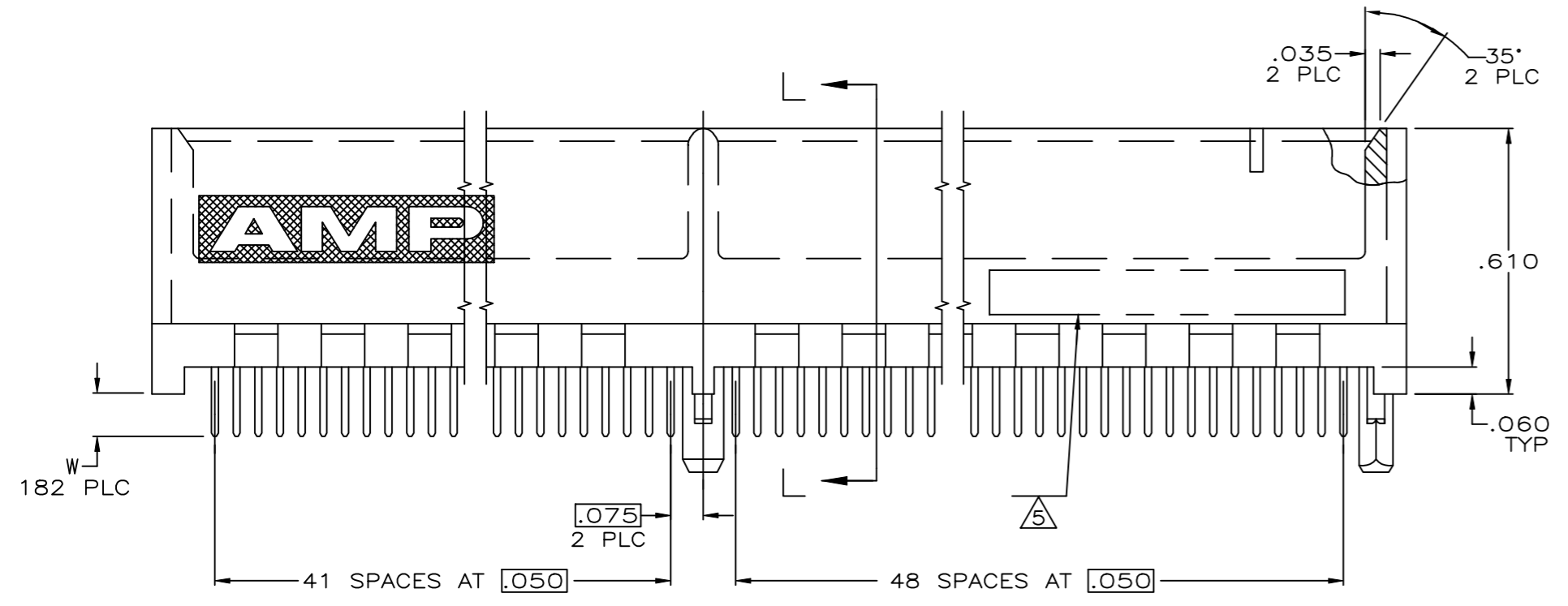

RECOMMENDED MATING BOARD EDGE CONFIGURATION

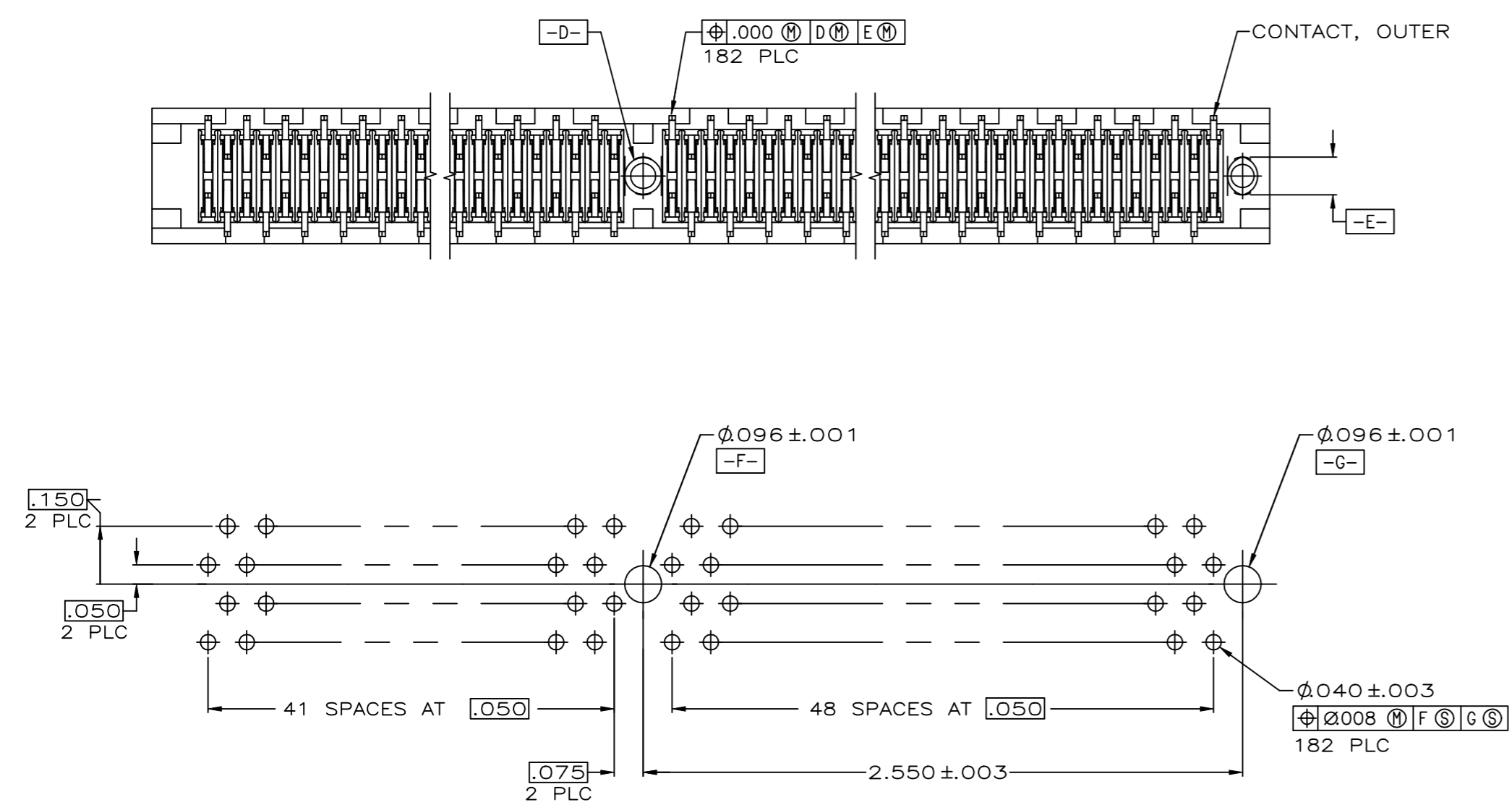

RECOMMENDED CONNECTOR MOUNTING HOLE PATTERN  
(CONNECTOR SIDE SHOWN)

.14	5650092-2
.10	5650092-1
W	PART NUMBER

THIS DRAWING IS A CONTROLLED DOCUMENT.		OWN: AL FRANTUM 24 JUN 05	TE Connectivity CONNECTOR ASSEMBLY, 91 DUAL POSITION, .050 SERIES,			
DIMENSIONS: INCHES		CHK: AL FRANTUM 24 JUN 05				
DIMENSIONS: INCHES 0 PLC ± - 1 PLC ± .01 2 PLC ± .01 3 PLC ± .005 4 PLC ± - ANGLES ± °		APVD: -	PRODUCT SPEC: 108-14034 APPLICATION SPEC: 114-26012 WEIGHT: 0.000000			
MATERIAL: ① ②		FINISH: ③	SIZE: A1	CAGE CODE: 00779	DRAWING NO: C=5650092	RESTRICTED TO: -
CUSTOMER DRAWING			SCALE: 4:1	SHEET: 1 OF 1	REV: A	