

# MC10136

## Universal Hexadecimal Counter

The MC10136 is a high speed synchronous counter that can count up, count down, preset, or stop count at frequencies exceeding 100 MHz. The flexibility of this device allows the designer to use one basic counter for most applications, and the synchronous count feature makes the MC10136 suitable for either computers or instrumentation.

Three control lines (S1, S2, and  $\overline{C_{in}}$ ) determine the operation mode of the counter. Lines S1 and S2 determine one of four operations; preset (program), increment (count up), decrement (count down), or hold (stop count). Note that in the preset mode a clock pulse is necessary to load the counter, and the information present on the data inputs (D0, D1, D2, and D3) will be entered into the counter.  $\overline{C_{out}}$  goes low on the terminal count, or when the counter is being preset.

This device is not designed for use with gated clocks. Control is via S1 and S2.

- $P_D = 625$  mW typ/pkg (No Load)
- $f_{count} = 150$  MHz typ
- $t_{pd} = 3.3$  ns typ (C-Q)
- 7.0 ns typ (C- $\overline{C_{out}}$ )
- 5.0 ns typ ( $\overline{C_{in}}$ - $\overline{C_{out}}$ )

### DIP PIN ASSIGNMENT

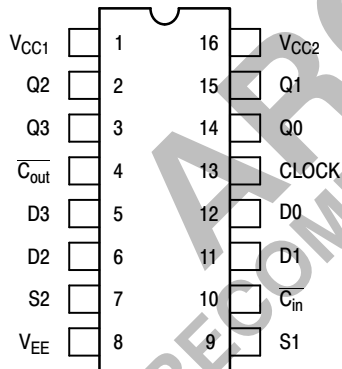

Pin assignment is for Dual-in-Line Package.

For PLCC pin assignment, see the Pin Conversion Tables on page 18 of the ON Semiconductor MECL Data Book (DL122/D).

### FUNCTION TABLE

$\overline{C_{in}}$	S1	S2	Operating Mode
X	L	L	Preset (Program)
L	L	H	Increment (Count Up)
H	L	H	Hold Count
L	H	L	Decrement (Count Down)
H	H	L	Hold Count
X	H	H	Hold (Stop Count)



ON Semiconductor

<http://onsemi.com>

### MARKING DIAGRAMS

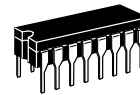

CDIP-16  
L SUFFIX  
CASE 620



PDIP-16  
P SUFFIX  
CASE 648

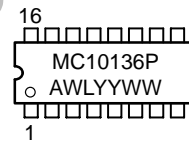

PLCC-20  
FN SUFFIX  
CASE 775

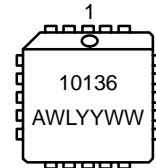

A = Assembly Location  
WL = Wafer Lot  
YY = Year  
WW = Work Week

### ORDERING INFORMATION

Device	Package	Shipping
MC10136L	CDIP-16	25 Units / Rail
MC10136P	PDIP-16	25 Units / Rail
MC10136FN	PLCC-20	46 Units / Rail

# MC10136

## LOGIC DIAGRAM

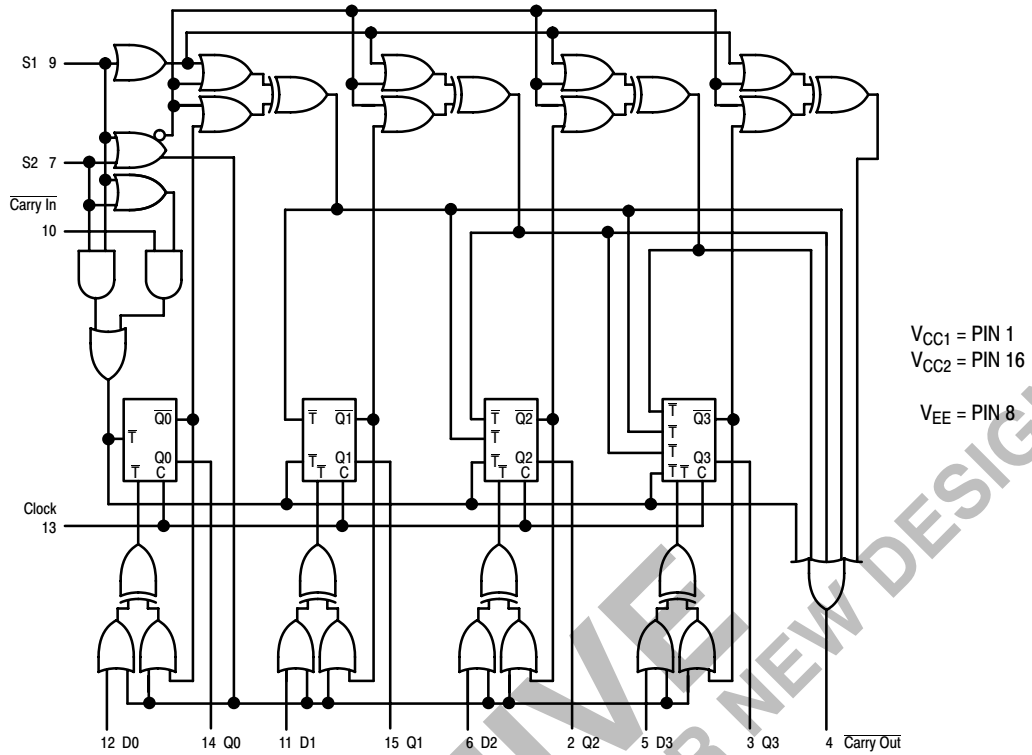

NOTE: Flip-flops will toggle when all  $\bar{T}$  inputs are low.

SEQUENTIAL TRUTH TABLE\*

INPUTS							OUTPUTS					
S1	S2	D0	D1	D2	D3	Carry In	Clock **	Q0	Q1	Q2	Q3	Carry Out
L	L	L	L	H	H	X	H	L	L	H	H	L
L	H	X	X	X	X	L	H	H	L	H	H	H
L	H	X	X	X	X	L	H	L	H	H	H	H
L	H	X	X	X	X	L	H	H	H	H	H	L
L	H	X	X	X	X	H	L	H	H	H	H	H
L	H	X	X	X	X	H	H	H	H	H	H	H
L	H	X	X	X	X	X	H	H	H	H	H	H
L	L	H	H	L	L	X	H	H	H	L	L	L
H	L	X	X	X	X	L	H	L	H	L	L	H
H	L	X	X	X	X	L	H	H	L	L	L	H
H	L	X	X	X	X	L	H	L	L	L	L	L
H	L	X	X	X	X	L	H	H	H	H	H	H

\* Truth table shows logic states assuming inputs vary in sequence shown from top to bottom.

\*\* A clock H is defined as a clock input transition from a low to a high logic level.

# MC10136

## ELECTRICAL CHARACTERISTICS

Characteristic	Symbol	Pin Under Test	Test Limits						Unit		
			-30°C		+25°C			+85°C			
			Min	Max	Min	Typ	Max	Min		Max	
Power Supply Drain Current	$I_E$	8		138		100	125		138	mAdc	
Input Current	$I_{inH}$	5,6,11,12		350			220		220	$\mu$ Adc	
		7 9,10 13		425 390 460			265 245 290		265 245 290		
	$I_{inL}$	All	0.5		0.5			0.3		$\mu$ Adc	
Output Voltage	Logic 1	$V_{OH}$	14 (2.)	-1.060	-0.890	-0.960		-0.810	-0.890	-0.700	Vdc
Output Voltage	Logic 0	$V_{OL}$	14 (2.)	-1.890	-1.675	-1.850		-1.650	-1.825	-1.615	Vdc
Threshold Voltage	Logic 1	$V_{OHA}$	14 (2.)	-1.080		-0.980			-0.910		Vdc
Threshold Voltage	Logic 0	$V_{OLA}$	14 (2.)		-1.655			-1.630		-1.595	Vdc
Switching Times (50 $\Omega$ Load)										ns	
Propagation Delay	Clock Input	$t_{13+14+}$	14	0.8	4.8	1.0	3.3	4.5	1.4	5.0	
		$t_{13+14-}$	14	0.8	4.8	1.0	3.3	4.5	1.4	5.0	
		$t_{13+4+}$	4	2.0	10.9	2.5	7.0	10.5	2.4	11.5	
		$t_{13+4-}$	4	2.0	10.9	2.5	7.0	10.5	2.4	11.5	
Carry In to Carry Out		$t_{10-4-}$	4 (3.)	1.6	7.4	1.6	5.0	6.9	1.9	7.5	
		$t_{10+4+}$	4	1.6	7.4	1.6	5.0	6.9	1.9	7.5	
Setup Time	Data Inputs	$t_{12+13+}$	14	3.5		3.5			3.5		
		$t_{12-13+}$	14	3.5		3.5			3.5		
	Select Inputs	$t_{9+13+}$	14	6.0		6.0			6.0		
		$t_{7+13+}$	14	6.0		6.0			6.0		
Carry In Input		$t_{10-13+}$	14	2.5		2.5			3.0		
		$t_{10+13+}$	14	1.5		1.5			1.5		
Hold Time	Data Inputs	$t_{13+12+}$	14	0		0			0		
		$t_{13+12-}$	14	0		0			0		
	Select Inputs	$t_{13+9+}$	14	-1.0		-1.0			-1.0		
		$t_{13+7+}$	14	-1.0		-1.0			-1.0		
Carry In Input		$t_{13+10-}$	14	0		0			0		
		$t_{13+10+}$	14	0		0			0		
Counting Frequency		$f_{countup}$	14	125		125	150		125		MHz
		$f_{countdown}$	14	125		125	150		125		
Rise Time (20 to 80%)		$t_{4+}$	4	0.9	3.3	1.1	2.0	3.3	1.1	3.5	ns
		$t_{14+}$	14	0.9	3.3	1.1	2.0	3.3	1.1	3.5	
Fall Time (20 to 80%)		$t_{4-}$	4	0.9	3.3	1.1	2.0	3.3	1.1	3.5	
		$t_{14-}$	14	0.9	3.3	1.1	2.0	3.3	1.1	3.5	

1. Individually test each input; apply  $V_{ILmin}$  to pin under test.

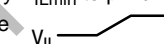
2. Measure output after clock pulse   $V_{IH}$  appears at clock input (Pin 13).

3. Before test set all Q outputs to a logic high.

4. To preserve reliable performance, the MC10136 (plastic packaged device only) is to be operated in ambient temperatures above 70°C only when 500lfpm blown air or equivalent heat sinking is provided.

# MC10136

## ELECTRICAL CHARACTERISTICS (continued)

			TEST VOLTAGE VALUES (Volts)						
			V <sub>IHmax</sub>	V <sub>ILmin</sub>	V <sub>IHAmin</sub>	V <sub>ILAmax</sub>	V <sub>EE</sub>		
@ Test Temperature									
-30°C			-0.890	-1.890	-1.205	-1.500	-5.2		
+25°C			-0.810	-1.850	-1.105	-1.475	-5.2		
+85°C			-0.700	-1.825	-1.035	-1.440	-5.2		
Characteristic	Symbol	Pin Under Test	TEST VOLTAGE APPLIED TO PINS LISTED BELOW					(V <sub>CC</sub> ) Gnd	
			V <sub>IHmax</sub>	V <sub>ILmin</sub>	V <sub>IHAmin</sub>	V <sub>ILAmax</sub>	V <sub>EE</sub>		
Power Supply Drain Current	I <sub>E</sub>	8					8	1, 16	
Input Current	I <sub>inH</sub>	5,6,11,12	5,6,11,12				8	1, 16	
		7	7			8	1, 16		
		9,10	9,10			8	1, 16		
		13	13			8	1, 16		
	I <sub>inL</sub>	All		Note 1.			8	1, 16	
Output Voltage	Logic 1	V <sub>OH</sub>	14 (2.)	12	7, 9		8	1, 16	
Output Voltage	Logic 0	V <sub>OL</sub>	14 (2.)		7, 9		8	1, 16	
Threshold Voltage	Logic 1	V <sub>OHA</sub>	14 (2.)		7, 9	12	8	1, 16	
Threshold Voltage	Logic 0	V <sub>OLA</sub>	14 (2.)		7, 9	12	8	1, 16	
Switching Times (50Ω Load)				<b>+1.11V</b>	<b>+0.31V</b>	<b>Pulse In</b>	<b>Pulse Out</b>	<b>-3.2 V</b>	<b>+2.0 V</b>
Propagation Delay	Clock Input	t <sub>13+14+</sub>	14	12		13	14	8	1, 16
		t <sub>13+14-</sub>	14			13	14	8	1, 16
		t <sub>13+4+</sub>	4	7		13	4	8	1, 16
		t <sub>13+4-</sub>	4	7		13	4	8	1, 16
Carry In to Carry Out		t <sub>10-4-</sub>	4 (3.)	7	13	10	4	8	1, 16
		t <sub>10+4+</sub>	4	7	13	10	4	8	1, 16
Setup Time	Data Inputs	t <sub>12+13+</sub>	14		7, 9	12, 13	14	8	1, 16
		t <sub>12-13+</sub>	14		7, 9	12, 13	14	8	1, 16
	Select Inputs	t <sub>9+13+</sub>	14			9, 13	14	8	1, 16
		t <sub>7+13+</sub>	14			7, 13	14	8	1, 16
Carry In Inputs		t <sub>10-13+</sub>	14	7	9	10, 13	14	8	1, 16
		t <sub>10+13+</sub>	14	7	9	10, 13	14	8	1, 16
Hold Time	Data Inputs	t <sub>13+12+</sub>	14		7, 9	12, 13	14	8	1, 16
		t <sub>13+12-</sub>	14		7, 9	12, 13	14	8	1, 16
	Select Inputs	t <sub>13+9+</sub>	14			9, 13	14	8	1, 16
		t <sub>13+7+</sub>	14			7, 13	14	8	1, 16
Carry In Inputs		t <sub>13+10-</sub>	14	7	9	10, 13	14	8	1, 16
		t <sub>13+10+</sub>	14	7		10, 13	14	8	1, 16
Counting Frequency		f <sub>countup</sub>	14	7		13	14	8	1, 16
		f <sub>countdown</sub>	14	9		13	14	8	1, 16
Rise Time (20 to 80%)		t <sub>4+</sub>	4	7		13	4	8	1, 16
		t <sub>14+</sub>	14	7		13	14	8	1, 16
Fall Time (20 to 80%)		t <sub>4-</sub>	4	7		13	4	8	1, 16
		t <sub>14-</sub>	14	7		13	14	8	1, 16

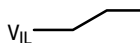
1. Individually test each input; apply V<sub>ILmin</sub> to pin under test.
2. Measure output after clock pulse  V<sub>IH</sub> appears at clock input (Pin 13).
3. Before test set all Q outputs to a logic high.
4. To preserve reliable performance, the MC10136 (plastic packaged device only) is to be operated in ambient temperatures above 70°C only when 500fpm blown air or equivalent heat sinking is provided.

Each MECL 10,000 series circuit has been designed to meet the dc specifications shown in the test table, after thermal equilibrium has been established. The circuit is in a test socket or mounted on a printed circuit board and transverse air flow greater than 500 linear fpm is maintained. Outputs are terminated through a 50-ohm resistor to -2.0 volts. Test procedures are shown for only one gate. The other gates are tested in the same manner.

# MC10136

## SWITCHING TIME TEST CIRCUIT AND WAVEFORMS @ 25°C

**NOTE:**

$t_{setup}$  is the minimum time before the positive transition of the clock pulse (C) that information must be present at the input D or S.

$t_{hold}$  is the minimum time after the positive transition of the clock pulse (C) that information must remain unchanged at the input D or S.

**INPUT PULSE**  
 $T_+ = T_- = 2.0 \pm 0.2 \text{ NS}$   
 (20 TO 80%)

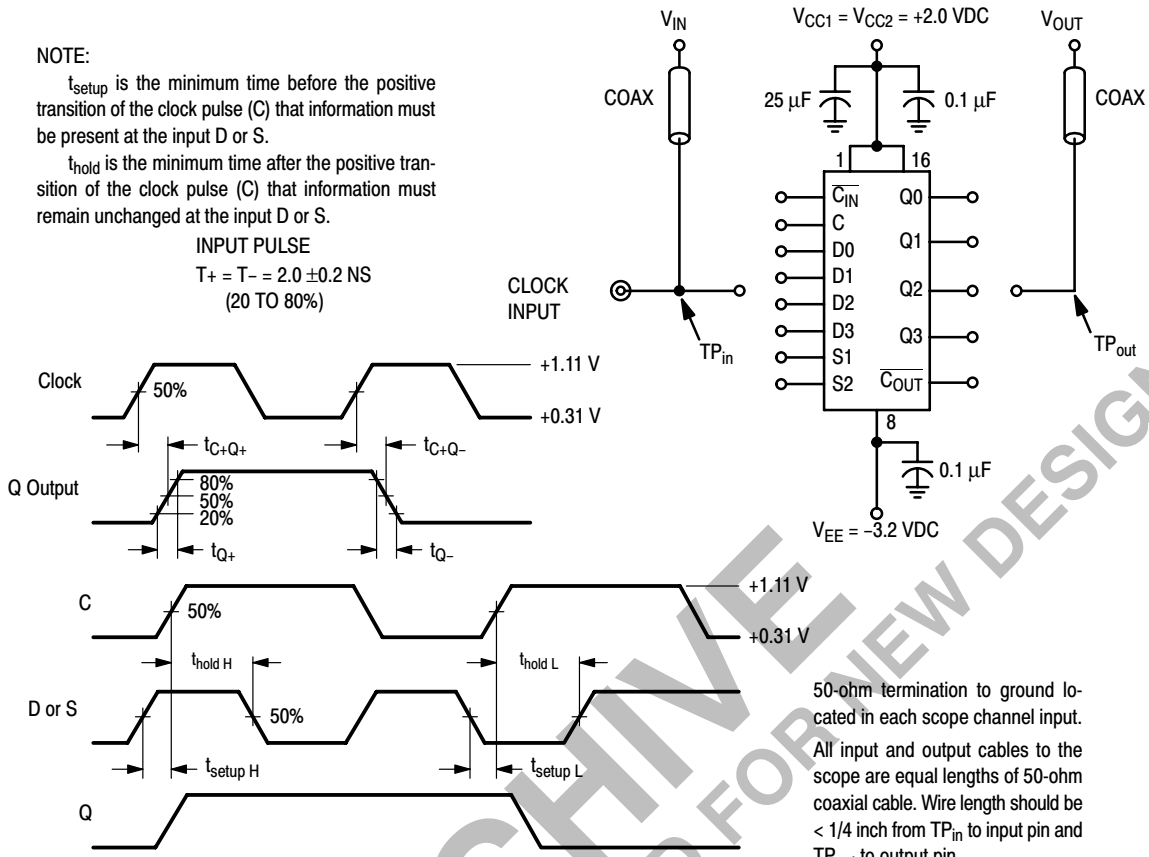

50-ohm termination to ground located in each scope channel input. All input and output cables to the scope are equal lengths of 50-ohm coaxial cable. Wire length should be < 1/4 inch from TP<sub>in</sub> to input pin and TP<sub>out</sub> to output pin. Unused outputs are connected to a 50-ohm resistor to ground.

### CARRY IN SET UP AND HOLD TIMES

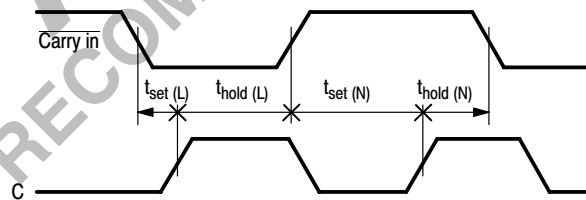

APPLICATIONS INFORMATION

To provide more than four bits of counting capability several MC10136 counters may be cascaded. The  $\overline{\text{Carry In}}$  input overrides the clock when the counter is either in the increment mode or the decrement mode of operation. This input allows several devices to be cascaded in a fully synchronous multistage counter as illustrated in Figure 1. The carry is advanced between stages as shown with no external gating. The  $\overline{\text{Carry In}}$  of the first device may be left open. The system clock is common to all devices.

The various operational modes of the counter make it useful for a wide variety of applications. If used with MECL III devices, prescalers with input toggle frequencies in excess of 300 MHz are possible. Figure 2 shows such a prescaler using the MC10136 and MC1670. Use of the MC10231 in place of the MC1670 permits 200 MHz operation.

The MC10136 may also be used as a programmable counter. The configuration of Figure 3 requires no additional gates, although maximum frequency is limited to about 50 MHz. The divider modulus is equal to the program input plus one ( $M = N + 1$ ), therefore, the counter will divide by a modulus varying from 1 to 16.

A second programmable configuration is also illustrated in Figure 4. A pulse swallowing technique is used to speed the counter operation up to 110 MHz typically. The divider modulus for this figure is equal to the program input ( $M = N$ ). The minimum modulus is 2 because of the pulse swallowing technique, and the modulus may vary from 2 to 15. This programmable configuration requires an additional gate, such as  $1/2$ MC10109 and a flip-flop such as  $1/2$ MC10131.

Figure 1. 12 BIT SYNCHRONOUS COUNTER

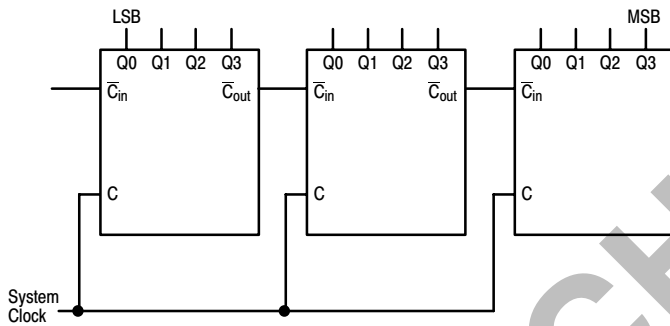

NOTE: S1 and S2 are set either for increment or decrement operation.

Figure 2. 300 MHz PRESCALER

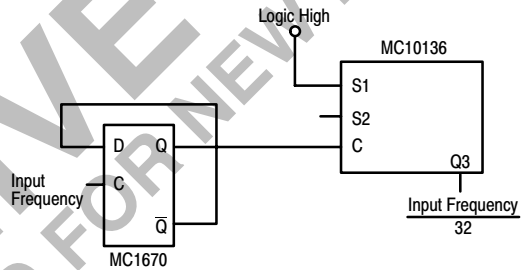
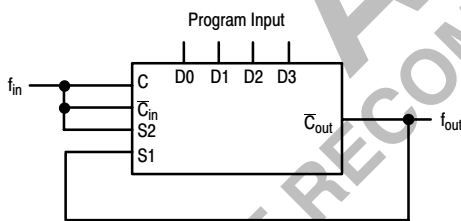
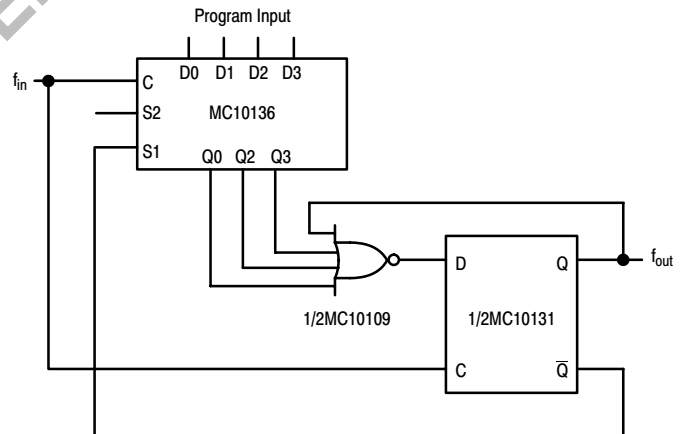

Figure 3. 50 MHz PROGRAMMABLE COUNTER



- 1  $f_{out} = \frac{f_{in}}{\text{Program Input} + 1}$
- 2  $f_{max} \cong 50 \text{ MHz Typ.}$
- 3 Divide Ratio is from 1 to 16.

Figure 4. 100 MHz PROGRAMMABLE COUNTER



- 1  $f_{out} = \frac{f_{in}}{\text{Program Input}}$
- 2  $f_{max} \cong 110 \text{ MHz Typ.}$
- 3 Divide Ratio is from 2 to 15.

# MC10136

## PACKAGE DIMENSIONS

PLCC-20  
FN SUFFIX  
PLASTIC PLCC PACKAGE  
CASE 775-02  
ISSUE C

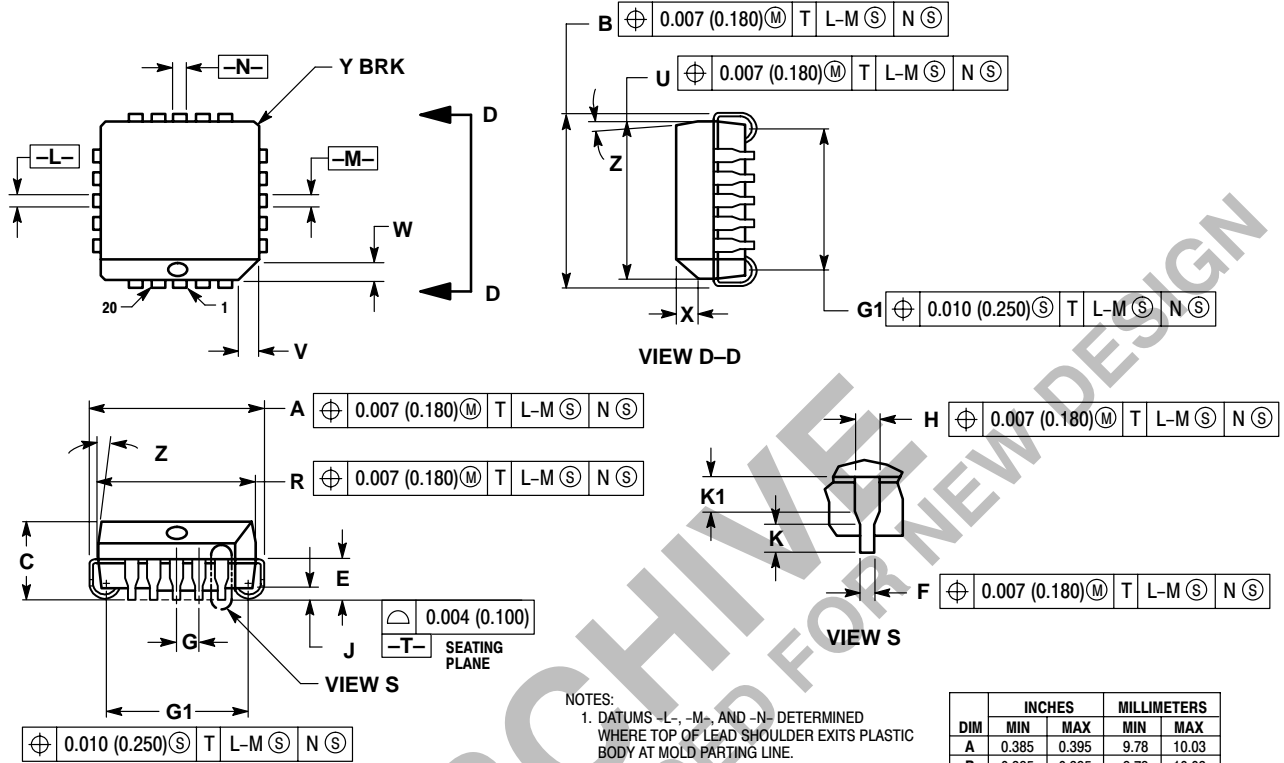

### NOTES:

- DATUMS -L-, -M-, AND -N- DETERMINED WHERE TOP OF LEAD SHOULDER EXITS PLASTIC BODY AT MOLD PARTING LINE.
- DIMENSION G1, TRUE POSITION TO BE MEASURED AT DATUM -T-, SEATING PLANE.
- DIMENSIONS R AND U DO NOT INCLUDE MOLD FLASH. ALLOWABLE MOLD FLASH IS 0.010 (0.250) PER SIDE.
- DIMENSIONING AND TOLERANCING PER ANSI Y14.5M, 1982.
- CONTROLLING DIMENSION: INCH.
- THE PACKAGE TOP MAY BE SMALLER THAN THE PACKAGE BOTTOM BY UP TO 0.012 (0.300). DIMENSIONS R AND U ARE DETERMINED AT THE OUTERMOST EXTREMES OF THE PLASTIC BODY EXCLUSIVE OF MOLD FLASH, TIE BAR BURRS, GATE BURRS AND INTERLEAD FLASH, BUT INCLUDING ANY MISMATCH BETWEEN THE TOP AND BOTTOM OF THE PLASTIC BODY.
- DIMENSION H DOES NOT INCLUDE DAMBAR PROTRUSION OR INTRUSION. THE DAMBAR PROTRUSION(S) SHALL NOT CAUSE THE H DIMENSION TO BE GREATER THAN 0.037 (0.940). THE DAMBAR INTRUSION(S) SHALL NOT CAUSE THE H DIMENSION TO BE SMALLER THAN 0.025 (0.635).

DIM	INCHES		MILLIMETERS	
	MIN	MAX	MIN	MAX
A	0.385	0.395	9.78	10.03
B	0.385	0.395	9.78	10.03
C	0.165	0.180	4.20	4.57
E	0.090	0.110	2.29	2.79
F	0.013	0.019	0.33	0.48
G	0.050 BSC		1.27 BSC	
H	0.026	0.032	0.66	0.81
J	0.020	---	0.51	---
K	0.025	---	0.64	---
R	0.350	0.356	8.89	9.04
U	0.350	0.356	8.89	9.04
V	0.042	0.048	1.07	1.21
W	0.042	0.048	1.07	1.21
X	0.042	0.056	1.07	1.42
Y	---	0.020	---	0.50
Z	2°	10°	2°	10°
G1	0.310	0.330	7.88	8.38
K1	0.040	---	1.02	---

# MC10136

## CDIP-16 L SUFFIX CERAMIC DIP PACKAGE CASE 620-10 ISSUE T

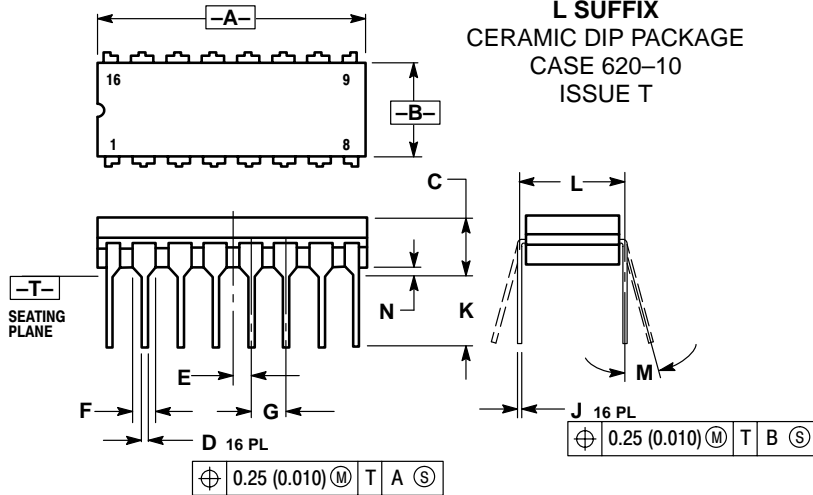

- NOTES:
1. DIMENSIONING AND TOLERANCING PER ANSI Y14.5M, 1982.
  2. CONTROLLING DIMENSION: INCH.
  3. DIMENSION L TO CENTER OF LEAD WHEN FORMED PARALLEL.
  4. DIMENSION F MAY NARROW TO 0.76 (0.030) WHERE THE LEAD ENTERS THE CERAMIC BODY.

DIM	INCHES		MILLIMETERS	
	MIN	MAX	MIN	MAX
A	0.750	0.785	19.05	19.93
B	0.240	0.295	6.10	7.49
C	---	0.200	---	5.08
D	0.015	0.020	0.39	0.50
E	0.050 BSC		1.27 BSC	
F	0.055	0.065	1.40	1.65
G	0.100 BSC		2.54 BSC	
H	0.008	0.015	0.21	0.38
K	0.125	0.170	3.18	4.31
L	0.300 BSC		7.62 BSC	
M	0°	15°	0°	15°
N	0.020	0.040	0.51	1.01

## PDIP-16 P SUFFIX PLASTIC DIP PACKAGE CASE 648-08 ISSUE R

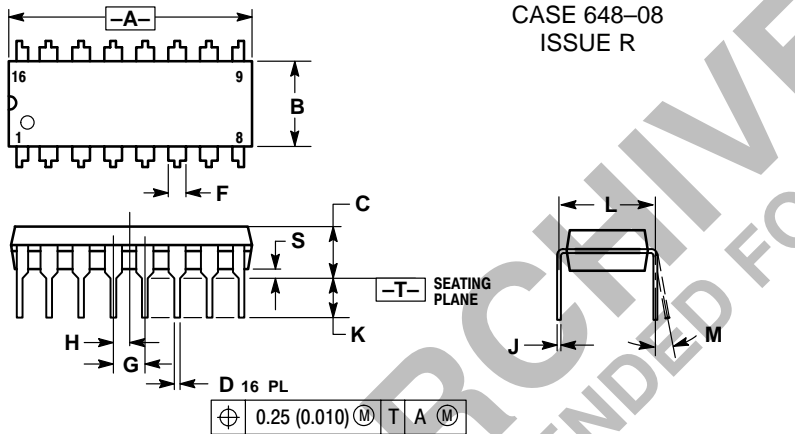

- NOTES:
1. DIMENSIONING AND TOLERANCING PER ANSI Y14.5M, 1982.
  2. CONTROLLING DIMENSION: INCH.
  3. DIMENSION L TO CENTER OF LEADS WHEN FORMED PARALLEL.
  4. DIMENSION B DOES NOT INCLUDE MOLD FLASH.
  5. ROUNDED CORNERS OPTIONAL.

DIM	INCHES		MILLIMETERS	
	MIN	MAX	MIN	MAX
A	0.740	0.770	18.80	19.55
B	0.250	0.270	6.35	6.85
C	0.145	0.175	3.69	4.44
D	0.015	0.021	0.39	0.53
F	0.040	0.70	1.02	1.77
G	0.100 BSC		2.54 BSC	
H	0.050 BSC		1.27 BSC	
J	0.008	0.015	0.21	0.38
K	0.110	0.130	2.80	3.30
L	0.295	0.305	7.50	7.74
M	0°	10°	0°	10°
S	0.020	0.040	0.51	1.01

ON Semiconductor and are trademarks of Semiconductor Components Industries, LLC (SCILLC). SCILLC reserves the right to make changes without further notice to any products herein. SCILLC makes no warranty, representation or guarantee regarding the suitability of its products for any particular purpose, nor does SCILLC assume any liability arising out of the application or use of any product or circuit, and specifically disclaims any and all liability, including without limitation special, consequential or incidental damages. "Typical" parameters which may be provided in SCILLC data sheets and/or specifications can and do vary in different applications and actual performance may vary over time. All operating parameters, including "Typicals" must be validated for each customer application by customer's technical experts. SCILLC does not convey any license under its patent rights nor the rights of others. SCILLC products are not designed, intended, or authorized for use as components in systems intended for surgical implant into the body, or other applications intended to support or sustain life, or for any other application in which the failure of the SCILLC product could create a situation where personal injury or death may occur. Should Buyer purchase or use SCILLC products for any such unintended or unauthorized application, Buyer shall indemnify and hold SCILLC and its officers, employees, subsidiaries, affiliates, and distributors harmless against all claims, costs, damages, and expenses, and reasonable attorney fees arising out of, directly or indirectly, any claim of personal injury or death associated with such unintended or unauthorized use, even if such claim alleges that SCILLC was negligent regarding the design or manufacture of the part. SCILLC is an Equal Opportunity/Affirmative Action Employer.

### PUBLICATION ORDERING INFORMATION

#### Literature Fulfillment:

Literature Distribution Center for ON Semiconductor  
P.O. Box 5163, Denver, Colorado 80217 USA  
Phone: 303-675-2175 or 800-344-3860 Toll Free USA/Canada  
Fax: 303-675-2176 or 800-344-3867 Toll Free USA/Canada  
Email: ONlit@hibbertco.com

N. American Technical Support: 800-282-9855 Toll Free USA/Canada

JAPAN: ON Semiconductor, Japan Customer Focus Center  
4-32-1 Nishi-Gotanda, Shinagawa-ku, Tokyo, Japan 141-0031  
Phone: 81-3-5740-2700  
Email: r14525@onsemi.com

ON Semiconductor Website: <http://onsemi.com>

For additional information, please contact your local Sales Representative.