

# SPECIFICATIONS

PARAMETERS	VALUES	UNITS
RATED INPUT POWER	0.5	W
MAX INPUT POWER	0.8	W
IMPEDANCE	8 ± 15%	OHM
OUTPUT SPL @ 0.5W/0.1M (AT 0.8, 1.0, 1.2, 1.5, KHZ)	94 ± 3	dBA
DISTORTION (MAX.)	5%	-
RESONANT FREQUENCY	700 ± 20%	Hz
FREQUENCY RANGE	700 ~ 4,800	Hz
HOUSING MATERIAL	METAL	-
CONE MATERIAL	TREATED PAPER	-
MAGNET MATERIAL	Nd-Fe-B	-
OPERATING TEMPERATURE	-20 ~ +60	°C
WEIGHT	9	grams

THIS DOCUMENT CONTAINS DATA PROPRIETARY TO PROJECTS UNLIMITED, INC. ANY USE OR REPRODUCTION, IN ANY FORM, WITHOUT PRIOR WRITTEN PERMISSION OF PROJECTS UNLIMITED, INC. IS PROHIBITED.  
©2003, Projects Unlimited Inc.

# REVISION HISTORY

LTR	DESCRIPTION	DATE	APPROVED
-	RELEASED FROM ENGINEERING	9/25/2006	
A	REVISED TO INVENTOR 3-D DRAWING TEMPLATE	10/21/2008	B.R.
B	ADDED NOTE 5	8/12/2011	B.R.
c	REVISED SPL, DIMENSIONS, AND ROHS STATUS	9/26/2013	R.W.

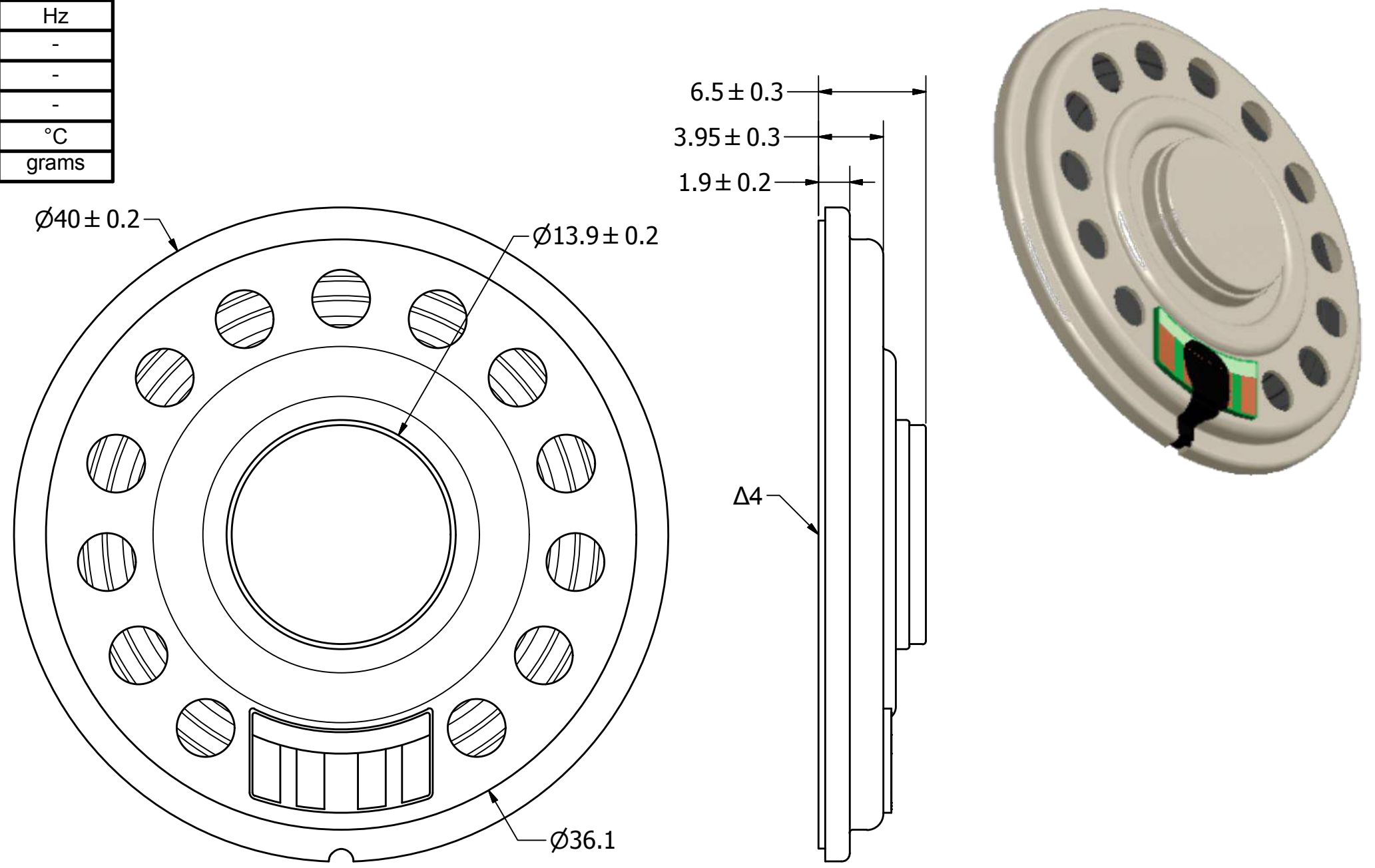

## NOTES:

1. ALL DIMENSIONS ARE IN MILLIMETERS.
2. SPECIFICATIONS SUBJECT TO CHANGE OR WITHDRAWL WITHOUT NOTICE.
3. THIS PART IS RoHS 2011/65/EU COMPLIANT.
- Δ4. CONE HAS BEEN TREATED FOR WATER RESISTANCE.
5. BASE SPEAKER PUI# AS04008PR-R.

UNLESS OTHERWISE SPECIFIED: DIMENSIONS ARE IN MILLIMETERS, TOLERANCES ARE ±0.5 AND ANGLES ARE ±3°.	SIZE <b>A3</b>	Designed by	Date	Checked by	Date	Approved by	Date	Drawn Date
		J.D.	9/25/2006	B.R.	9/25/2006	R.W.	9/25/2006	10/21/2008
AS04008PR-WR-R.idw		 <b>pui audio</b> a projects unlimited company		<b>AS04008PR-WR-R</b> Speaker			Edition	Sheet
							-	1 / 1