



SPECIFICATION SHEET

SPECIFICATION SHEET NO.	N0310- SOT23SM120SM12
DATE	Mar. 10, 2021
REVISION	A0
DESCRIPTION	<p>SMD Plastic-Encapsulate ESD Protection Diodes, SOT-23 series, 3 pads SM12 Type, Uni-directional TVS Diodes Array Reverse Working Voltage : 12V, Peak Pulse Power per (8/20μs): 350 Watts Operating Temp. Range -55°C ~+150°C, Package in Tape/Reel, 3000pcs/Reel RoHS/RoHS III compliant</p>
CUSTOMER	
CUSTOMER PART NUMBER	
CROSS REF. PART NUMBER	
ORIGINAL PART NUMBER	MDD SM12
PART CODE	SOT23SM120SM12

VENDOR APPROVE		
Issued/Checked/Approved		
		
DATE: March 10, 2021		

CUSTOMER APPROVE
DATE:

SMD ESD PROTECTION DIODES (TUBE) SOT23 SERIES

MAIN FEATURE

- 350 Watts Peak Pulse Power per (8/20μs)
- IEC61000-4-2 (ESD) ±15kV (air), ±8kV (contact)
- IEC61000-4-4 (EFT) 40A (5/50ns)
- Protects one bidirectional line or two unidirectional lines
- Low clamping voltage
- Low leakage current
- Working voltages : 3V, 5V, 8V, 12V, 15V, 18V, 20V, 24V, 36V
- Meets MSL 1 Requirements



APPLICATION

- Cell Phone Handsets and Accessories
- Microprocessor based equipment
- Personal Digital Assistants (PDA's)
- Notebooks, Desktops, and Servers
- Portable Instrumentation
- Networking and Telecom
- Serial and Parallel Ports
- Peripherals

RFQ

[Request For Quotation](#)

PART CODE GUIDE

SOT23	SM120	S	M12
1	2	3	4

1) **SOT23**: SMD Plastic-Encapsulate ESD Protection Diodes, SOT-23 series, 3 pads

2) **SM120**: Type code for SM12

3) **S**: Package code, Package in Tape/Reel, 3000pcs/Reel

4) **M12**: Marking code for "M12" on the case surface, Different Marking for different specification.

MORE ITEMS AVAILABLE (Uni-directional)

SOT23SM030SM03	SOT23SM050SM05	SOT23SM080SM08	SOT23SM120SM12	SOT23SM150SM15
SOT23SM180SM18	SOT23SM200SM20	SOT23SM240SM24	SOT23SM300SM30	

SMD ESD PROTECTION DIODES (TUBE) SOT23 SERIES

DIMENSION (Unit: Inch/mm)

Image for reference

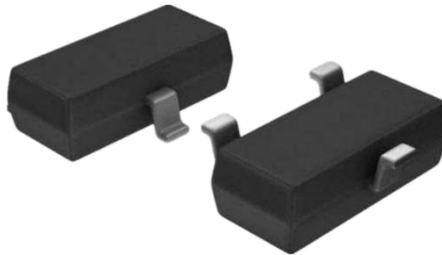

Marking: M12

SOT-23

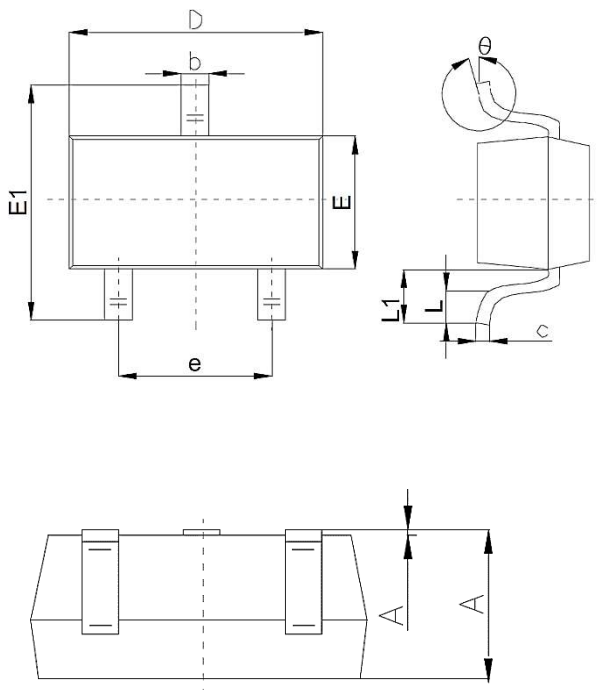

Symbol	Value (mm)		
	Min.	Typ.	Max.
A	1.0		1.4
A1			0.10
b	0.35		0.50
c	0.10		0.20
D	2.70	2.90	3.10
E	1.40		1.60
E1	2.40		2.80
e		1.9	
L	0.10		0.30
L1	0.40		
θ	0°		10°

Recommend Pad Layout

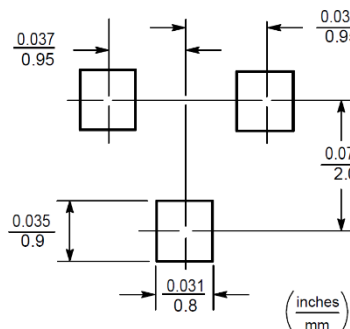

Circuit Diagram

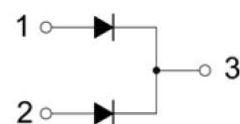

- 1.Base
- 2.Emitter
- 3.Collector

SMD ESD PROTECTION DIODES (TUBE) SOT23 SERIES
MECHANICAL DATA

Case	Terminals	Polarity	Mounting Position	Weight per piece
JEDEC SOT-23 molded plastic body	Matte tin plated	Polarity symbol marking on case	Any	0.00019 Ounce, 0.00591 grams

ABSOLUTE MAX. RATINGS AT Ta=25 °C (unless otherwise specified)

Parameter	SYMBOLS	VALUE	UNITS
		LIMIT	
ESD per IEC 61000-4-3 (Air)	V ESD	+/-15	KV
ESD per IEC 61000-4-2 (Contact)	V ESD	+/-8	KV
Peak Pulse Power(tp=8/20us waveform)	P PP	350	W
Lead Solder Temperature – Maximum (10 Second Duration)	T L	260	°C
Operating Temperature Range	TOPT	-55 ~+ 150	°C
Storage Temperature Range	T STG	-55 ~ +150	°C

ABSOLUTE MAX. RATINGS AT Ta=25 °C (unless otherwise specified)

Parameter	SYMBOLS	VALUE			UNITS
		Min.	Typical	Max.	
Reverse Working Voltage	V RWM			12.0	V
Reverse Breakdown Voltage @ IT = 1.0mA	V BR	13.3			V
Test Circuit	I T		1.0		μA
Clamping Voltage @ I PP = 1A	V C			24	V
Clamping Voltage @ I PP = 10A	V C			38	V
Reverse Leakage Current	I R			1.0	μA
Junction Capacitance	C T			120	pF

SMD ESD PROTECTION DIODES (TUBE) SOT23 SERIES
ELECTRICAL CHARACTERISTICS AT Ta= 25 °C

Parameter	SYMBOLS	VALUE			UNIT	Condition
		Min.	Typ.	Max.		
Collector-base breakdown voltage	$V_{(BR)CBO}$	75			V	$I_C = 10\mu A, I_E = 0$
Collector-emitter breakdown voltage	$V_{(BR)CEO}^*$	40			V	$I_C = 10mA, I_B = 0$
Emitter-base breakdown voltage	$V_{(BR)EBO}$	6			V	$I_E = 10\mu A, I_C = 0$
Collector cut-off current	I_{CBO}			0.01	μA	$V_{CB} = 60V, I_E = 0$
Collector cut-off current	I_{CEX}			0.01	μA	$V_{CE} = 30V, V_{BE(off)} = 3V$
Emitter cut-off current	I_{EBO}			0.1	μA	$V_{EB} = 3V, I_C = 0$
DC Current gain	$h_{FE(1)}^*$	100		300		$V_{CE} = 10V, I_C = 150mA$
	$h_{FE(2)}$	40				$V_{CE} = 10V, I_C = 0.1mA$
	$h_{FE(3)}^*$	42				$V_{CE} = 10V, I_C = 500mA$
Collector-emitter saturation voltage	$V_{CE(sat)}^*$			1	V	$I_C = 500mA, I_B = 50mA$ $I_C = 150mA, I_B = 15mA$
				0.3		
Base-emitter saturation voltage	$V_{BE(sat)}^*$			2.0	V	$I_C = 500mA, I_B = 50mA$ $I_C = 150mA, I_B = 15mA$
				1.2		
Transition frequency	f_T	300			MHz	$V_{CE} = 20V, I_C = 20mA, f = 100MHz$
Delay time	t_d			10	ns	$V_{CC} = 30V, V_{BE(off)} = -0.5V$ $I_C = 150mA, I_{B1} = 15mA$
Rise time	t_r			25	ns	
Storage time	t_s			225	ns	$V_{CC} = 30V, I_C = 150mA$ $I_{B1} = -I_{B2} = 15mA$
Fall time	t_f			60	ns	

Note: * pulse test: Pulse Width $\leq 300\mu s$, Duty Cycles $\leq 2.0\%$.

CLASSIFICATION OF h_{FE}

Rank	L	H
Range	100 ~ 200	200 ~ 300
Marking	1P	1P

SMD ESD PROTECTION DIODES (TUBE) SOT23 SERIES
RELIABILITY

Number	Experiment Items	Experiment Method And Conditions	Reference Documents
1	Solder Resistance Test	Test 260°C± 5°C for 10 ± 2 sec. Immerse body into solder 1/16" ± 1/32"	MIL-STD-750D METHOD-2031.2
2	Solderability Test	230°C ±5°C for 5 sec.	MIL-STD-750D METHOD-2026.1 0
3	Pull Test	1 kg in axial lead direction for 10 sec.	MIL-STD-750D METHOD-2036.4
4	Bend Test	0.5Kg Weight Applied To Each Lead, Bending Arcs 90 °C ± 5 °C For 3 Times	MIL-STD-750D METHOD-2036.4
5	High Temperature Reverse Bias Test	TA=100°C for 1000 Hours at VR=80% Rated VR	MIL-STD-750D METHOD-1038.4
6	Forward Operation Life Test	TA=25°C Rated Average Rectified Current	MIL-STD-750D METHOD-1027.3
7	Intermittent Operation Life Test	On state: 5 min with rated IRMS Power Off state: 5 min with Cool Forced Air. On and off for 1000 cycles.	MIL-STD-750D METHOD-1036.3
8	Pressure Cooker Test	15 PSIG, TA=121°C, 4 hours	MIL-S-19500 APPENOIXC
9	Temperature Cycling Test	-55°C~+125°C; 30 Minutes For Dwelled Time 5 minutes for transferred time. Total: 10 cycles.	MIL-STD-750D METHOD-1051.7
10	Thermal Shock Test	0°C for 5 minutes., 100°C for 5minutes, Total: 10 cycles	MIL-STD-750D METHOD-1056.7
11	Forward Surge Test	8.3ms Single Sale Sine-wave One Surge.	MIL-STD-750D METHOD-4066.4
12	Humidity Test	TA=65°C, RH=98% for 1000 hours.	MIL-STD-750D METHOD-1021.3
13	High Temperature Storage life Test	150°C for 1000 Hours	MIL-STD-750D METHOD-1031.5

SMD ESD PROTECTION DIODES (TUBE) SOT23 SERIES

SUGGESTED REFLOW PROFILE (For Reference Only)

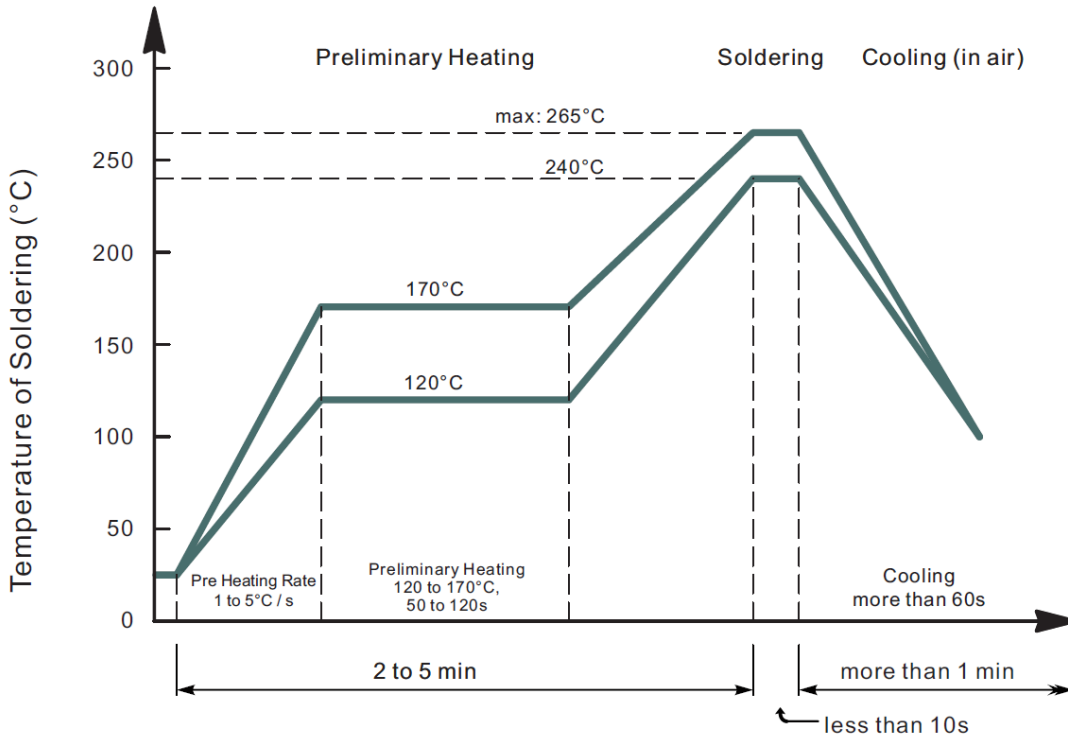

- Recommended peak temperature is over 245°C, If peak temperature is below 245 °C, you may adjust the following parameters; time length of peak temperature (longer), time length of soldering (longer), thickness of solder paste (thicker)
- Welding shall not exceed 2 times
- Remark: lead free solder paste (96.5 sn/3.0 Ag/0.5Cu)

SMD ESD PROTECTION DIODES (TUBE) SOT23 SERIES

RATINGS AND CHARACTERISTIC CURVES (For Reference Only)

Power Derating Curve

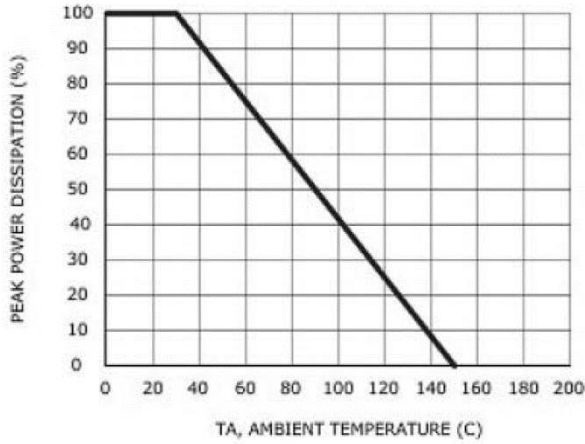

Pulse Waveform

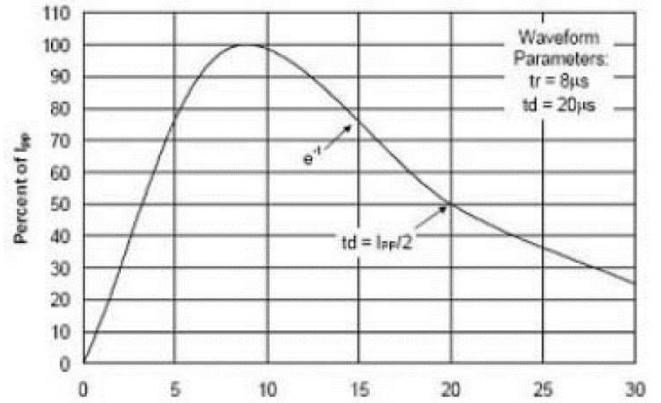

SMD ESD PROTECTION DIODES (TUBE) SOT23 SERIES

TAPE/REEL (Unit: mm)

All Devices are packed in accordance with EIA standard RS-481-A and specifications.

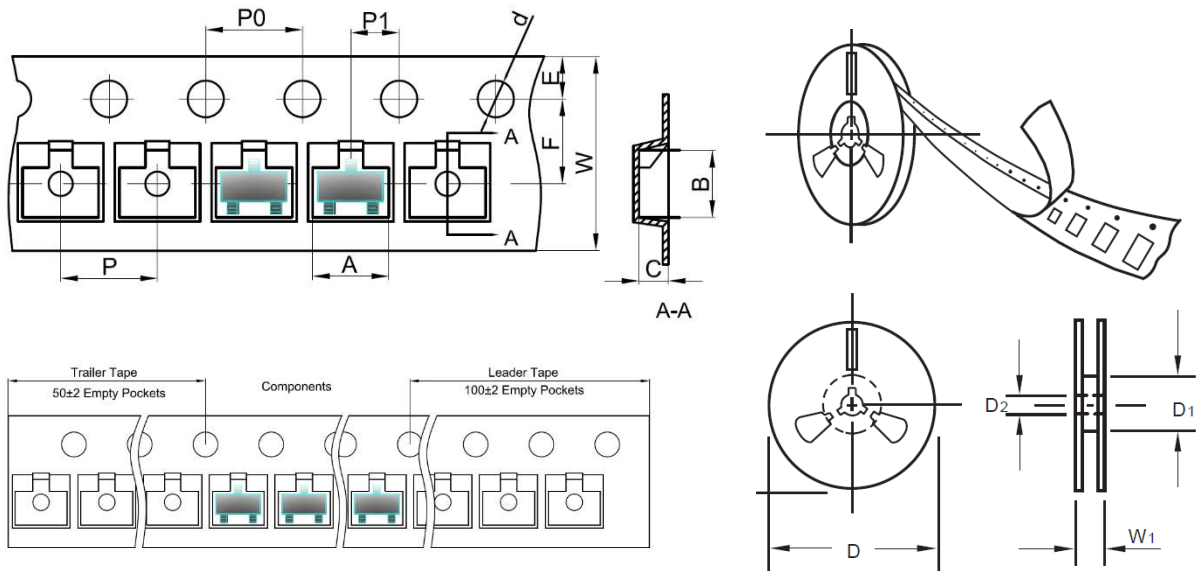

Item	Symbol	Tolerance	SOT-23
Carrier width	A	0.1	3.15
Carrier Length	B	0.1	2.77
Carrier Depth	C	0.1	1.22
Sprocket hole	d	0.05	1.55
7"Reel outside diameter	D	2.0	178.00
7"Reel inner diameter	D1	Min.	54.4
Feed hole diameter	D2	0.5	13.00
Sprocket hole position	E	0.1	1.75
Punch hole position	F	0.1	3.50
Punch hole pitch	P	0.1	4.00
Sprocket hole pitch	P0	0.1	4.00
Embossment center	P1	0.1	2.00
Overall tape thickness	T	0.1	0.25
Tape width	W	0.3	8.00
Reel width	W1	1.0	19.50

SMD ESD PROTECTION DIODES (TUBE) SOT23 SERIES

PACKAGE

Case Code	Reel Size	MPQ (pcs)	Component Spacing (mm)	Qty. Per Box (pcs)	Inner Box L*W*H (mm)	Reel Size (mm)	Carton size L*W*H (mm)	Qty. Per Carton (pcs)	G. W (kg)
SOT-23	7"	3,000		45,000	212*207*207	178	430*430*230	180,000	6.5

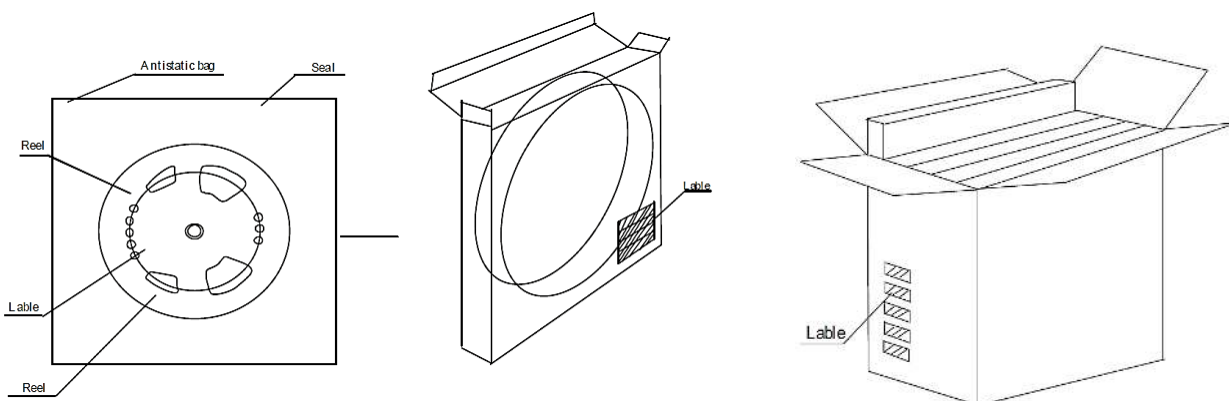

DISCLAIMER

NextGen Component, Inc. reserves the right to make changes to the product(s) and or information contained herein without notice. No liability is assumed as a result of their use or application. No rights under any patent accompany the sale of any such product(s) or information