

THIS DRAWING IS UNPUBLISHED. RELEASED FOR PUBLICATION
 © COPYRIGHT BY TYCO ELECTRONICS CORPORATION. ALL RIGHTS RESERVED.

LOC		DIST		REVISIONS			
P	LTR	DESCRIPTION	DATE	DWN	APVD		
AF	50	T	REVISED PER 0G3A-0170-05	30JUN05	MF	EH	
		T1	REVISED PER ECO-09-021510	04SEP09	KK	AEG	

- 1 OPERATION TEMPERATURE IS 105° C MAX.
- 2 RETENTION FORCE - 16 OUNCES MIN INITIALLY.
6 OUNCES MIN AFTER 500 CYCLES.
- 3 REFER TO MOUNTING HOLE PATTERN.
- 4 .175 MAX TO BE MEASURED ACROSS THE CUT-OFF TABS.
- 5 OBSOLETE PARTS: OBSOLETE CIS STREAMLINING PER D.RENAUD/D.SINISI

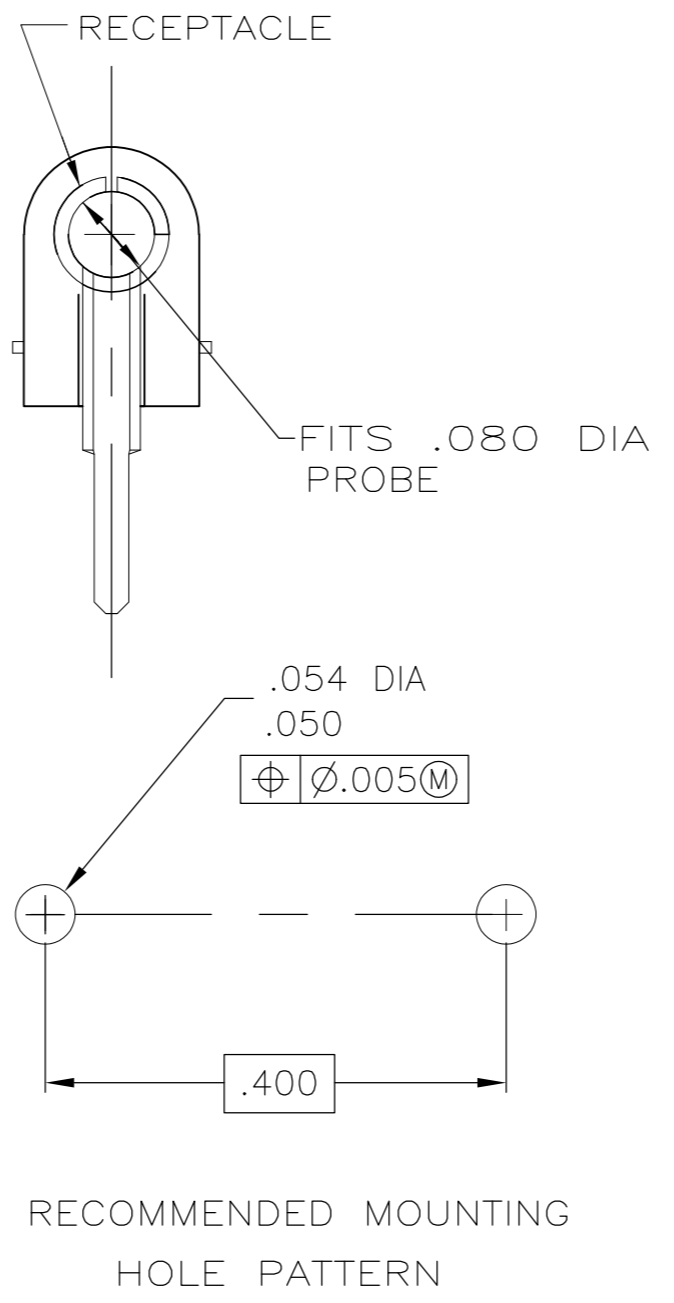
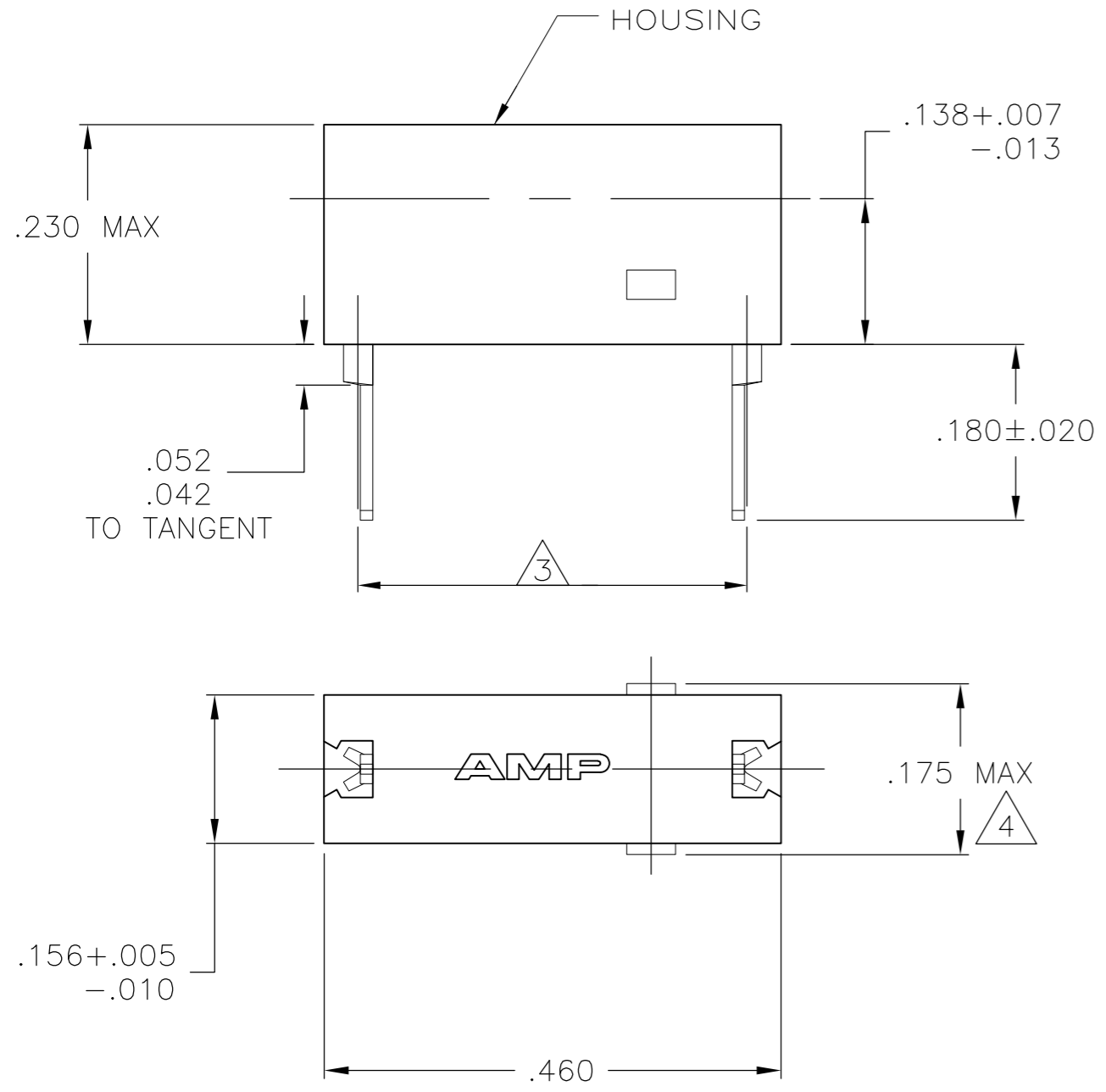

5	SUPERCEDED	NYLON 6/6; GREEN	BRASS - TIN-LEAD	3-380736-5
	OBSOLETE	NYLON 6/6; NATURAL	BRASS - GOLD	2-380736-0
		NYLON 6/6; WHITE	BRASS - GOLD	1-380736-9
	OBSOLETE	NYLON 6/6; GRAY	BRASS - GOLD	1-380736-8
	OBSOLETE	NYLON 6/6; VIOLET	BRASS - GOLD	1-380736-7
	OBSOLETE	NYLON 6/6; BLUE	BRASS - GOLD	1-380736-6
	OBSOLETE	NYLON 6/6; GREEN	BRASS - GOLD	1-380736-5
	OBSOLETE	NYLON 6/6; YELLOW	BRASS - GOLD	1-380736-4
	OBSOLETE	NYLON 6/6; ORANGE	BRASS - GOLD	1-380736-3
	OBSOLETE	NYLON 6/6; RED	BRASS - GOLD	1-380736-2
	OBSOLETE	NYLON 6/6; BROWN	BRASS - GOLD	1-380736-1
		NYLON 6/6; BLACK	BRASS - GOLD	1-380736-0
		HOUSING - MATERIAL; COLOR	RECEPTACLE - MATERIAL; FINISH	PART NUMBER

THIS DRAWING IS A CONTROLLED DOCUMENT.

DWN	M.S. FEHER	19APR2004	Tyco Electronics Corporation Harrisburg, Pa 17105-3608
CHK	E. HOWARD	19APR2004	
APVD	E. HOWARD	10APR2004	
PRODUCT SPEC	NAME		
DIMENSIONS: mm TOLERANCES UNLESS OTHERWISE SPECIFIED: 0 PLC ± - 1 PLC ± - 2 PLC ± .015 3 PLC ± - 4 PLC ± - ANGLES ± - FINISH SEE TABLE			ASSEMBLY, TEST PROBE - - SIZE CAGE CODE DRAWING NO RESTRICTED TO A2 00779 C=380736 - CUSTOMER DRAWING SCALE 6:1 SHEET 1 OF 1 REV T1

380736

A