

**STRAIGHT PLUG FULL CRIMP TYPE
CABLE 10/50 S**

R161.075.000
SERIES N

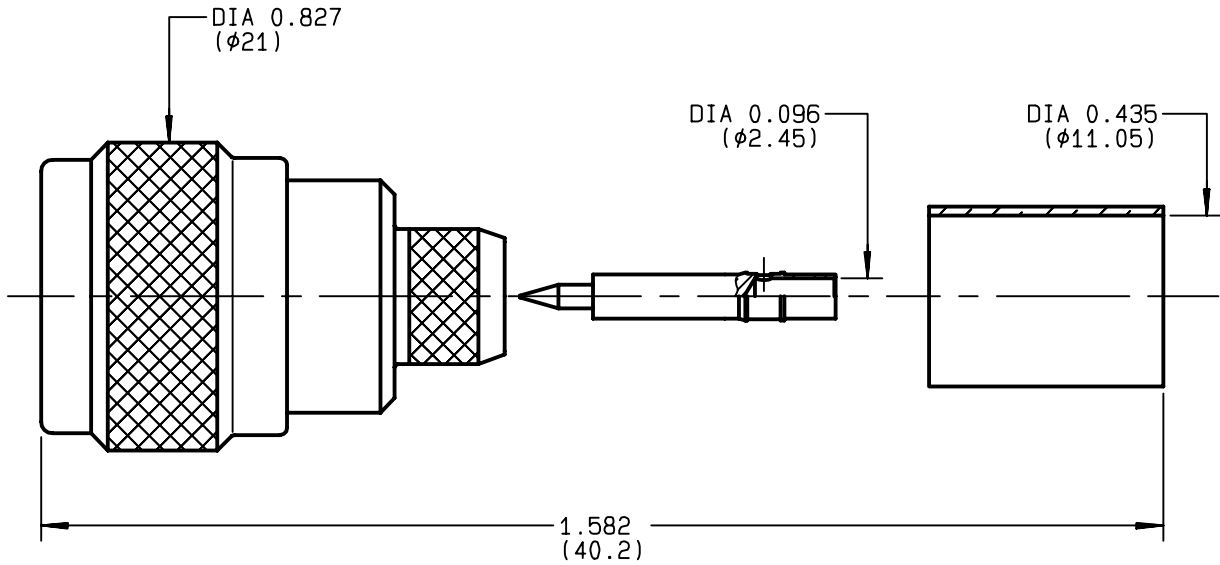

NOMINAL IMPEDANCE	50 Ω	CABLES : KX 4 RG 165 RG 213
FREQUENCY RANGE	0-11 GHz	
TEMPERATURE RATING	-55/+155 °C	
V.S.W.R	1.30 + x F(GHz)Maxi	
RF INSERTION LOSS	0.048 √F(GHz) dB Maxi	
VOLTAGE RATING	1400 Veff Maxi	
DIELECTRIC WITHSTANDING VOLTAGE	2500 Veff Mini	
INSULATION RESISTANCE	5000 MΩMini	
HERMETIC SEAL	NA Atm.cm ³ /s	
LEAKAGE (pressurized only)	NA	
MECHANICAL DURABILITY	500 Cycles	OTHERS CHARACTERISTICS
WEIGHT	35.8 gr	CABLE RETENTION 300 N Mini
SPECIFICATION		CENTER CONTACT RETENTION
		Axial force - mating end 68 N Mini
		Axial force - opposite end 68 N Mini
		Torque NA cm.N Mini
		RECOMMENDED TORQUES
		Mating 130 cm.N
		Panel nut NA cm.N
		Clamp nut NA cm.N

CONNECTOR PARTS	MATERIALS	FINISH	(all values are given) in micrometers
BODY	BRASS	BBR 2	
OUTER CONTACT	BRASS	BBR 2	
CENTER CONTACT	BRASS	GOLD 0.5 OVER NICKEL 2	
INSULATOR	PTFE	-	
GASKET	SILICONE RUBBER	-	
OTHERS PIECES	BRASS	BBR 2	

BONMINI

ISSUE 0243S02	CREATION DATE 21/07/1993	FILE PART-NUMBER EPC 96-07
-------------------------	------------------------------------	--------------------------------------



RADIALL®

The information given here is subject to change without notice.
Design changes may be in order to improve the product .

Connect to the future



R161.075.000

ISSUE **0243S02** SERIES **N**

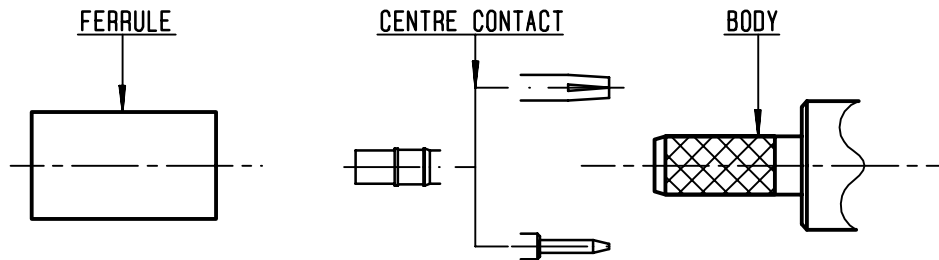

①

Slide onto the cable the ferrule
Strip the cable .
-
-

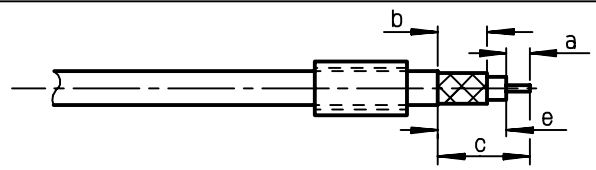

Stripping	a	b	c	d	e
inch	0.197	0.315	0.551	0	0.354
mm	5	8	14		9

②

Slide on centre contact until it bottoms against cable dielectrique .
Crimp centre contact .
Crimping tool : R282 231 000 (Hex. : .100)
or R282 293 000 (M22520/5-01)
+ dies R282 235 116 (Y 116 DANIELS).
-
-
-

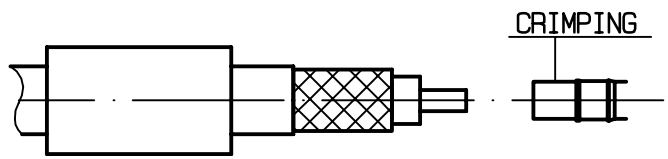

③

Fan the braid .
Slide cable dielectrique into the body while gently ginding the braid over the knurl
Push until the dielectrique clicks into position .
Slide ferrule over braid in direction F .

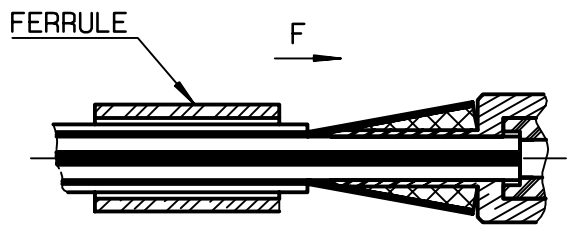

④

Crimp the ferrule with crimping tool R 282 231 000 (Hex. : .415) or crimping tool R282 293 000 (M22520/5-01) + dies R282 235 116 (Y 116 DANIELS).
Cut the excess of braid .
-
-

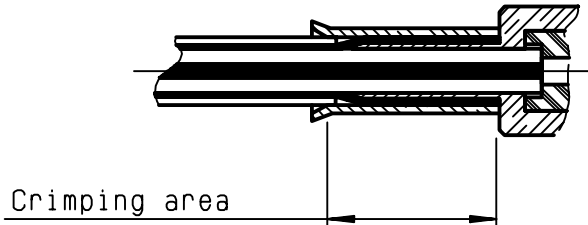

BONOMINI