

- 1 HOUSING MATERIAL: GLASS-FILLED POLYESTER. COLOR: GRAY.
- 2 CONTACT MATERIAL: PHOSPHOR BRONZE.
- 3 CONTACT FINISH: 0.00076[.000030] GOLD IN CONTACT AREA. 0.00127[.000050] NICKEL UNDERPLATE ALL OVER. TIN-LEAD ON POSTS.
- 4 PART NUMBER, DATE CODE IDENTIFICATION, CSA LOGO IN THIS APPROXIMATE AREA, ON REVERSE SIDE.
- 5 POINT OF MEASUREMENT FOR GOLD.
- 6 RECOMMENDED HOLE SIZE FOR MANUAL APPLICATION OF CONNECTOR ONTO PC BOARD.
- 7 CONTACT FINISH: 0.00127[.000050] GOLD IN CONTACT AREA. 0.00127[.000050] NICKEL UNDERPLATE ALL OVER. TIN-LEAD ON POSTS.
- 8 CONTACT FINISH: DIN 41612 CLASS 3 IN CONTACT AREA. TIN-LEAD ON POSTS.
- 9 CONTACT FINISH: DIN 41612 CLASS 2 IN CONTACT AREA. TIN-LEAD ON POSTS.
- 10 CONTACT FINISH: GOLD FLASH OVER 1.02µm[.000040] MIN PALLADIUM/NICKEL IN CONTACT MATING AREA, ALL OVER 1.27µm[.000050] MIN NICKEL. TIN-LEAD ON TAILS.

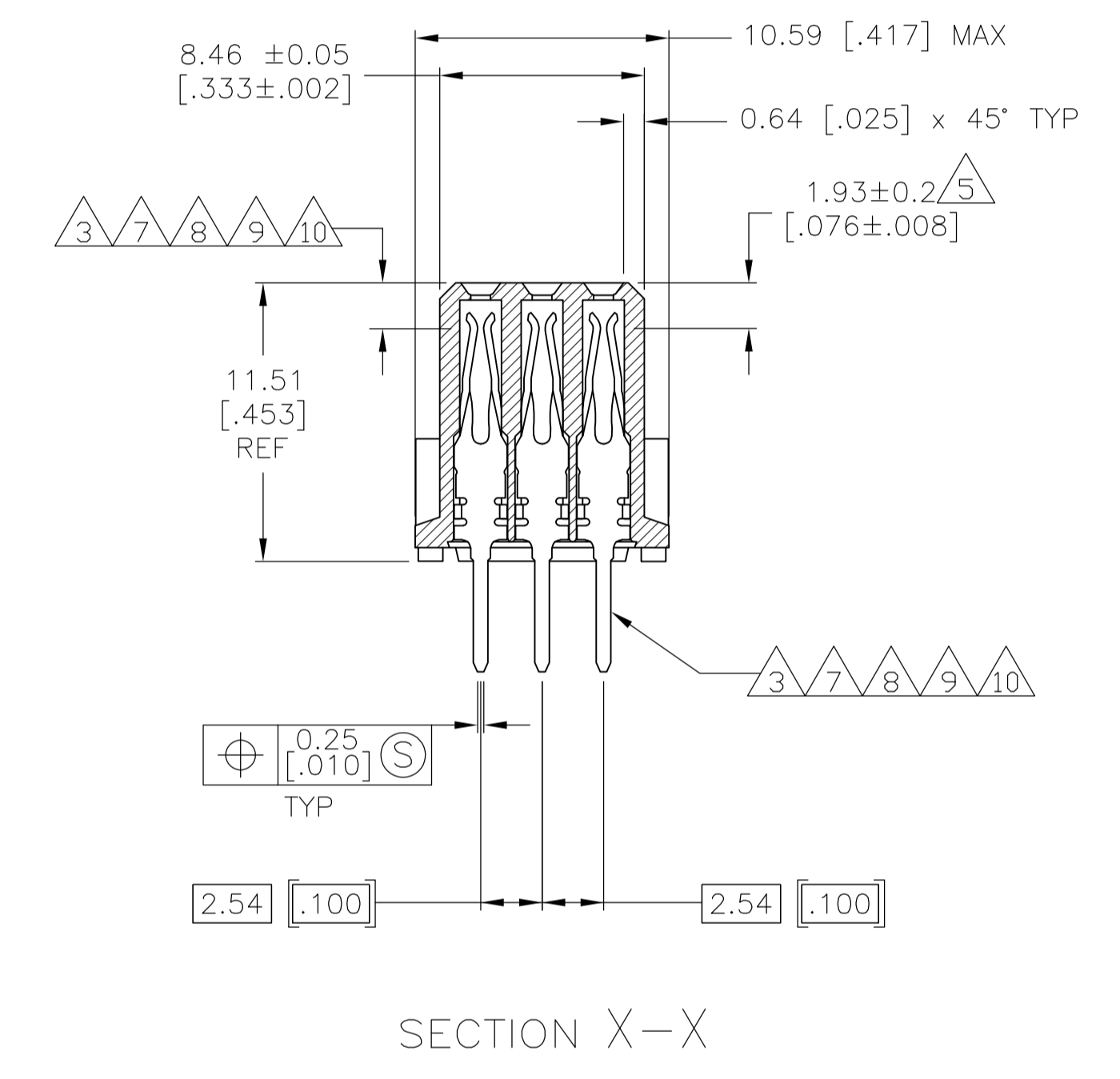

OBsolete	POSITIONS LOADED	C	B	A	NO. OF LOADED POSITION	ASSY PART NUMBER
OBsolete	1 THRU 32	X	X	X	96	535043-9
OBsolete	1 THRU 32	X	X	X	96	535043-6
	1 THRU 32	X	X	X	96	535043-5
	1 THRU 32	X	X	X	96	535043-4
OBsolete	1 THRU 32	X	X	X	96	535043-1

THIS DRAWING IS A CONTROLLED DOCUMENT.

DIMENSIONS: mm [INCHES]	TOLERANCES UNLESS OTHERWISE SPECIFIED:	DIN L BRINER 12/6/88	APVD R PATTERSON 12/5/93	NAME
0 PLC ± -	1 PLC ± -	12/5/93	R PATTERSON 12/5/93	ASSEMBLY, RECEPTACLE, EUROCARD, TYPE C, SOLDER TAIL, 96 POSITION
2 PLC ± -	3 PLC ± 0.13[.005]			APPLICATION SPEC
4 PLC ± -	ANGLES ± -			SIZE CASE CODE DRAWING NO
				A1 00779 C=535043
MATERIAL	FINISH	WEIGHT		RESTRICTED TO
				CUSTOMER DRAWING SCALE 4:1 SHEET 1 of 1 REV P1