

THIS DRAWING IS UNPUBLISHED. RELEASED FOR PUBLICATION 20
 © COPYRIGHT 20 BY - ALL RIGHTS RESERVED.

REVISIONS				
P	LTR	DESCRIPTION	DATE	APVD
B		UPDATE PER ECO-16-006041	13APR2016	DS CS

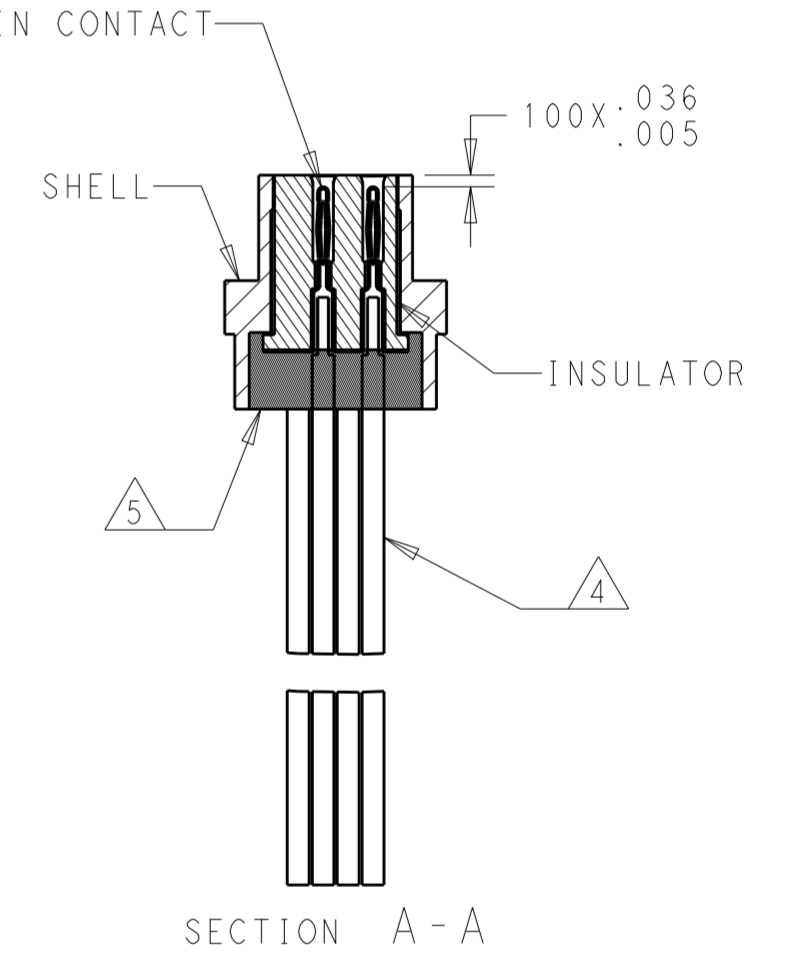
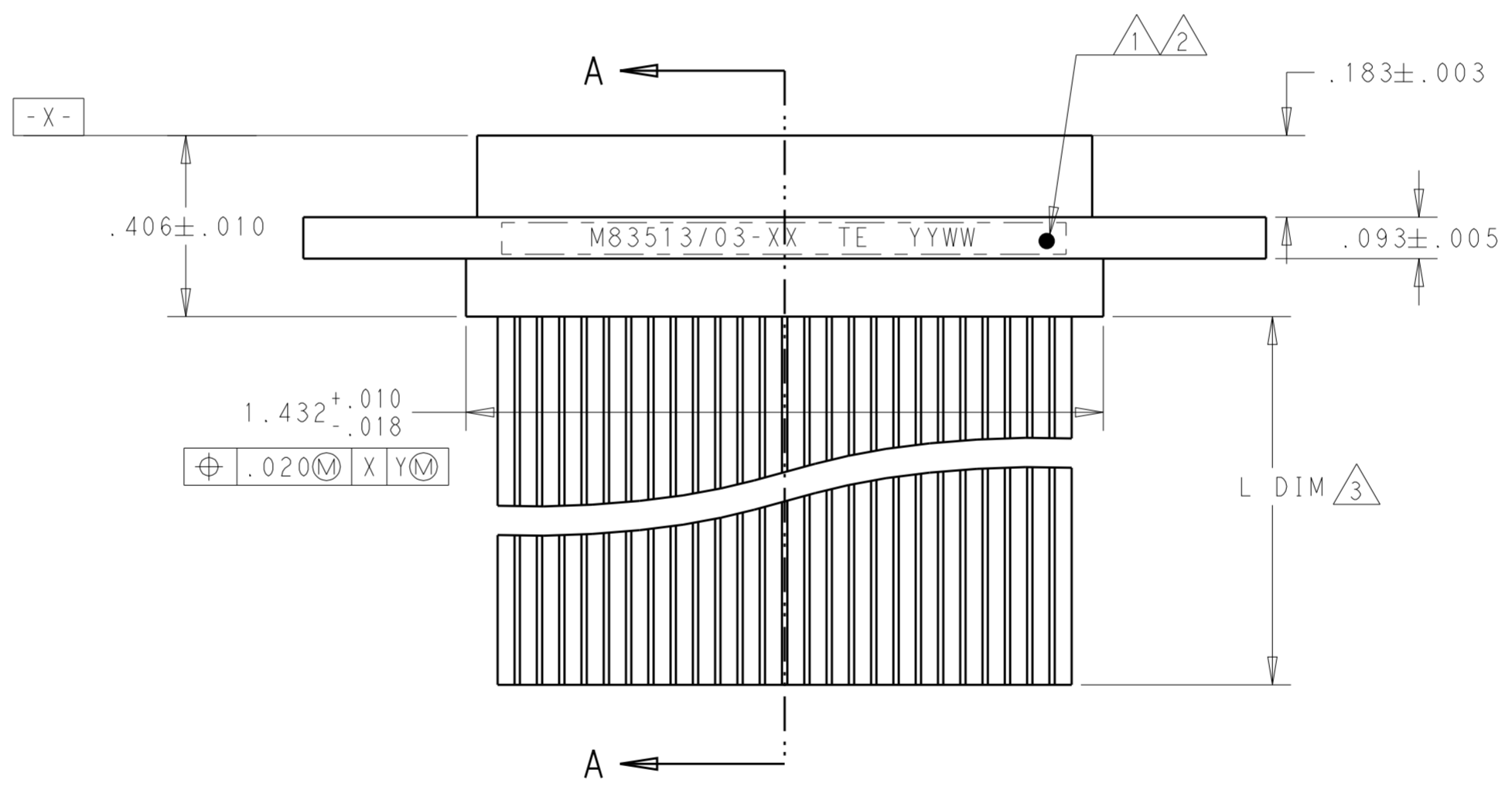
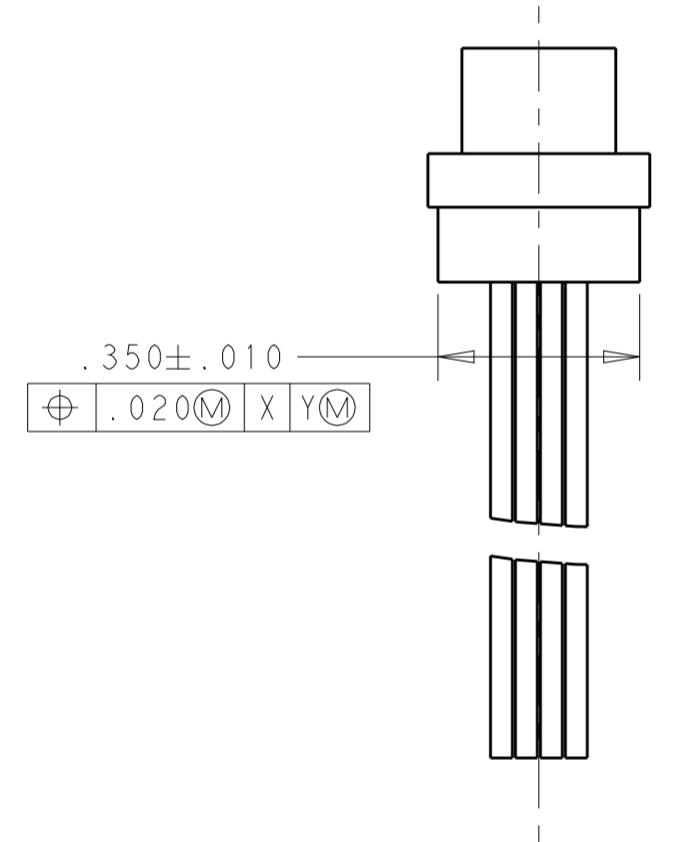
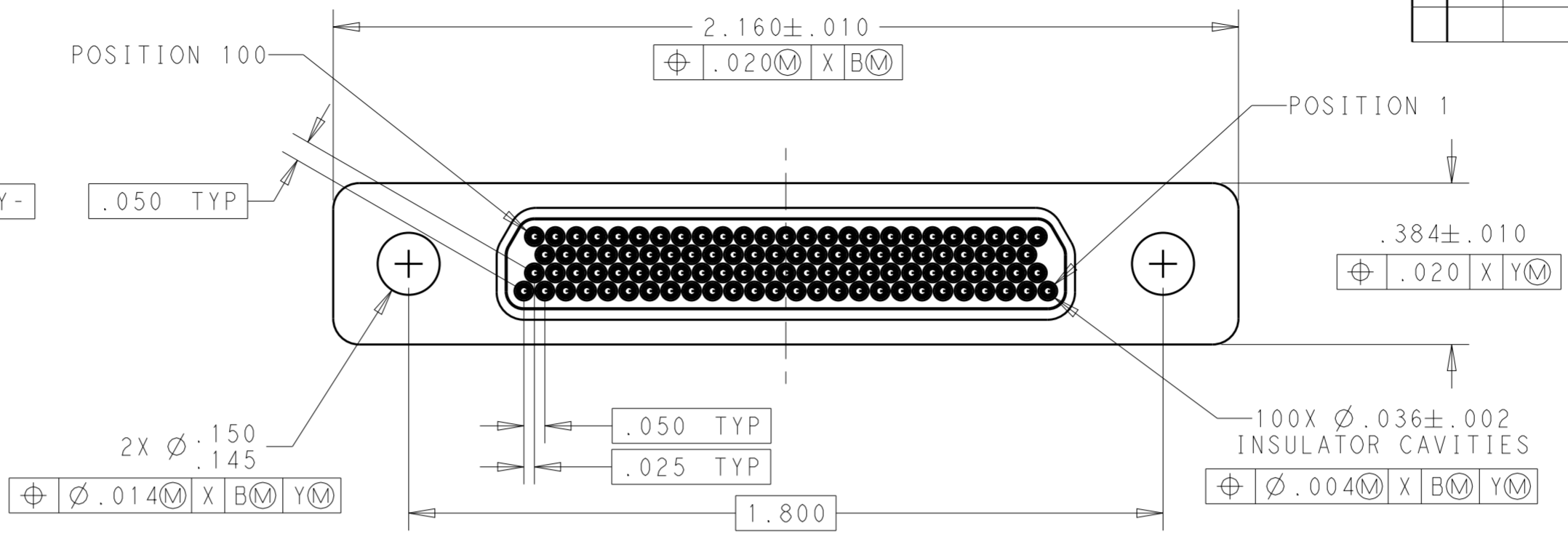
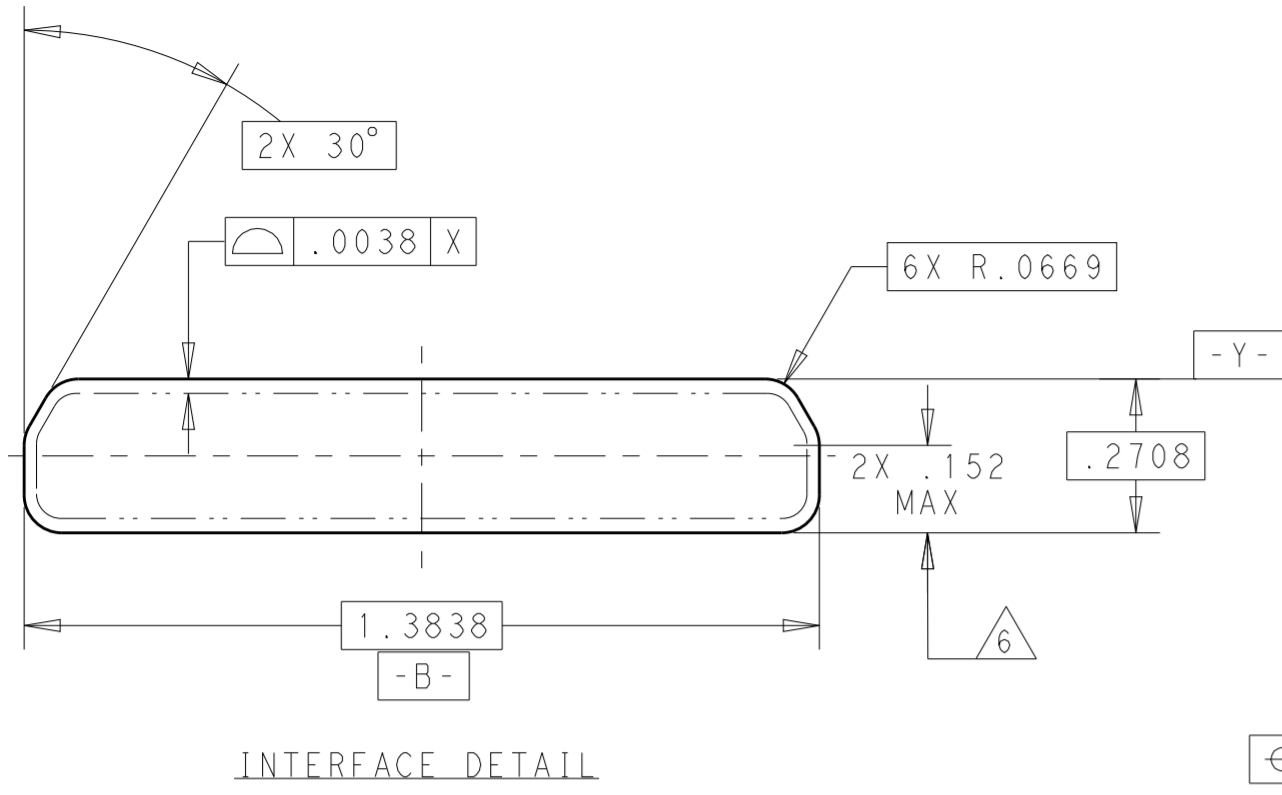

- 1 CONNECTOR SHALL BE MARKED IN ACCORDANCE WITH METHOD 1 OF MIL-STD-1285. MARKING SHALL CONTAIN THE MILITARY PIN, CAGE CODE (OR TE), AND DATE CODE. EXAMPLE: M83513/03-XXXX TE YYWW (WHERE XXXX IS PART OF THE PIN SHOWN IN THE "MIL-DTL-83513" COLUMN OF THE PART NUMBER TABLE, AND YYWW IS THE DATE CODE). TEXT HEIGHT SHALL BE .035 INCH MINIMUM.
- 2 POSITION 1 SHALL BE INDICATED BY AN IDENTIFIABLE MARK, LOCATED APPROXIMATELY AS SHOWN ON THE POSITION 1 SIDE OF THE CONNECTOR FLANGE. THIS MARK SHALL BE INCLUDED AS PART OF THE PART MARKING INFORMATION.
- 3 LENGTH IS SHOWN IN THE "L DIM" COLUMN OF THE PART NUMBER TABLE. LENGTH TOLERANCE IS +1.0/-0.0 FOR INSULATED WIRE TERMINATIONS, AND +0.20/-0.00 FOR UNINSULATED WIRE TERMINATIONS.
- 4 INSULATED WIRE IS SHOWN FOR REFERENCE ONLY. PART MAY BE TERMINATED WITH INSULATED OR UNINSULATED WIRE ACCORDING TO THE PART NUMBER TABLE.
- 5 EPOXY ENCAPSULATION. EPOXY MAY WICK .125 INCH MAX FOR INSULATED WIRE, AND .050 INCH MAX FOR UNINSULATED WIRE.
- 6 THIS DIMENSION IS THE THEORETICAL INTERSECTION OF THE TWO ADJACENT SIDES OF THE INTERFACE.
- 7 ALL DIMENSIONS AND REQUIREMENTS ARE PER MIL-DTL-83513/3

THIS DRAWING IS A CONTROLLED DOCUMENT.		DWN B ROMANCHUK	03SEP2008	TE Connectivity	
DIMENSIONS: IN		CHK M STORRY	03SEP2008		
TOLERANCES UNLESS OTHERWISE SPECIFIED:		APVD		NAME PLUG ASSEMBLY, MICRO-D PER MIL-DTL-83513/03 MCKS SERIES, 100 POSITION	
0 PLC ±		PRODUCT SPEC		SIZE A2	
1 PLC ±		APPLICATION SPEC		CAGE CODE 98278	
2 PLC ±.010		WEIGHT		DRAWING NO G-1532186	
3 PLC ±.005		CUSTOMER DRAWING		RESTRICTED TO	
4 PLC ±		SCALE 1:3		SHEET 1 OF 2	
4 ANGLES ±1°		REV B			
FINISH					
MATERIAL SEE NOTES					

THIS DRAWING IS UNPUBLISHED. RELEASED FOR PUBLICATION 20
 © COPYRIGHT 20 BY - ALL RIGHTS RESERVED.

REVISIONS				
P	LTR	DESCRIPTION	DATE	APVD
		SEE SHEET 1		

TE PART NUMBER	L DIM	MIL-DTL-83513 PIN	MICRODOT P/N	MCKS DESCRIPTION
1532186-1	18	M83513/03-H01N	094-6925-0001	MCKS-N1-B-100P6G1-18.0
1532186-2	36	M83513/03-H02N	094-6925-0002	MCKS-N1-B-100P6G1-36.0
1532186-3	18	M83513/03-H03N	094-6925-0003	MCKS-N1-B-100P6G9-18.0
1532186-4	36	M83513/03-H04N	094-6925-0004	MCKS-N1-B-100P6G9-36.0
1532186-5	18	M83513/03-H09N	094-6925-0009	MCKS-N1-B-100P6Q1-18.0
1532186-6	36	M83513/03-H10N	094-6925-0010	MCKS-N1-B-100P6Q1-36.0
1532186-7	18	M83513/03-H11N	094-6925-0011	MCKS-N1-B-100P6Q9-18.0
1532186-8	36	M83513/03-H12N	094-6925-0012	MCKS-N1-B-100P6Q9-36.0
1532186-9	72	M83513/03-H13N	094-6925-0013	MCKS-N1-B-100P6G1-72.0
1-1532186-0	72	M83513/03-H14N	094-6925-0014	MCKS-N1-B-100P6G9-72.0
1-1532186-1	72	M83513/03-H15N	094-6925-0015	MCKS-N1-B-100P6Q1-72.0
1-1532186-2	72	M83513/03-H16N	094-6925-0016	MCKS-N1-B-100P6Q9-72.0
1-1532186-3	72	M83513/03-H15C	094-6935-0015	MCKS-C2-B-100P6Q1-72.0
1-1532186-4	0.5	M83513/03-H05N	094-6925-0005	MCKS-N1-B-100P5L4-0.5
1-1532186-5	1.0	M83513/03-H06N	094-6925-0006	MCKS-N1-B-100P5L4-1.0
1-1532186-6	0.5	M83513/03-H07N	094-6925-0007	MCKS-N1-B-100P5L5-0.5
1-1532186-7	1.0	M83513/03-H08N	094-6925-0008	MCKS-N1-B-100P5L5-1.0
1-1532186-8	18	M83513/03-H01C	094-6935-0001	MCKS-C2-B-100P6G1-18.0
1-1532186-9	36	M83513/03-H02C	094-6935-0002	MCKS-C2-B-100P6G1-36.0
2-1532186-0	18	M83513/03-H03C	094-6935-0003	MCKS-C2-B-100P6G9-18.0
2-1532186-1	36	M83513/03-H04C	094-6935-0004	MCKS-C2-B-100P6G9-36.0
2-1532186-2	0.5	M83513/03-H05C	094-6935-0005	MCKS-C2-B-100P5L4-0.5
2-1532186-3	1.0	M83513/03-H06C	094-6935-0006	MCKS-C2-B-100P5L4-1.0
2-1532186-4	0.5	M83513/03-H07C	094-6935-0007	MCKS-C2-B-100P5L5-0.5
2-1532186-5	1.0	M83513/03-H08C	094-6935-0008	MCKS-C2-B-100P5L5-1.0
2-1532186-6	18	M83513/03-H09C	094-6935-0009	MCKS-C2-B-100P6Q1-18.0
2-1532186-7	36	M83513/03-H10C	094-6935-0010	MCKS-C2-B-100P6Q1-36.0
2-1532186-8	18	M83513/03-H11C	094-6935-0011	MCKS-C2-B-100P6Q9-18.0
2-1532186-9	36	M83513/03-H12C	094-6935-0012	MCKS-C2-B-100P6Q9-36.0
3-1532186-0	72	M83513/03-H13C	094-6935-0013	MCKS-C2-B-100P6G1-72.0
3-1532186-1	72	M83513/03-H14C	094-6935-0014	MCKS-C2-B-100P6G9-72.0
3-1532186-2	72	M83513/03-H16C	094-6935-0016	MCKS-C2-B-100P6Q9-72.0

TE PART NUMBER	L DIM	MIL-DTL-83513 PIN	MICRODOT P/N	MCKS DESCRIPTION
3-1532186-3	18	M83513/03-H01P	094-6945-0001	MCKS-P1-B-100P6G1-18.0
3-1532186-4	36	M83513/03-H02P	094-6945-0002	MCKS-P1-B-100P6G1-36.0
3-1532186-5	18	M83513/03-H03P	094-6945-0003	MCKS-P1-B-100P6G9-18.0
3-1532186-6	36	M83513/03-H04P	094-6945-0004	MCKS-P1-B-100P6G9-36.0
3-1532186-7	0.5	M83513/03-H05P	094-6945-0005	MCKS-P1-B-100P5L4-0.5
3-1532186-8	1.0	M83513/03-H06P	094-6945-0006	MCKS-P1-B-100P5L4-1.0
3-1532186-9	0.5	M83513/03-H07P	094-6945-0007	MCKS-P1-B-100P5L5-0.5
4-1532186-0	1.0	M83513/03-H08P	094-6945-0008	MCKS-P1-B-100P5L5-1.0
4-1532186-1	18.0	M83513/03-H09P	094-6945-0009	MCKS-P1-B-100P6Q1-18.0
4-1532186-2	36.0	M83513/03-H10P	094-6945-0010	MCKS-P1-B-100P6Q1-36.0
4-1532186-3	18.0	M83513/03-H11P	094-6945-0011	MCKS-P1-B-100P6Q9-18.0
4-1532186-4	36.0	M83513/03-H12P	094-6945-0012	MCKS-P1-B-100P6Q9-36.0
4-1532186-5	72.0	M83513/03-H13P	094-6945-0013	MCKS-P1-B-100P6G1-72.0
4-1532186-6	72.0	M83513/03-H14P	094-6945-0014	MCKS-P1-B-100P6G9-72.0
4-1532186-7	72.0	M83513/03-H15P	094-6945-0015	MCKS-P1-B-100P6Q1-72.0
4-1532186-8	72.0	M83513/03-H16P	094-6945-0016	MCKS-P1-B-100P6Q9-72.0

THIS DRAWING IS A CONTROLLED DOCUMENT.		DWN B ROMANCHUK 03SEP2008	 TE Connectivity	
DIMENSIONS: IN		CHK -		
TOLERANCES UNLESS OTHERWISE SPECIFIED:		NAME PLUG ASSEMBLY, MICRO-D PER MIL-DTL-83513/03 MCKS SERIES, 100 POSITION		RESTRICTED TO -
0 PLC ± 1 PLC ± 2 PLC ±.010 3 PLC ±.005 4 PLC ± ANGLES ±1° FINISH -		PRODUCT SPEC - APPLICATION SPEC - WEIGHT -		
MATERIAL SEE NOTES		SIZE A2		CAGE CODE 98278
		DRAWING NO G-1532186		SCALE 1:3
		CUSTOMER DRAWING		SHEET 2 OF 2
				REV B