

Features

- Low Loss
- Excellent Tx Isolation
- High Rejection

Description

Surface mount, silver (Ag) coated ceramic duplexer. Developed for use in PCS infrastructure and subscriber applications.

Weight: 2.74 grams typical

Material: Filter is composed of a ceramic block coated with Ag and a shield made of nickel silver plated steel.

Filter complies with RoHS standards.

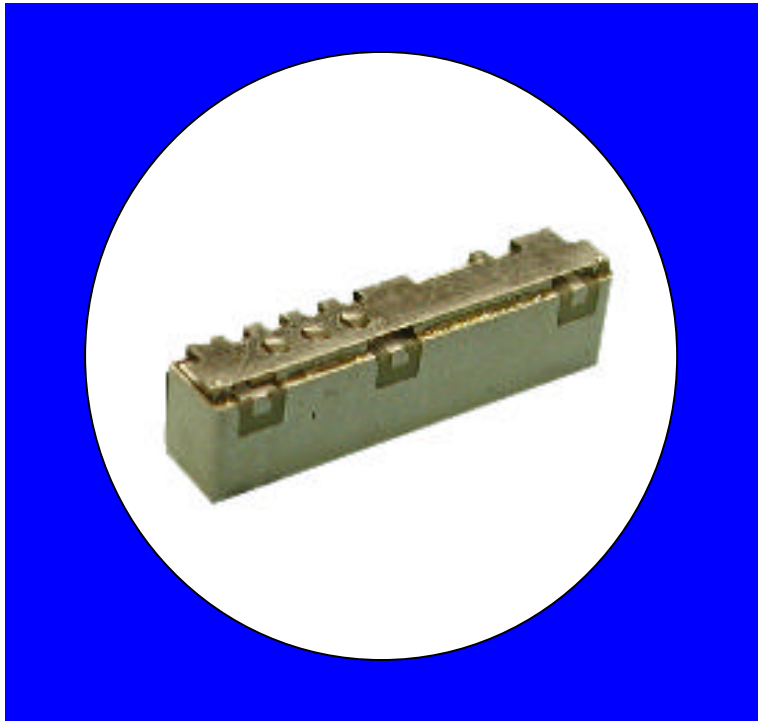

Electrical Specifications

Parameter	Frequency (MHz)	Typical	Spec. @ 25°C	Spec. over -20°C to +70°C
Antenna to TX Response				
Passband Insertion Loss	1850 - 1910	3.2 dB	3.4 dB max	3.7 dB max
Passband Return Loss	1850 - 1910	16.5 dB	11 dB min	10 dB min
Rejection	1930 – 1990	52.5 dB	46 dB min	45 dB min
	2039.8-2099.8	53.5 dB	38 dB min	38 dB min
Antenna to RX Response				
Passband Insertion Loss	1930 - 1990	3.4 dB	3.7 dB max	4.0 dB max
Passband Return Loss	1930 - 1990	14.0 dB	11 dB min	10 dB min
Rejection @ TX band	1850 - 1910	54.5 dB	51 dB min	50 dB min
	2039.8-2099.8	14.0 dB	10 dB min	10 dB min
	2149.6-2209.6	50.0 dB	30 dB min	30 dB min
TX to RX Response				
Rejection @ TX band	1850 - 1910	55.5 dB	54.5 dB min	53.5 dB min
Rejection @ RX band	1930 - 1990	56.0 dB	49 dB min	49 dB min
Power into any port			2 Watt max	

Note: Supplier shall test each filter to the critical electrical specifications of the above table. Any subsequent audits may deviate from in value due to measurement repeatability among different test systems. Such deviations shall not exceed the following limits:

Specification	Allowance
Insertion Loss	0.1 dB
Return Loss	1.0 dB
Stopbands	1.0 dB

*This product is covered by one or more of the following U.S. and foreign patents including: US 4,692,726;US 4,742,562; US 4,800,348;US 4,829,274;US 5,146,193;EP 0573597;DE 0573597;FR 0573597;JP 508149/92;KR 142171;US 5,162,760;US 5,218,329;US 5,250,916;US 5,327,109;US 5,488,335;CA 2114029;FR 9306297;GB 2273393;JP 3205337;KR 115113;CN 93106228.4;US 5,512,866;EP 0706719;DE 0706719;FR 0706719;GB 0706719;CN 95190359.4;US 5,602,518;US 5,721,520;US 5,745,018;EP 0910875;DE 0910875;DK 0910875;FR 0910875;GB 0910875;IE 0910875;JP 505182/98;KR 10-323013;US 5,994,978;US 6,462,629;CN 00810420.4;US 6,559,735;US 6,650,202;US 6,834,429. Other US and foreign patents pending.

CTS Corporation 2006 reserves all copyrights in the layout, design and configuration of the patterns on this product.

Mechanical Drawing

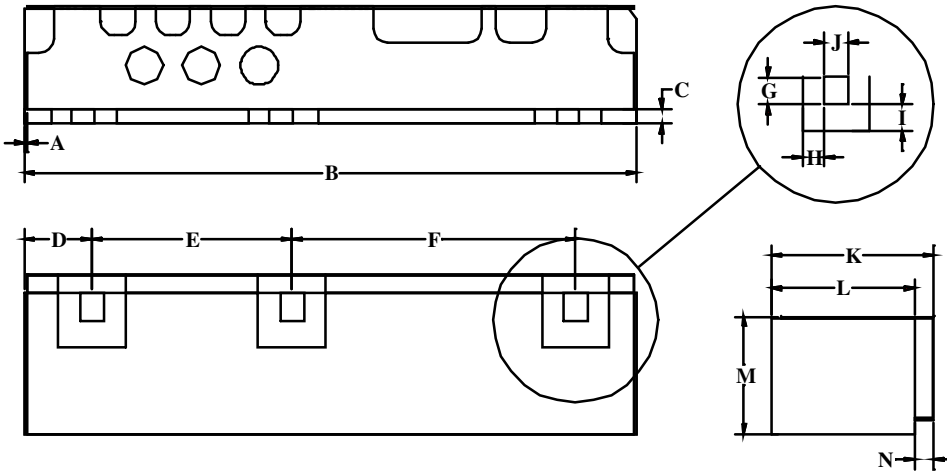

Dim	Nominal (mm)	Tolerance (mm) +/-
A	0.25	0.25
B	22.91	max
C	0.69	0.13
D	2.44	0.25
E	7.43	0.13
F	10.52	0.13
G	1.0	0.13
H	0.8	0.13
I	1.0	0.13
J	0.9	0.13
K	6.53	max
L	5.64	max
M	4.6	max
N	0.84	0.13

Electrical response

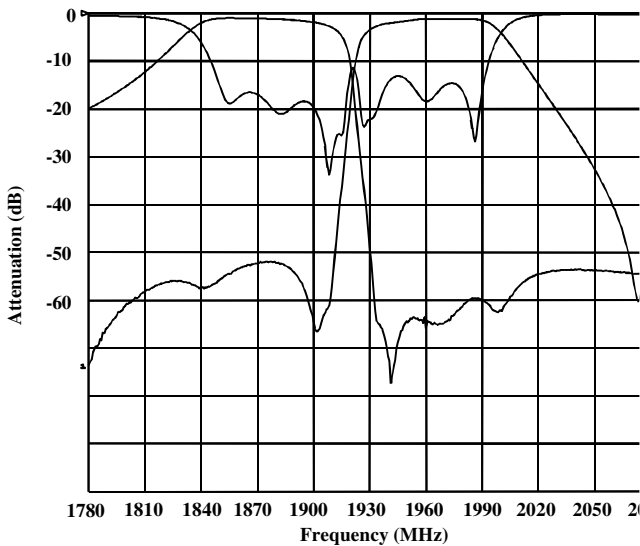

PCB Layout

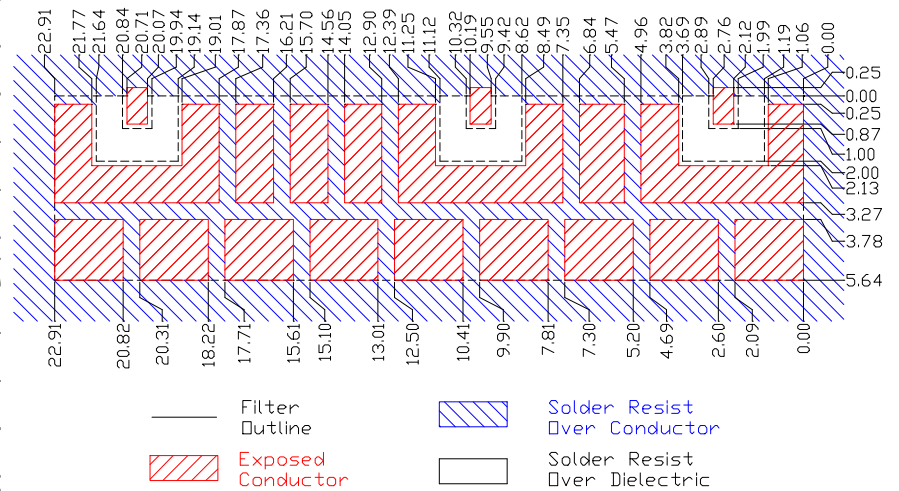

Packaging and Marking

DIMENSION	UNITS	SPECIFICATION
REEL DIAMETER	mm	330
REEL WEIGHT	kg	2.2
REEL QUANTITY	ea.	500

