

RECOMMENDED PCB LAYOUT
FOR DIFFERENTIAL APPLICATIONS
COMPONENT SIDE
(TWO ADJACENT FOOTPRINTS SHOWN)
NOTES 8 & 12

SCALE 10:1

spec ref	---	dr	Lin-Soo Ngwe	2012/1/29	projection	MM	size	A2	scale	8:1											
tolerance std	ASME Y14.5M	eng	Terry Luo	2020/09/08			ecn no	ELX-DG-38252-1													
TOLERANCES UNLESS OTHERWISE SPECIFIED		chr	-	appr			Heaven Cen	2020/09/17	rel level	Released											
surface	<table border="1"> <tr> <td>linear</td> <td>0.X</td> <td>±.3</td> </tr> <tr> <td></td> <td>0.XX</td> <td>±.15</td> </tr> <tr> <td></td> <td>0.XXX</td> <td>±.050</td> </tr> <tr> <td>angular</td> <td>0°</td> <td>±2°</td> </tr> </table>	linear	0.X	±.3		0.XX	±.15		0.XXX	±.050	angular	0°	±2°			title AirMax VS2 R.A. HEADER 3 PAIR 54 POS 2MM 6 COL, GXT+		product family -	cat. no. -	Product - Customer Drw	sheet 2 of 3
linear	0.X	±.3																			
	0.XX	±.15																			
	0.XXX	±.050																			
angular	0°	±2°																			
							Amphenol FCI title AirMax VS2 R.A. HEADER 3 PAIR 54 POS 2MM 6 COL, GXT+	product family -	cat. no. -	Product - Customer Drw	sheet 2 of 3										

PRODUCT NUMBER	PRESS-FIT TAIL PLATING TYPE	SHORT DETECT CONTACT	REMARKS
10123543-101	TIN/LEAD ALLOY OVER NICKEL	NO	1-SIDED PLATING (CUSTOMER SPECIAL)
10123543-101LF	TIN OVER NICKEL (LEAD FREE)		
10123543-111	TIN/LEAD ALLOY OVER NICKEL	YES (SEE NOTE 13)	
10123543-111LF	TIN OVER NICKEL (LEAD FREE)		
10123543-102	TIN/LEAD ALLOY OVER NICKEL	NO	2-SIDED PLATING
10123543-102LF	TIN OVER NICKEL (LEAD FREE)		
10123543-112	TIN/LEAD ALLOY OVER NICKEL	YES (SEE NOTE 13)	
10123543-112LF	TIN OVER NICKEL (LEAD FREE)		

1 - CONNECTOR MATERIALS:
HOUSING: HIGH TEMP THERMOPLASTIC, NATURAL, UL94-V0
IMLA PLASTIC: HIGH TEMP THERMOPLASTIC, BLACK, UL94-V0
CONTACT: COPPER ALLOY
ORGANIZER: HIGH TEMP THERMOPLASTIC, NATURAL, UL94-V0

2 - CONTACT PLATING:
SEPARABLE INTERFACE:
PERFORMANCE-BASED PLATING, QUALIFIED TO MEET THE REQUIREMENTS OF FCI PRODUCT SPECIFICATION GS-12-0956 INCLUDING TELCORDIA GR-1217-CORE (NOVEMBER 1995) CENTRAL OFFICE TEST SEQUENCE

PRESS-FIT TAILS: SEE TABLE

3 - PRODUCT SPECIFICATION: GS-12-0956

4 - APPLICATION SPECIFICATION: GS-20-0305

5 - PRODUCT MARKING, (PROTOTYPE, PART NUMBER & LOT CODE), ON THIS SURFACE.

6 - POSITIONS "F" OF ODD NUMBERED COLUMNS AND POSITIONS "G" OF EVEN NUMBERED COLUMNS CORRESPOND TO EARLY MATE HEADER PINS.

7 - CONNECTOR OUTLINE MAY BE SCREEN PRINTED ONTO CUSTOMER PCB TO BE USED AS A GUIDE FOR CONNECTOR PLACEMENT.

8 - REFER TO CUSTOMER DRAWING 10104444 FOR INFORMATION ON PCB HOLE DIAMETERS AND PLATING OPTIONS

9 - LEAD FREE PRODUCT MEETS THE EUROPEAN UNION DIRECTIVES & OTHER COUNTRY REGULATIONS AS DESCRIBED IN GS-22-008

10 - PACKAGING MEETS GS-14-920 LEAD FREE LABELING SPECIFICATION.

11 - GROUND CONTACTS (C, F, & I IN ODD COLUMNS AND A, D, & G IN EVEN COLUMNS) REQUIRE (Ø0.500) FINISHED HOLES. SIGNAL LOCATIONS REQUIRE (Ø0.500) FINISHED HOLES

12 - THESE OUTER VIAS (J) ARE OPTIONAL. WHILE NO CONNECTOR EONS ARE PRESSED INTO THESE HOLES WE RECOMMEND (Ø0.500) FINISHED HOLES AT THESE LOCATIONS TO PROVIDE GROUND SYMMETRY THROUGH THE PCB.

13 - MATING PIN E4 HAS 0.5mm LESS NOMINAL WIPE THAN THE SHORTEST PIN.

14. A  SYMBOL WILL BE NEXT TO ANY DIMENSION, VIEW, OR NOTE, WHICH HAS BEEN MODIFIED WITH THE CURRENT DRAWING REVISION.

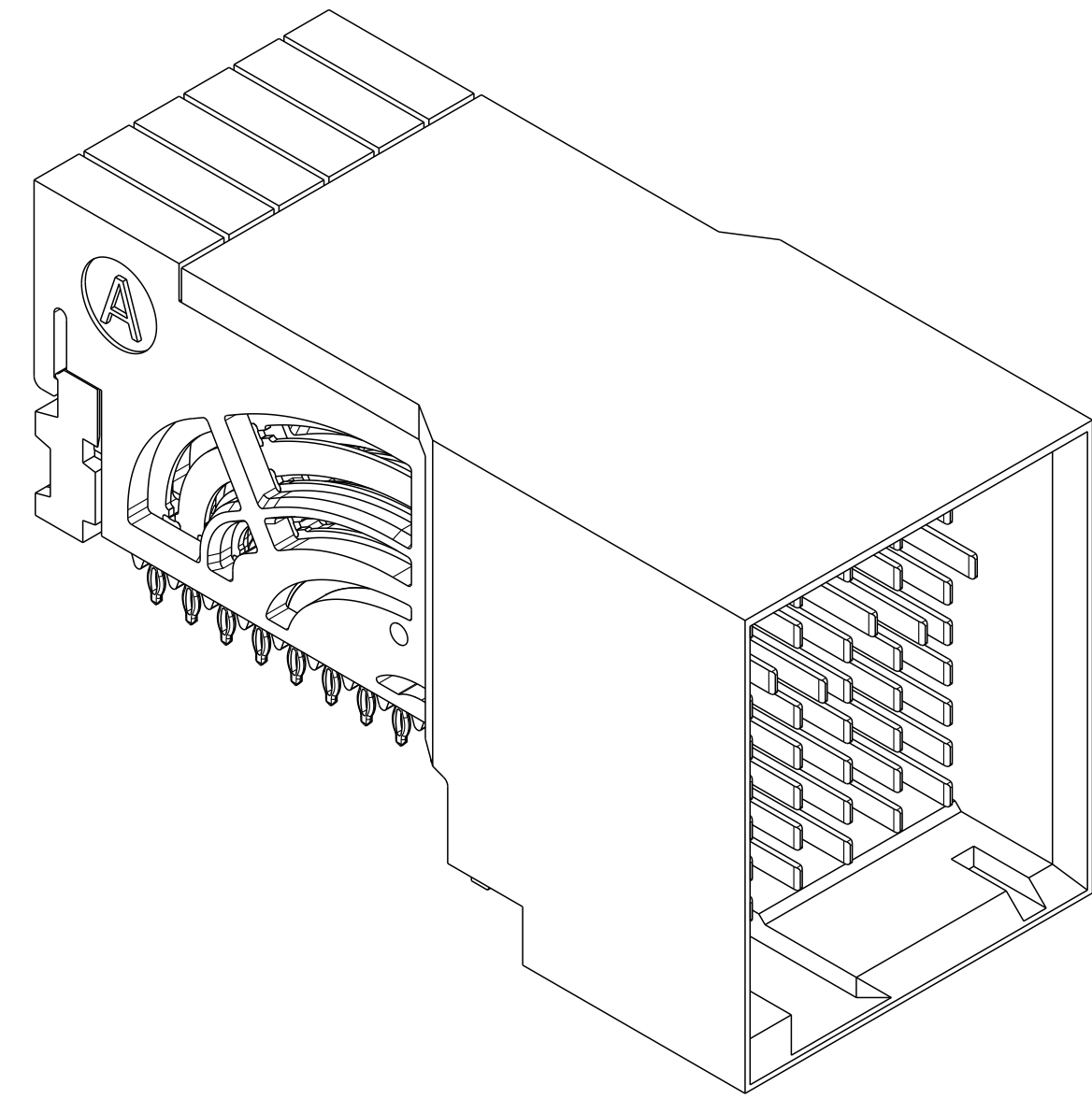

10123543-101 OR -101LF

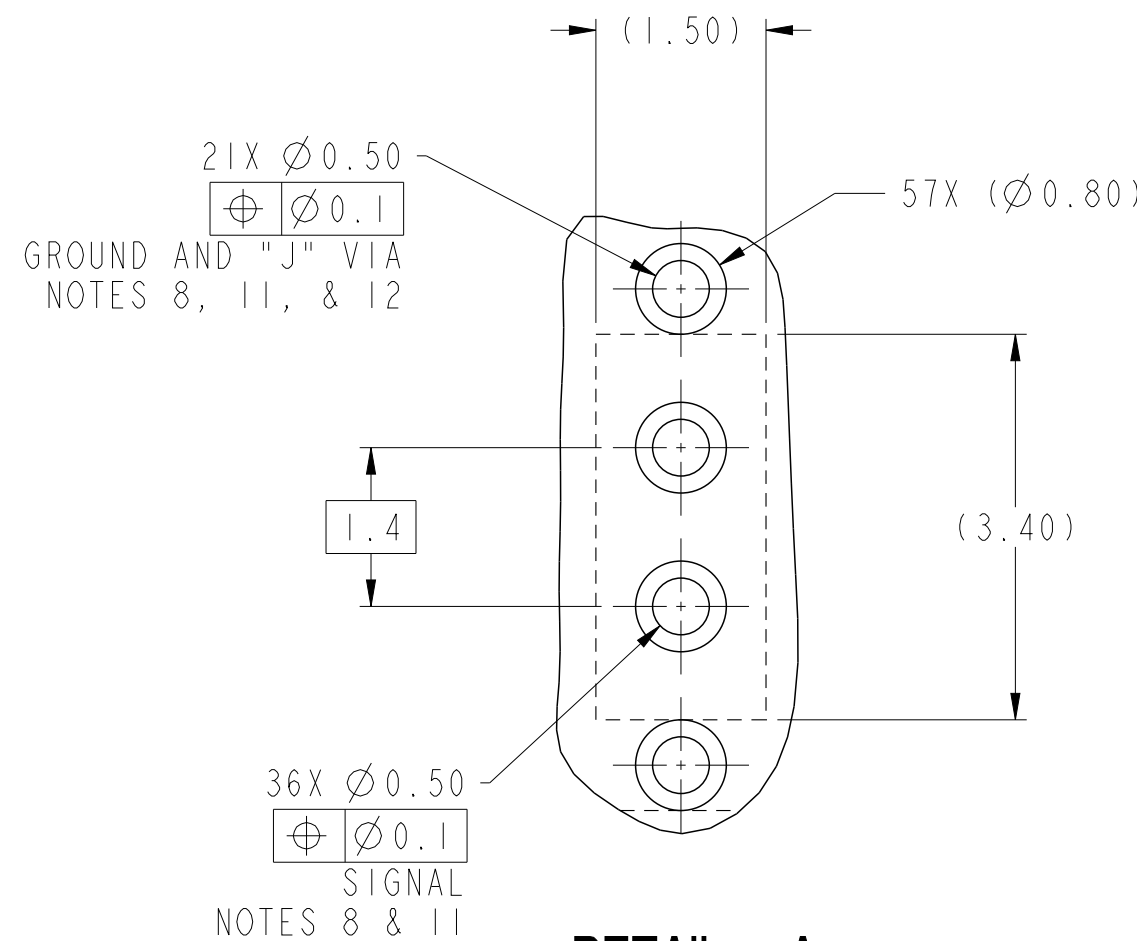

DETAIL A
SCALE 15:1

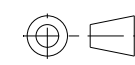
spec ref	---	dr	Lin-Soe Ngwe	2012/1/29	projection	MM	size	A2	scale	5:1			
tolerance std	ASME Y14.5M	eng	Terry Luo	2020/09/08		←	ecn no	ELX-DG-38252-1	rel level	Released			
TOLERANCES UNLESS OTHERWISE SPECIFIED		chr	-	apppr							Heaven Cen	2020/09/17	
surface	linear	0.X	±.3	Amphenol FCI		title		AirMax VS2 R.A. HEADER		dwg no	10123543	rev	E
		0.XX	±.15										
		0.XXX	±.050										
	angular	0°	±2°	cat. no.		Product - Customer Drw		sheet 3 of 3					

Amphenol FCI

© 2016 AFCI