

THIS DRAWING IS UNPUBLISHED. RELEASED FOR PUBLICATION
 BY AMP INCORPORATED. ALL RIGHTS RESERVED.

| Loc | | DIST | | REVISIONS | | | |
|-----|-----|-------------|----------------------|-----------|------|----|--|
| P | LTR | DESCRIPTION | DATE | DWN | APVD | | |
| DF | SO | A | REV PER 0600-6359-97 | 10-15-97 | TT | SG | |

1. THIS RECEPTACLE IS HERMETICALLY SEALED.
2. THIS RECEPTACLE MATES WITH LEAD NO 863124.
3. RECOMMENDED MAX PANEL THICKNESS IS .175.

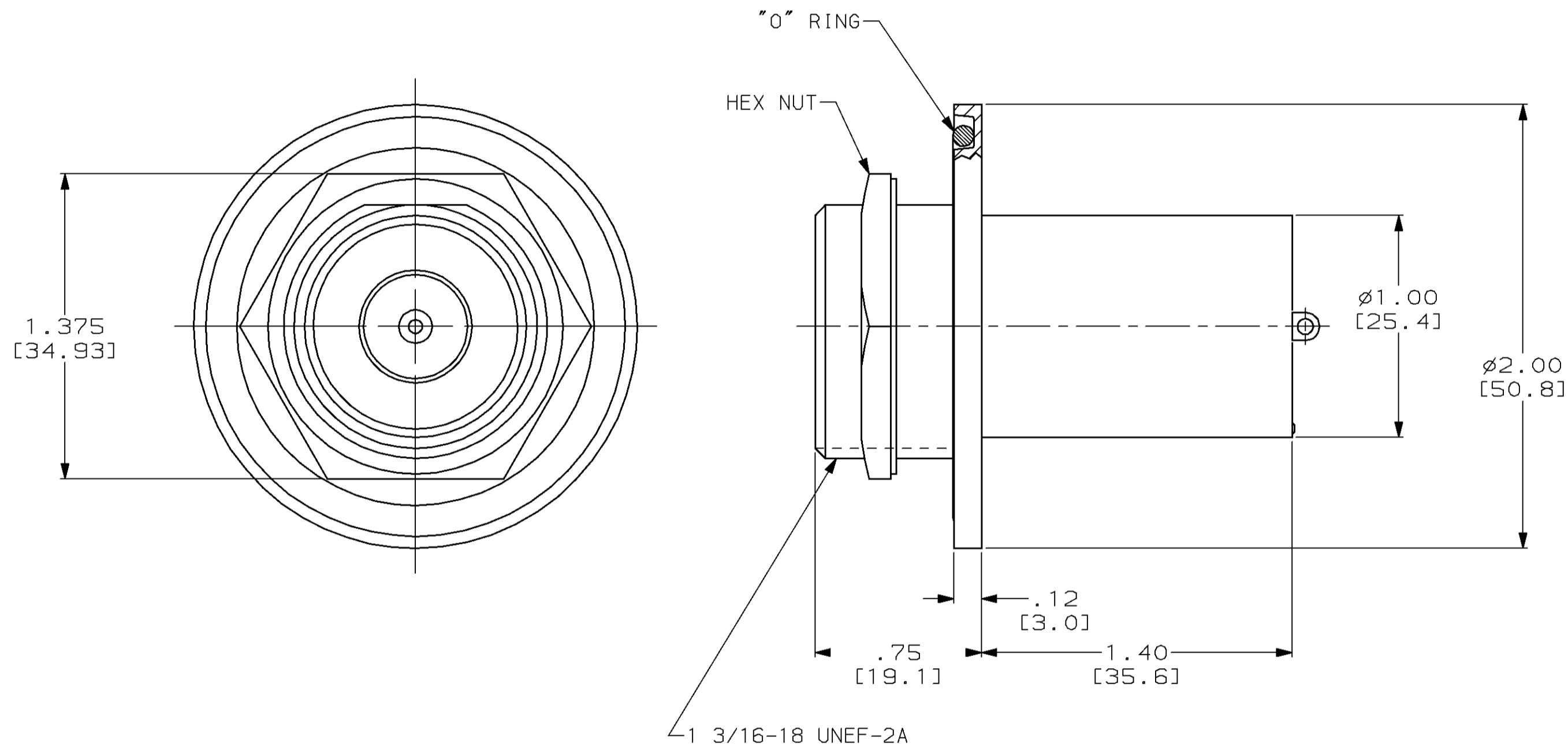

863125-1
 PART NUMBER

| | | | | |
|--|--------------------|-----------------------|-----------|--|
| THIS DRAWING IS A CONTROLLED DOCUMENT. | | DWN T. THOMPSON | 10-15-97 | AMP AMP Incorporated Harrisburg, PA 17105-3608 |
| DIMENSIONS: IN [MM] | | CHK S. GLATFELTER | 01-28-98 | |
| TOLERANCES UNLESS OTHERWISE SPECIFIED: | | APVD S. GLATFELTER | 01-28-98 | NAME |
| 0 PLC ±- | 1 PLC ±- | PRODUCT SPEC | | RECEPTACLE, VERSATILE RUGGEDIZED, LGH-4 |
| 2 PLC ±.02 [0.51] | 3 PLC ±.005 [0.13] | APPLICATION SPEC | | SIZE CAGE CODE DRAWING NO |
| 4 PLC ±- | ANGLES ±- | FINISH - | | A2 00779 C-863125 |
| MATERIAL - | FINISH - | WEIGHT - | | RESTRICTED TO |
| CUSTOMER DRAWING | | | SCALE 2:1 | SHEET 1 OF 1 |

863125

A