

Description

The AP2132B series are positive voltage regulator ICs fabricated by CMOS process. The ICs consist of a voltage reference, an error amplifier, a power transistor, a resistor network for setting output voltage, a current limit circuit for current protection, and a chip enable circuit.

The AP2132B series have features of large current, low dropout voltage, high output voltage accuracy, low input voltage. The AP2132B provides a power good (PG) signal to indicate if the voltage level of V_{OUT} reaches 92% of its rating value. And it operates with V_{IN} as low as 1.4V and V_{CTRL} voltage 5V with output voltage programmable as low as 0.8V.

The AP2132B are available in 1.2V, 1.5V, 1.8V, 2.5V fixed output voltage versions and adjustable output voltage version. The fixed versions integrate the adjust resistors. It is also available in an adjustable version, which can set the output voltage with external resistor. If the pin of adjustable output voltage is to ground, it will switch to fixed output voltage.

AP2132B series are available in PSOP-8 package.

Features

- Adjustable Output: 0.8V to 3.0V
- Low Dropout Voltage: 300mV@ $I_{OUT} = 2A$, $V_{OUT} = 1.2V$
- Over Current and Over Temperature Protection
- Enable Pin
- PSOP-8 Package with Thermal Pad
- Maximum Output Current: 2A
- High Output Voltage Accuracy: 2%
- V_{OUT} Power Good Signal
- Excellent Line/Load Regulation

Pin Assignments

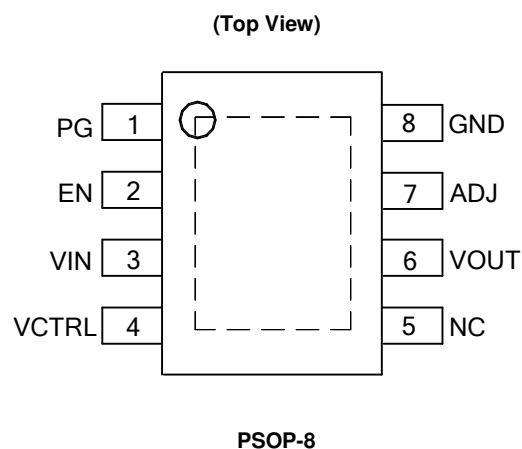

Applications

- Notebook

Typical Applications Circuit

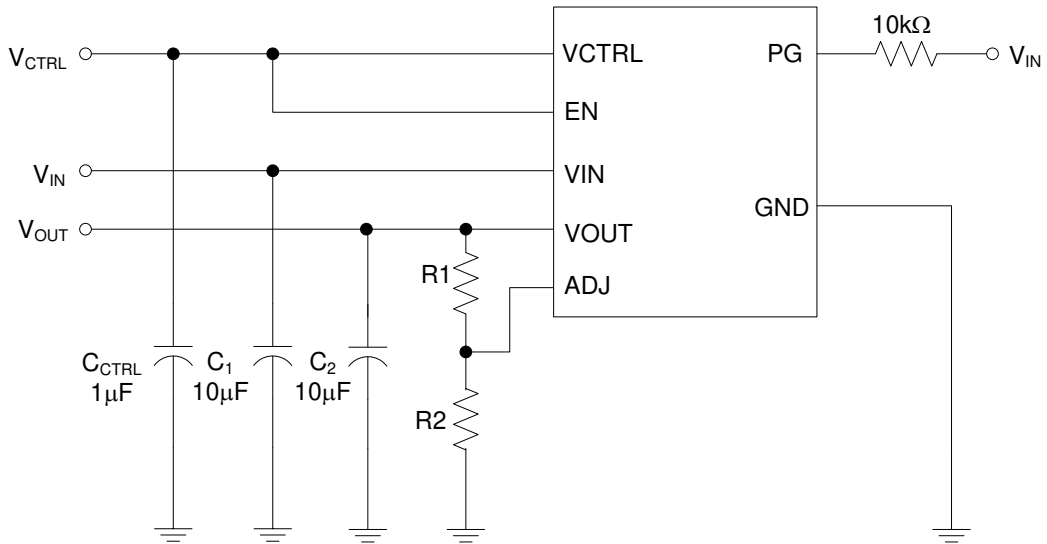

$$V_{OUT} = \frac{0.8 (R1+R2)}{R2}$$

For Adjustable Version

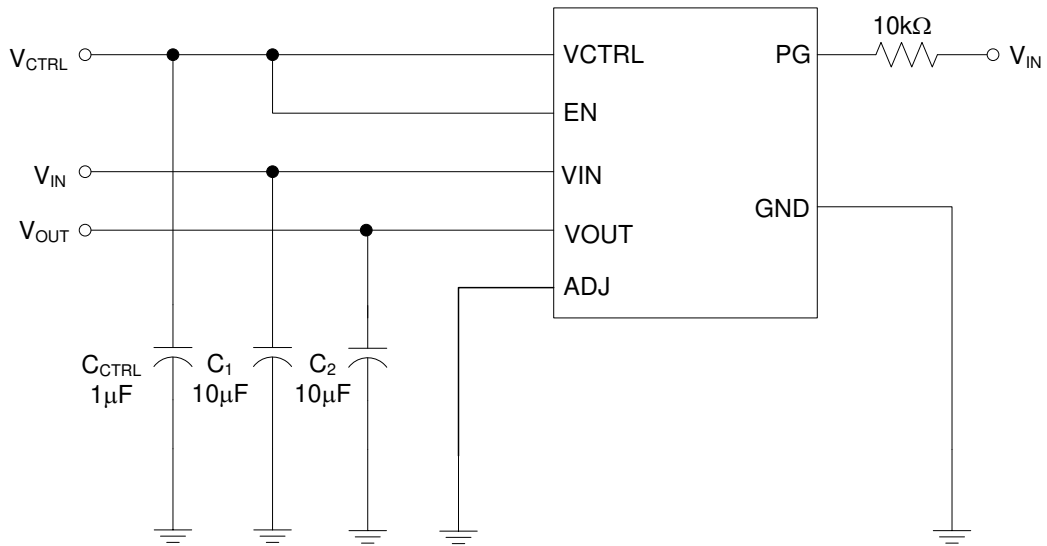

For Fixed Version

Pin Descriptions

Pin Number	Pin Name	Function
1	PG	Assert high once V_{OUT} reaches 92% of its rating voltage
2	EN	Enable input
3	VIN	Input voltage
4	VCTRL	Input voltage for controlling circuit
5	NC	Not connected
6	VOUT	Regulated output voltage
7	ADJ	Adjust output: when connected to ground, the output voltage is set by internal resistors; when external feedback resistors are connected, the output voltage will be $V_{OUT} = 0.8(R1+R2)/R2$.
8	GND	Ground

Functional Block Diagram

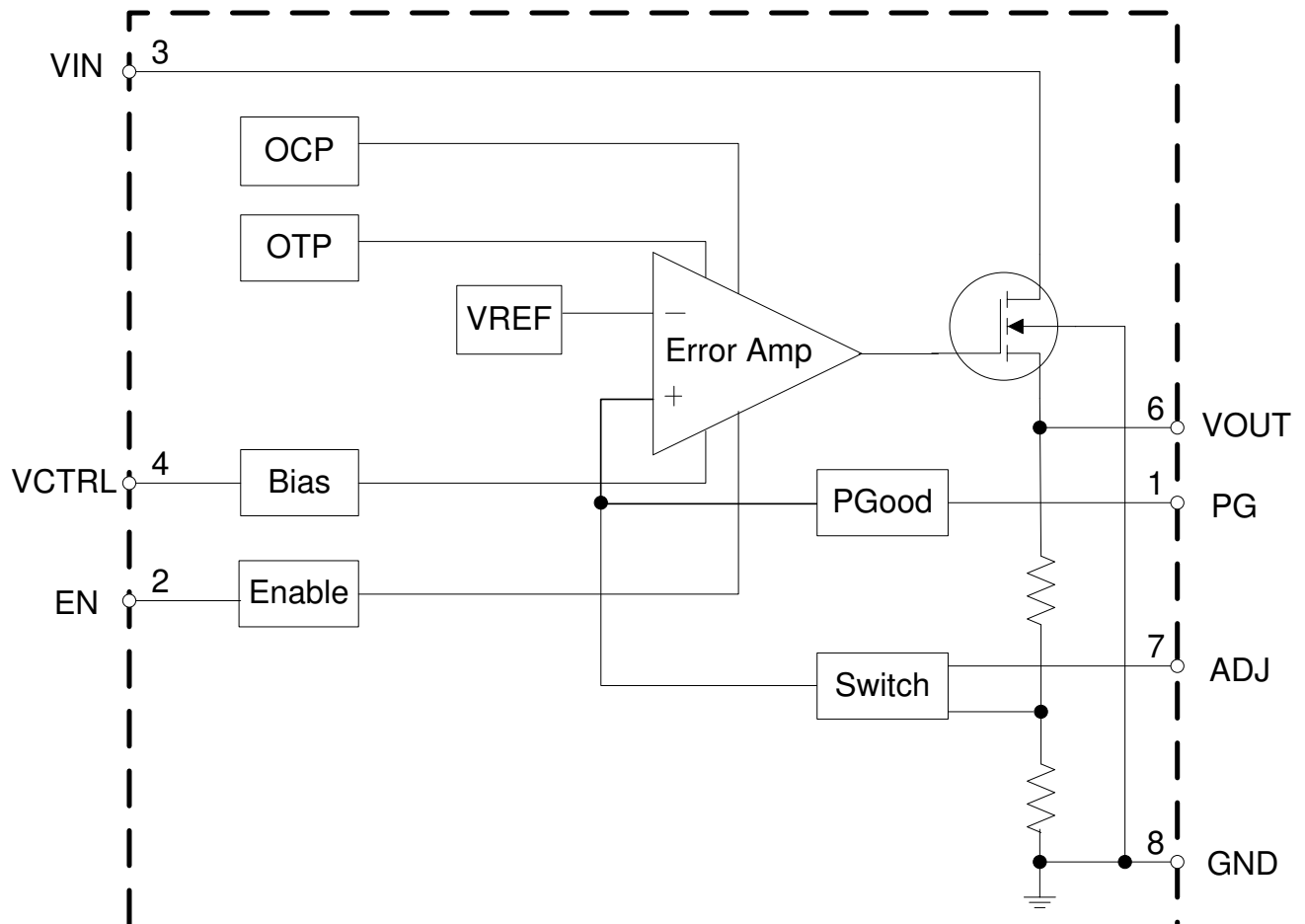

Absolute Maximum Ratings (Note 1)

Symbol	Parameter	Rating	Unit
V_{IN}	Input Voltage	6.0	V
V_{CTRL}	Input Voltage for Controlling Circuit		
V_{EN}	Enable Input Voltage	-0.3 to 6.0	V
I_{OUT}	Output Current	2.5	A
θ_{JA}	Thermal Resistance (Note 2)	53	°C/W
T_J	Operating Junction Temperature	+150	°C
T_{STG}	Storage Temperature Range	-65 to +150	°C
T_{LEAD}	Lead Temperature (Soldering, 10sec)	+260	°C
—	ESD (Machine Model)	200	V
—	ESD (Human Body Model)	2000	V

- Notes:
1. Stresses greater than those listed under "Absolute Maximum Ratings" may cause permanent damage to the device. These are stress ratings only, and functional operation of the device at these or any other conditions beyond those indicated under "Recommended Operating Conditions" is not implied. Exposure to "Absolute Maximum Ratings" for extended periods may affect device reliability.
 2. θ_{JA} is measured with the component mounted on 2-Layer FR-4 PCB board with 1.0cm*1.0cm thermal sink pad in free air.

Recommended Operating Conditions

Symbol	Parameter	Min	Max	Unit
V_{IN}	Input Voltage	1.4	5.5	V
V_{CTRL}	Input Voltage for Controlling Circuit	4.5	5.5	V
T_A	Operating Ambient Temperature Range	-40	+85	°C

Electrical Characteristics (@ $V_{IN} = V_{OUT} + 0.5V$, $V_{CTRL} = V_{EN} = 5V$, $T_A = +25^\circ C$, $C_{IN} = C_{OUT} = 10\mu F$, $C_{CTRL} = 1\mu F$, $I_{OUT} = 10mA$, unless otherwise specified.)

Symbol	Parameter	Conditions	Min	Typ	Max	Unit	
V_{OUT}	Output Voltage	$V_{IN} = V_{OUT} + 0.5V$, $I_{OUT} = 10mA$	$V_{OUT} \times 98\%$	—	$V_{OUT} \times 102\%$	V	
V_{IN}	Input Voltage	—	1.4	—	5.5	V	
I_{LIMIT}	Current Limit	$V_{IN} - V_{OUT} = 1V$	3	—	—	A	
V_{RLOAD}	Load Regulation	$V_{IN} = V_{OUT} + 0.5V$, $10mA \leq I_{OUT} \leq 2A$	—	10	—	mV	
V_{RLINE}	Line Regulation	$V_{OUT} + 0.5V \leq V_{IN} \leq 5V$, $I_{OUT} = 10mA$	—	2	—	mV	
V_{DROP}	Dropout Voltage	$I_{OUT} = 500mA$	—	80	120	mV	
		$I_{OUT} = 1A$	—	150	200	mV	
		$I_{OUT} = 2A$	—	300	450	mV	
I_{SUPPLY}	Supply Current	$V_{IN} = V_{OUT} + 0.5V$, $I_{OUT} = 0mA$	—	300	—	μA	
I_{CTRLH}	V_{CTRL} Current	$V_{IN} = V_{OUT} + 0.5V$, $V_{CTRL} = V_{EN} = 5V$	—	250	500	μA	
$I_{CTRL L}$		$V_{IN} = V_{OUT} + 0.5V$, $V_{CTRL} = 5V$, $V_{EN} = 0V$	—	0.1	1.0	μA	
PSRR	Power Supply Rejection Ratio	Ripple 0.5Vp-p, $V_{IN} = V_{OUT} + 1V$	f = 100Hz	—	60	—	dB
			f = 1kHz	—	60	—	dB
$\frac{\Delta V_{OUT}}{V_{OUT} \times \Delta T}$	Output Voltage Temperature Coefficient	$I_{OUT} = 10mA$, $-40^\circ C \leq T_A \leq +85^\circ C$	—	± 100	—	ppm/ $^\circ C$	
I_{SHORT}	Short Circuit Current	—	—	0.3	0.5	A	
V_{REF}	Reference Voltage	Adjust Short to V_{OUT}	0.784	0.8	0.816	V	
—	Enable "High" Voltage	Enable Input Voltage "High"	1.2	—	—	V	
—	Enable "Low" Voltage	Enable Input Voltage "Low"	—	—	0.4	V	
OTSD	Thermal Shutdown	—	—	+165	—	$^\circ C$	
—	Thermal Shutdown Hysteresis	—	—	+20	—	$^\circ C$	
V_{THPG}	V_{OUT} Power Good Voltage	—	—	92	—	%	
—	V_{PG} Hysteresis	—	—	7	—	%	
—	Adjust Pin Threshold	—	—	200	—	mV	
θ_{JC}	Thermal Resistance (Junction to Case)	PSOP-8	—	29	—	$^\circ C/W$	

Performance Characteristics

Supply Current vs. Output Current

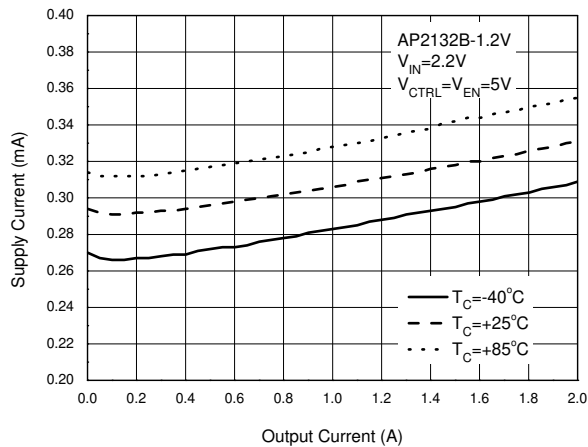

Supply Current vs. Case Temperature

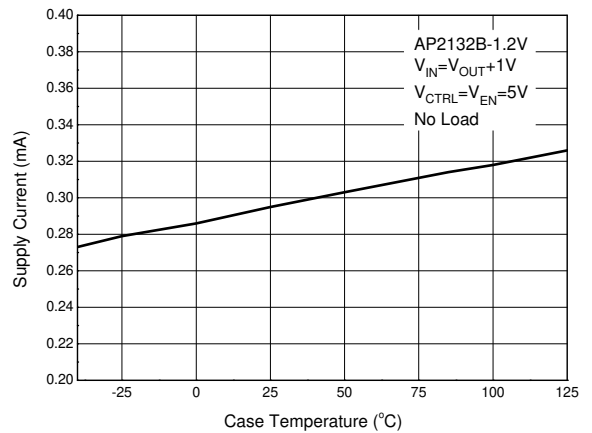

Enable High/Low Voltage vs. Case Temperature

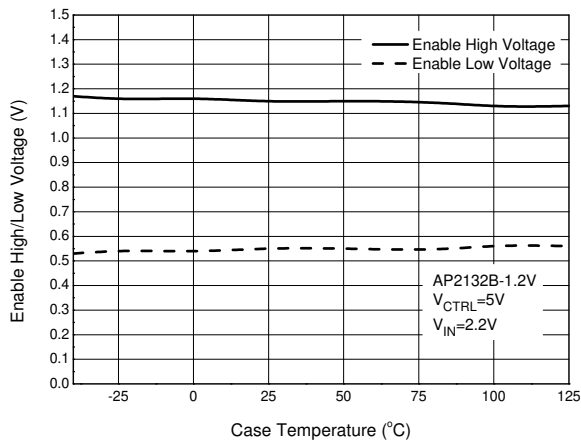

Supply Current vs. Input Voltage

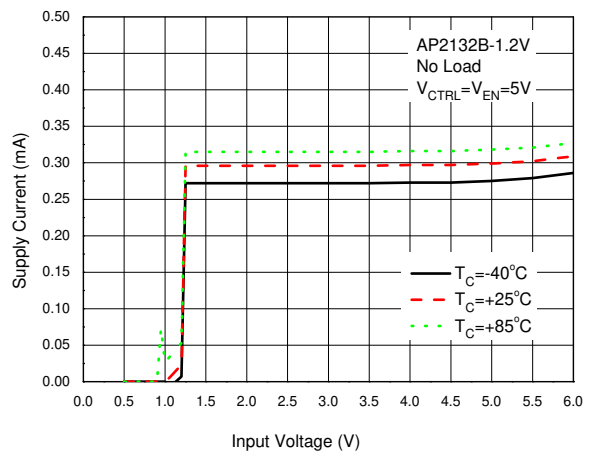

Output Voltage vs. Case Temperature

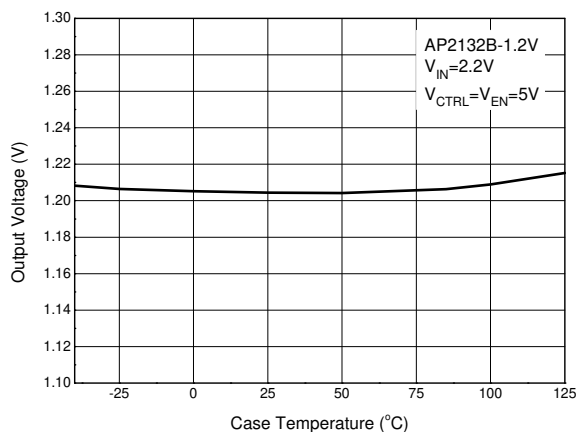

Output Voltage vs. Output Current

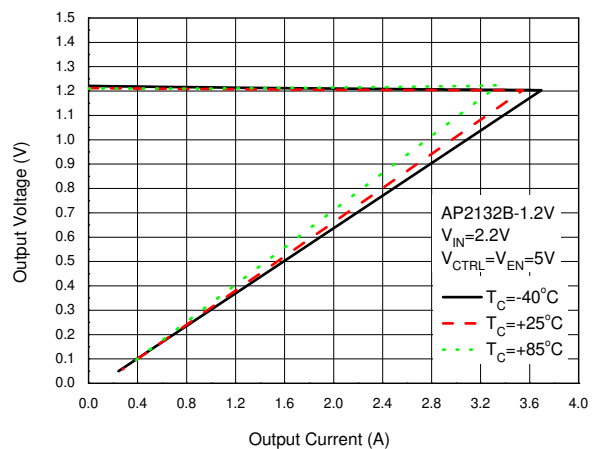

Performance Characteristics (Cont.)

Output Voltage vs. Input Voltage

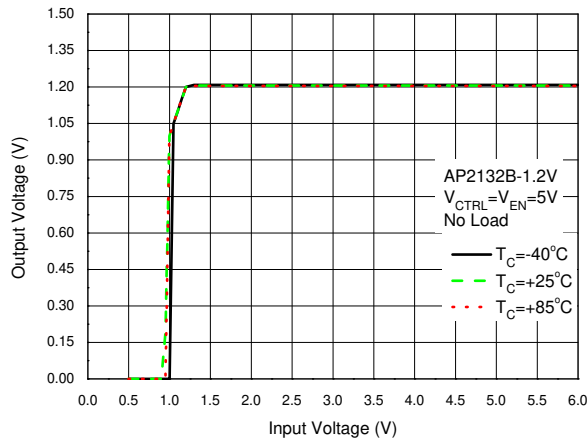

Dropout Voltage vs. Output Current

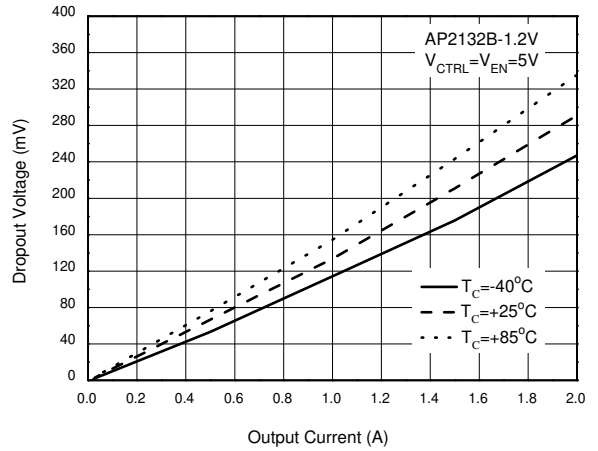

Dropout Voltage vs. Case Temperature

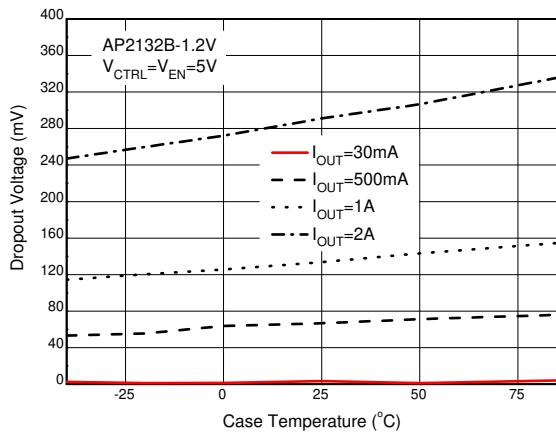

Short Current vs. Case Temperature

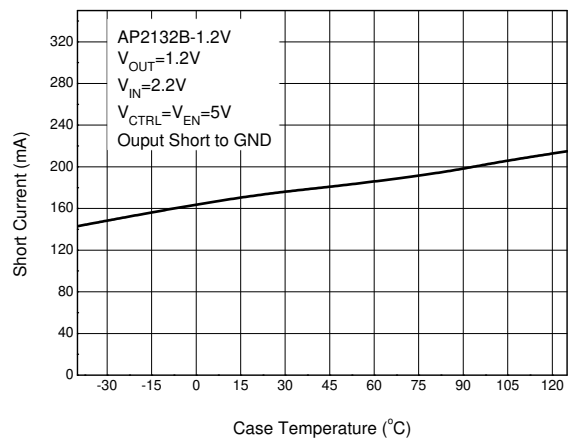

PSRR vs. Frequency

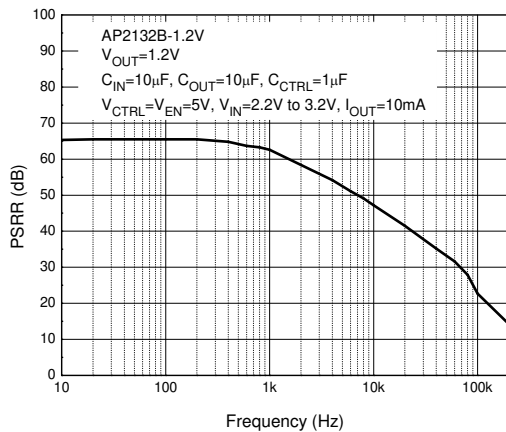

V_{IN} Start up Waveform
(V_{CTRL}=V_{EN}=5V, V_{IN}=0 to 2.2V, No Load)

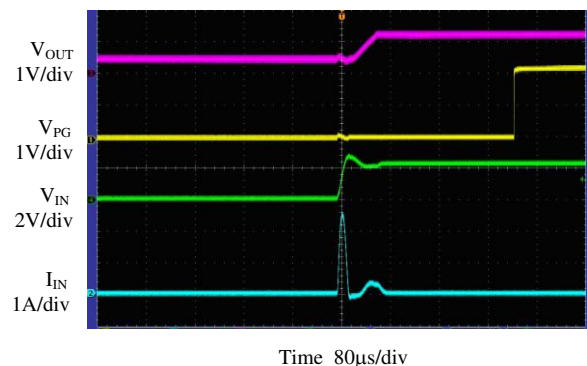

Performance Characteristics (Cont.)

V_{EN} Start up Waveform
(V_{CTRL}=5V, V_{EN}=0 to 5V, V_{IN}=2.2V, No Load)

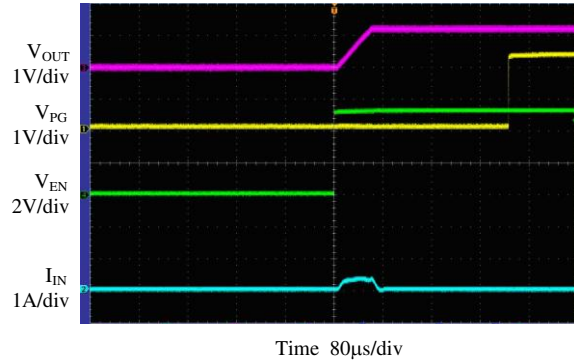

V_{CTRL} Start up and Shut down Waveform
(V_{CTRL}=0 to 5V, V_{EN}=5V, V_{IN}=2.2V, No Load)

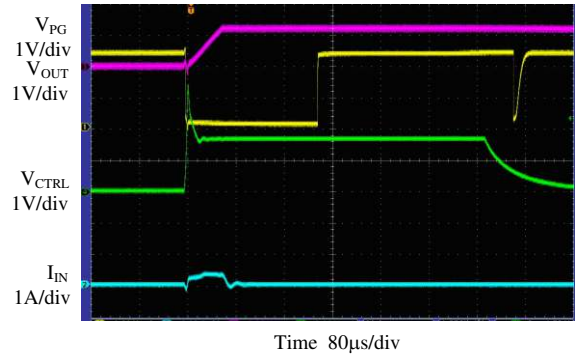

Load Transient
(V_{CTRL}=V_{EN}=5V, V_{IN}=2.2V, I_{OUT}=0 to 2A)

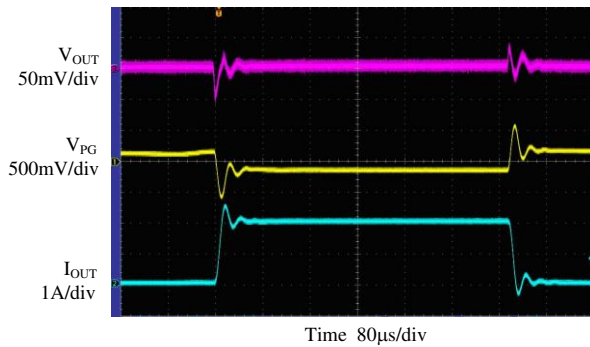

Line Transient
(V_{CTRL}=V_{EN}=5V, C_{IN}=C_{CTRL}=1µF, C_{OUT}=10µF, V_{IN}=2.2V to 3.2V, I_{OUT}=10mA)

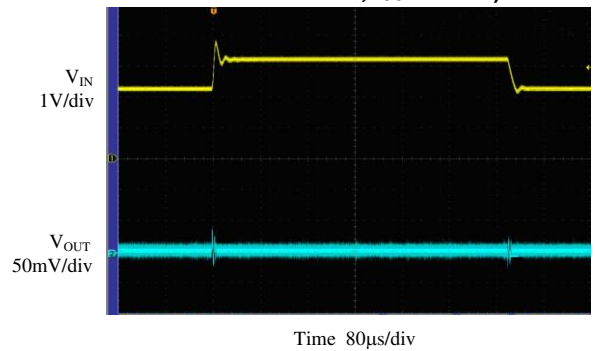

Ordering Information

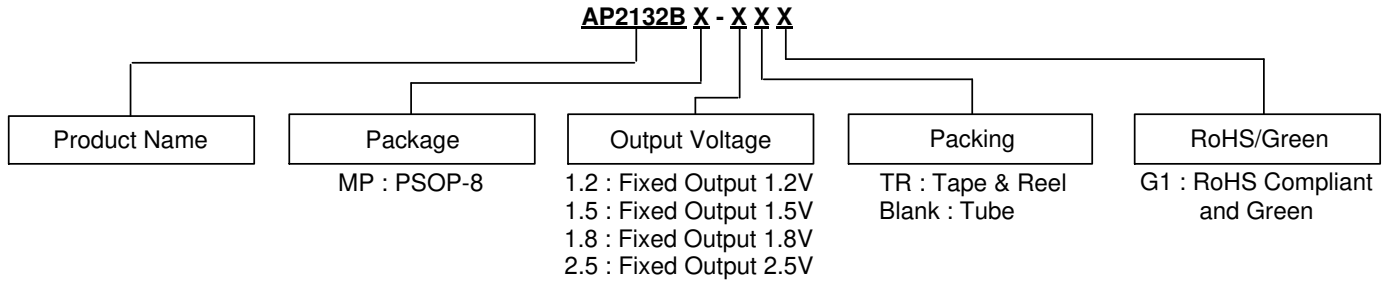

Package	Temperature Range	Version Description	Part Number	Marking ID	Packing
PSOP-8	-40 to +85°C	Each fixed output version integrates ADJ version	AP2132BMP-1.2G1	2132B-1.2G1	Tube
			AP2132BMP-1.2TRG1	2132B-1.2G1	Tape & Reel
			AP2132BMP-1.5G1	2132B-1.5G1	Tube
			AP2132BMP-1.5TRG1	2132B-1.5G1	Tape & Reel
			AP2132BMP-1.8G1	2132B-1.8G1	Tube
			AP2132BMP-1.8TRG1	2132B-1.8G1	Tape & Reel
			AP2132BMP-2.5G1	2132B-2.5G1	Tube
			AP2132BMP-2.5TRG1	2132B-2.5G1	Tape & Reel

Package Outline Dimensions (All dimensions in mm(inch).)

(1) Package Type: PSOP-8

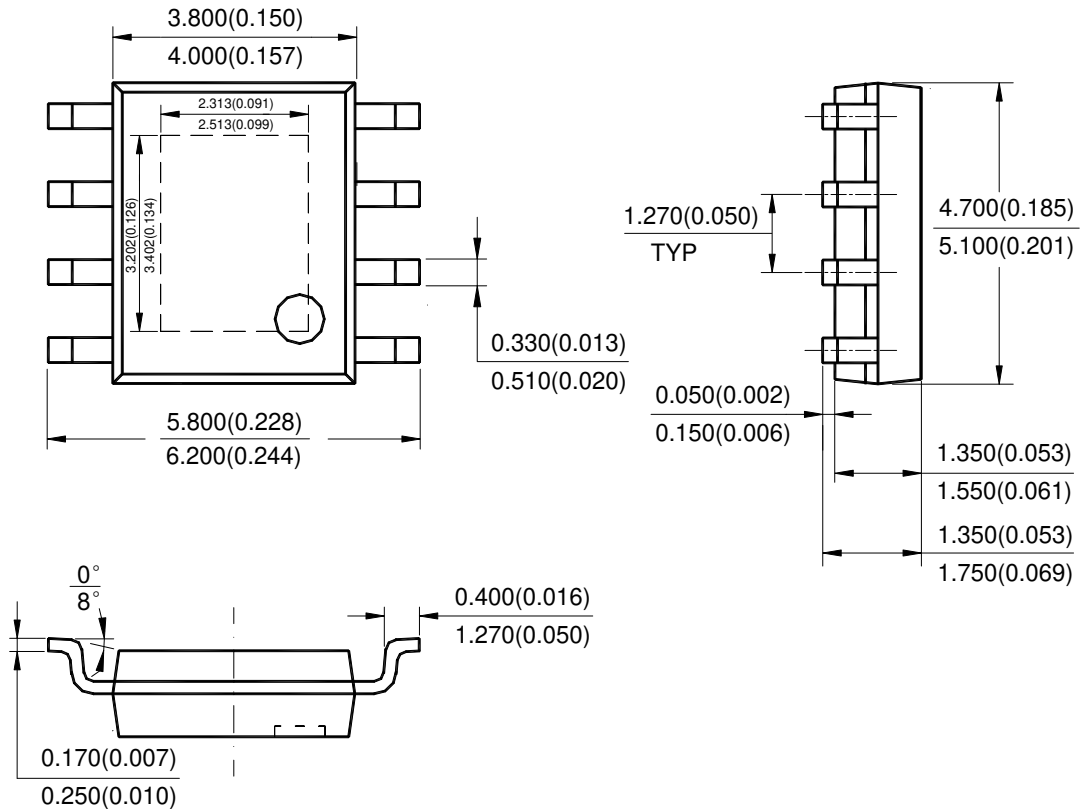

Note: Eject hole, oriented hole and mold mark is optional.

IMPORTANT NOTICE

DIODES INCORPORATED MAKES NO WARRANTY OF ANY KIND, EXPRESS OR IMPLIED, WITH REGARDS TO THIS DOCUMENT, INCLUDING, BUT NOT LIMITED TO, THE IMPLIED WARRANTIES OF MERCHANTABILITY AND FITNESS FOR A PARTICULAR PURPOSE (AND THEIR EQUIVALENTS UNDER THE LAWS OF ANY JURISDICTION).

Diodes Incorporated and its subsidiaries reserve the right to make modifications, enhancements, improvements, corrections or other changes without further notice to this document and any product described herein. Diodes Incorporated does not assume any liability arising out of the application or use of this document or any product described herein; neither does Diodes Incorporated convey any license under its patent or trademark rights, nor the rights of others. Any Customer or user of this document or products described herein in such applications shall assume all risks of such use and will agree to hold Diodes Incorporated and all the companies whose products are represented on Diodes Incorporated website, harmless against all damages.

Diodes Incorporated does not warrant or accept any liability whatsoever in respect of any products purchased through unauthorized sales channel. Should Customers purchase or use Diodes Incorporated products for any unintended or unauthorized application, Customers shall indemnify and hold Diodes Incorporated and its representatives harmless against all claims, damages, expenses, and attorney fees arising out of, directly or indirectly, any claim of personal injury or death associated with such unintended or unauthorized application.

Products described herein may be covered by one or more United States, international or foreign patents pending. Product names and markings noted herein may also be covered by one or more United States, international or foreign trademarks.

This document is written in English but may be translated into multiple languages for reference. Only the English version of this document is the final and determinative format released by Diodes Incorporated.

LIFE SUPPORT

Diodes Incorporated products are specifically not authorized for use as critical components in life support devices or systems without the express written approval of the Chief Executive Officer of Diodes Incorporated. As used herein:

A. Life support devices or systems are devices or systems which:

1. are intended to implant into the body, or
2. support or sustain life and whose failure to perform when properly used in accordance with instructions for use provided in the labeling can be reasonably expected to result in significant injury to the user.

B. A critical component is any component in a life support device or system whose failure to perform can be reasonably expected to cause the failure of the life support device or to affect its safety or effectiveness.

Customers represent that they have all necessary expertise in the safety and regulatory ramifications of their life support devices or systems, and acknowledge and agree that they are solely responsible for all legal, regulatory and safety-related requirements concerning their products and any use of Diodes Incorporated products in such safety-critical, life support devices or systems, notwithstanding any devices- or systems-related information or support that may be provided by Diodes Incorporated. Further, Customers must fully indemnify Diodes Incorporated and its representatives against any damages arising out of the use of Diodes Incorporated products in such safety-critical, life support devices or systems.

Copyright © 2018, Diodes Incorporated

www.diodes.com