

THIS COPY IS PROVIDED ON A RESTRICTED BASIS AND IS NOT TO BE USED IN ANY WAY DETRIMENTAL TO THE INTERESTS OF PANDUIT CORP.

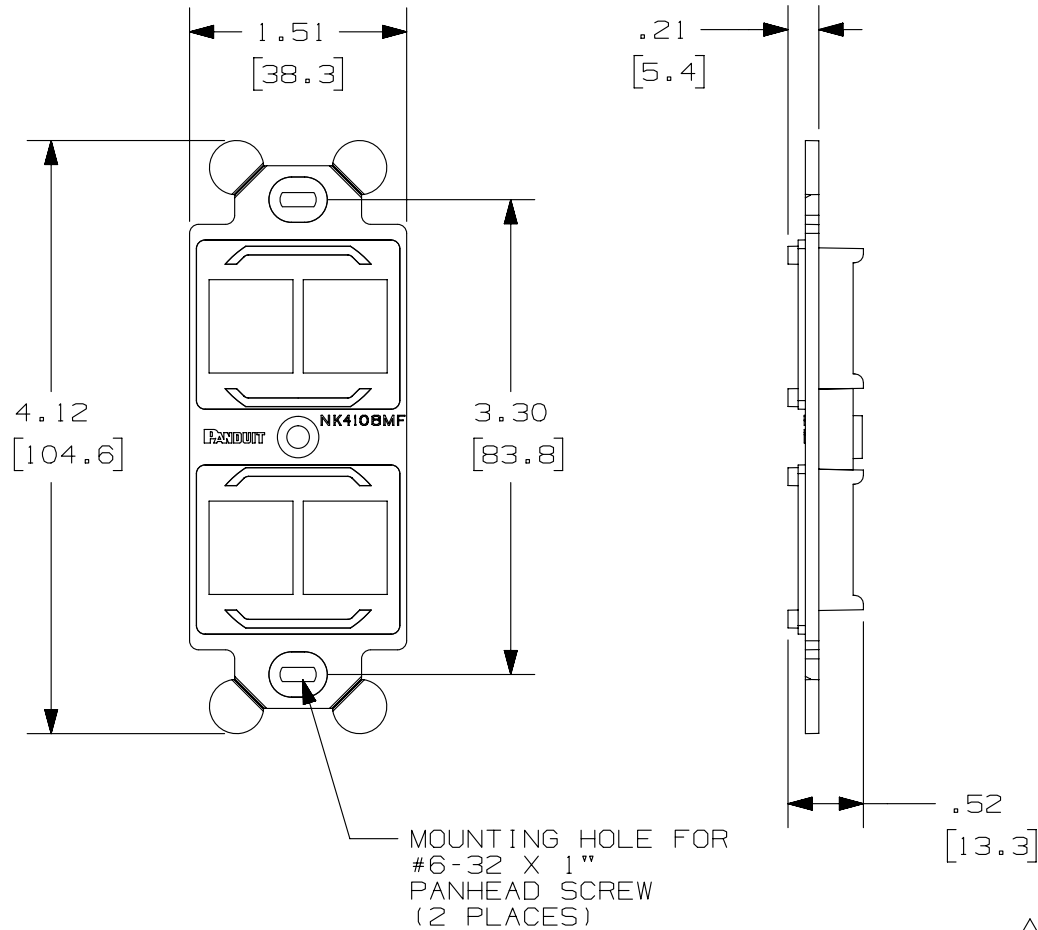

PANDUIT P/N	WEIGHT
NK4106MF**	.03 lb EACH (12.2 g EACH)

NOTES:

1. SEE CURRENT CATALOG FOR ADDITIONAL PART NUMBER SUFFIXES TO INDICATE COLOR AND OR PACKAGE QUANTITY.
2. FRAME ACCEPTS FOUR 4 NETKEY™ MODULES.
3. DIMENSIONS IN PARENTHESES ARE IN METRIC.
4. (2) #6-32 x 1" PANHEAD SCREWS ARE SUPPLIED.

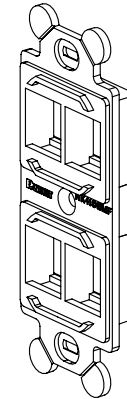

PART NUMBER		NK4106MF**	
TITLE			
NETKEY 4 POSITION "106" STYLE MODULE FRAME			
CUSTOMER DRAWING			
ITEM REVISION NAME		D38378BA/05	
DATASET FILE NAME		D38378BA_DC03/05A	
UNLESS OTHERWISE SPECIFIED, DIMENSIONAL TOLERANCES ARE: IN (mm)		MATERIAL:	
.x ± .xxx ± .010 [.3]		ABS	
.xx ± .03 [.8] ANGLES ±		DRAWING NUMBER:	
THIRD ANGLE PROJECTION		38378-03	
DRAWN BY	DATE	CHK	SCALE
JSP	11-30-01	PM	NONE
REV	DATE	BY	CHK
DESCRIPTION		ECN	SIZE
			A

REV	DATE	BY	CHK	APR	DESCRIPTION	ECN
2	5-09-14	MDJR	REFR	JCK	B. UPDATED TITLE BLOCK.	38378-03
1	10-18-02	JSP	PBD	PBD	A. REVISED TITLE.	38378-03
R	11-30-01	JBN	PM	PM	RELEASED TO PRODUCTION	38378-03

D10100DA/14

2

1

2

1