

DRG NO. 36-00029-04 SH1 REV F

**PROPRIETARY DATA!**  
This document and information contained here may not be reproduced, used or disclosed without prior written permission of WESTCOR, a division of VICO Corporation.

REVISIONS				
ECO	REV	DESCRIPTION	DATE	APPROVED
473	A	PRODUCTION RELEASE	12-5-95	RBD
687	B	CHANGED MATERIAL	7-25-97	RBD
730	C	CHG NOTE 1J & 2J, WAS: L= 1MHL	12-01-97	RBD
1023	D	CHG: NOTES 2I, & 3.3 PER ECO	06-13-00	RBD
---	01	ADD PERMACORE B7-9040-26	11/10/00	RBD
1417	02	ADD SOURCE SHANGHI SUPER ELECT	09/07/04	RBD
1462	E	ADDED ROHS SPEC NOTE	06/21/05	LGK
1543	F	TAPE # 1350F WAS # 1298	09/01/05	LGK

**NOTES UNLESS OTHERWISE SPECIFIED**

1. MATERIALS: UL RECOGNIZED 94V-2 FLAMMABILITY RATING CLASS B (130°C) REQUIRED.

- 1.1 CORE: TOROID,  $\mu = 5000$   
MAGNETICS ZJ-43806-TC OR  
PERMACOR: B7-9040-26  
SHANGHAI SUPER LIGHT ELECTRONICS COMPONENTS LTD.  
P/N: T36X19X6.35-C, MATERIAL RSK (CAN BE USED IF ROHS COMPLIANT)

1.2 WIRE: UL RECOGNIZED 130°C RATING MAGNET WIRE, APPROVED MFR: ESSEX  
OTHER MFR HAS TO BE ROHS COMPLIANT CERTIFIED BEFORE USE.

- 1.3 OUTER WRAP: 3M #11 OR #69 OR #1350F  
OR PERMACEL #213

**2. SPECIFICATIONS**

- 2.1 L = .95MH MIN/COIL (1KHZ, 4Vrms)
- 2.2 DCR = 10 OHMS MAX/COIL
- 2.3 POWER LOSS = 2.0 W MAX @ 10A/COIL
- 2.4 HI-POT TEST COIL TO COIL, 250VDC TO INSURE INTEGRITY OF WINDING  
INSULATION/COVERING HAS NOT BEEN BREACHED.

**3. CONSTRUCTION**

- 3.1 WIND COILS EVENLY SPACED (NOTE POLARITY).
- 3.2 REMOVE INSULATION AND TIN LEADS APPROX FLUSH WITH THE CORE  
AS SHOWN, I.E. COIL MUST REST FLAT ON PCB.
- 3.3 WRAP INDUCTOR WITH TAPE, (PER NOTE 1.3). MARK PART NUMBER AND REVISION  
IN (BLACK) APPROX. WHERE SHOWN, USING A PERMANENT MARKING METHOD.

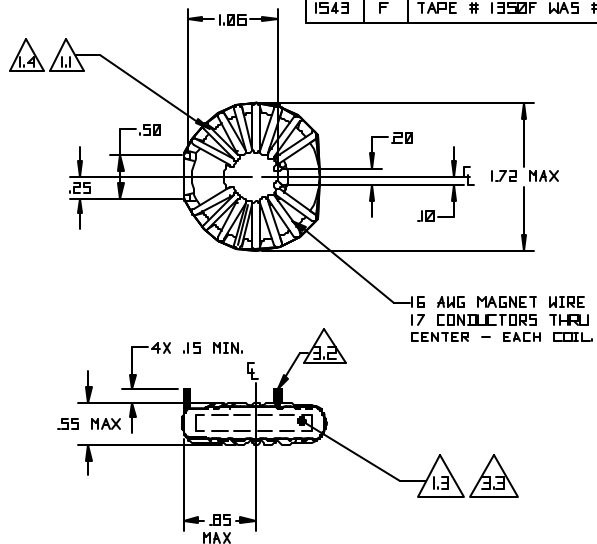

NOTE: CERTIFICATION OF MATERIAL COMPLIANCE REQUIRED.  
COMPLETED ASSEMBLY MUST BE (ROHS) COMPLIANT  
PER VICOR SPEC CST-0001.

UNLESS OTHERWISE SPECIFIED DIMENSIONS ARE IN INCHES TOLERANCES ARE		CONTRACT NO.		 WESTCOR a division of VICOR Corp.	
FRACTIONS: DECIMALS ANGLES		---			
± --- XX ± .05 XXX ± .005 ± °		APPROVALS		DATE	
MATERIAL		DRAWN		8/04/94	
SEE NOTES		CHECKED		LTKING 7/26/97	
FINISH		APPROVED		R.B. DRABING 11/1/94	
NEXT ASSY USED ON		DESIGNED		R.B. DRABING 8/4/94	
APPLICATION		DO NOT SCALE DRAWING		SIZE	8
				CAGE CODE	---
				DRG NO.	36-00029-04
				REV	F
				SCALE	NTS
				FILENAME	36-00029-04
				SHEET	1 OF 1

IND COMMON MODE 1.27MH 10A