

THIS DRAWING IS UNPUBLISHED. RELEASED FOR PUBLICATION  
 © COPYRIGHT - By - ALL RIGHTS RESERVED.

LOC	DIST	REVISIONS			
P	LTR	DESCRIPTION	DATE	DWN	APVD
AF	50	U	REVISED PER ECR-13-004343	30JUL13	KH KR

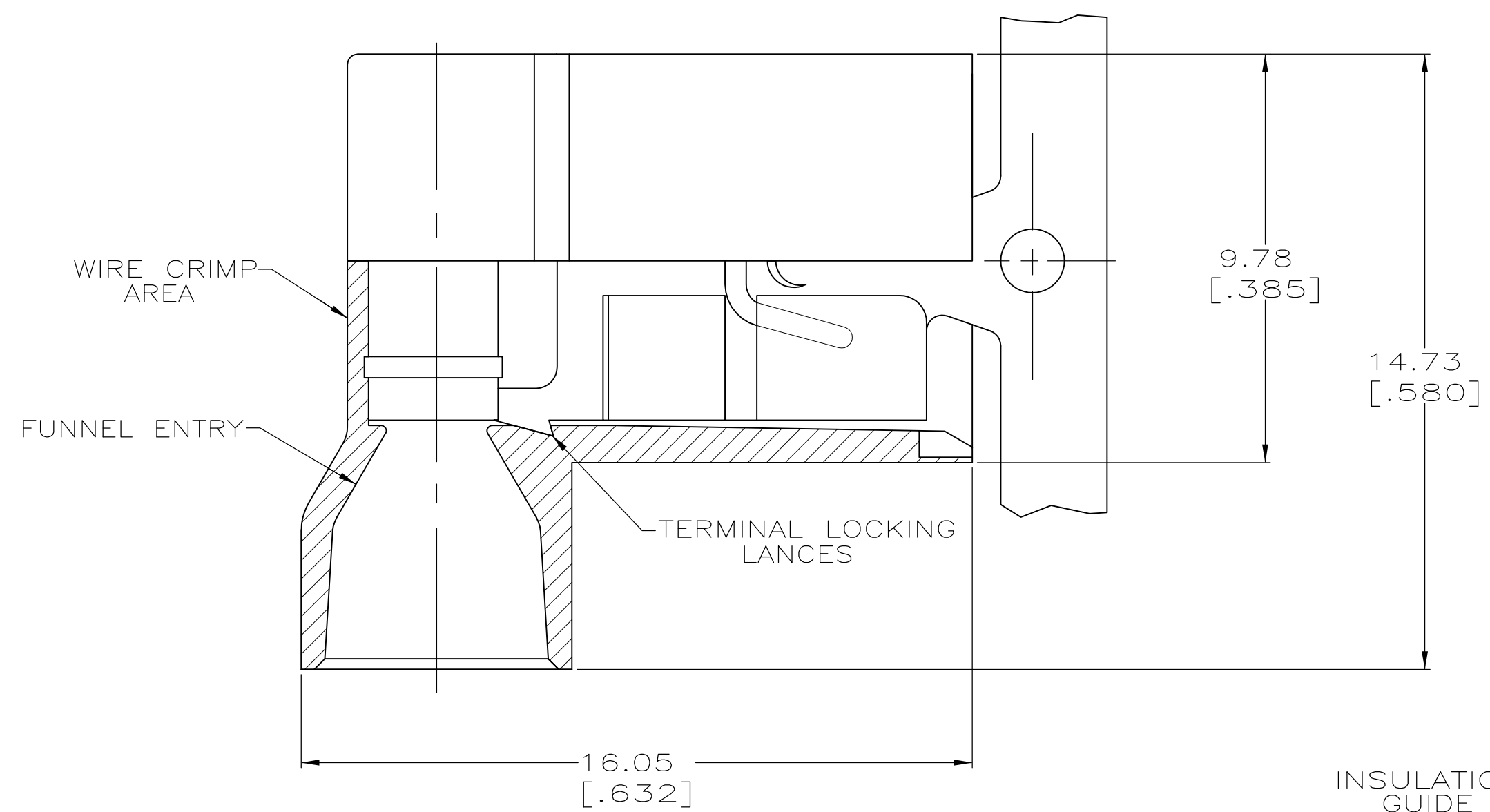

- 1 FITS 0.81±0.025 X 6.35 [.032±.001 X .250] TAB
- 2 WIRE SIZE: 1.3-2.0mm<sup>2</sup> [16-14 AWG], STRANDED ONLY. STRIP LENGTH 7.94 [.312]
- 3 INSULATION SIZE: 4.70 [.185] MAX DIA.
- 4 CONTINUOUS STRIP.

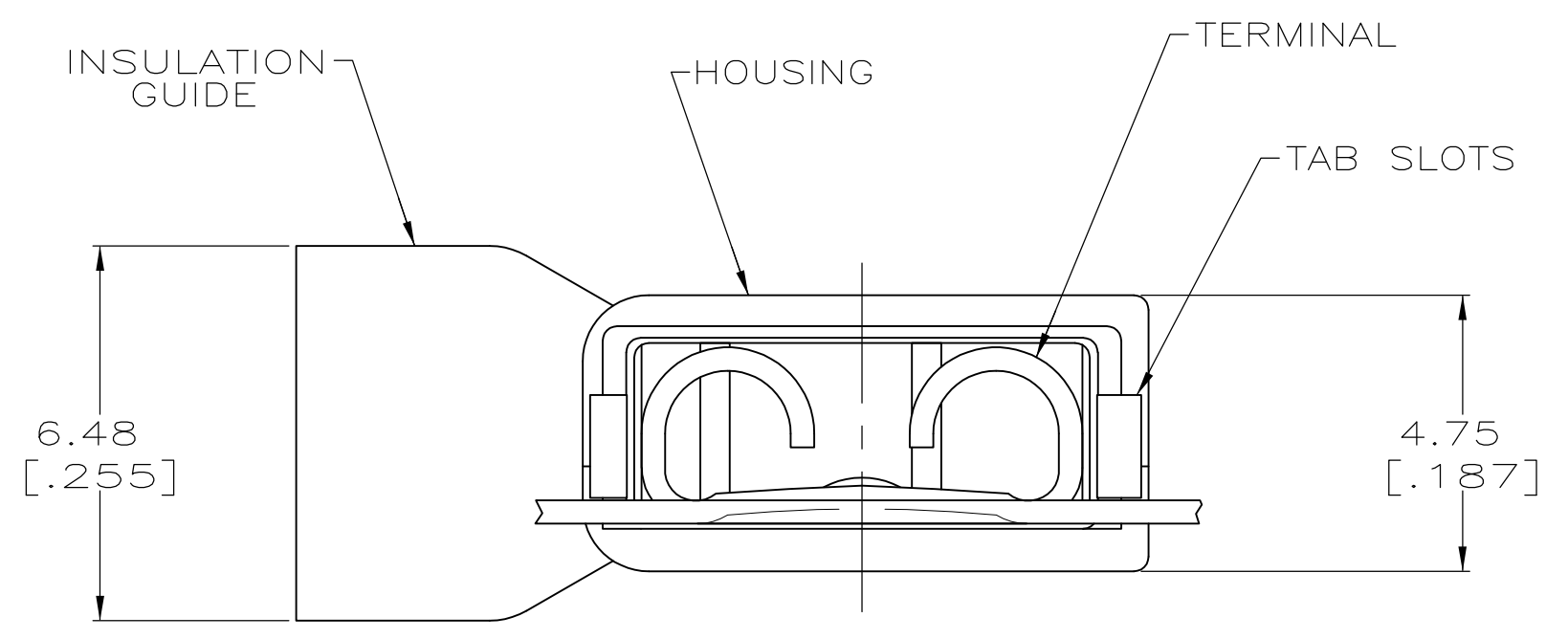
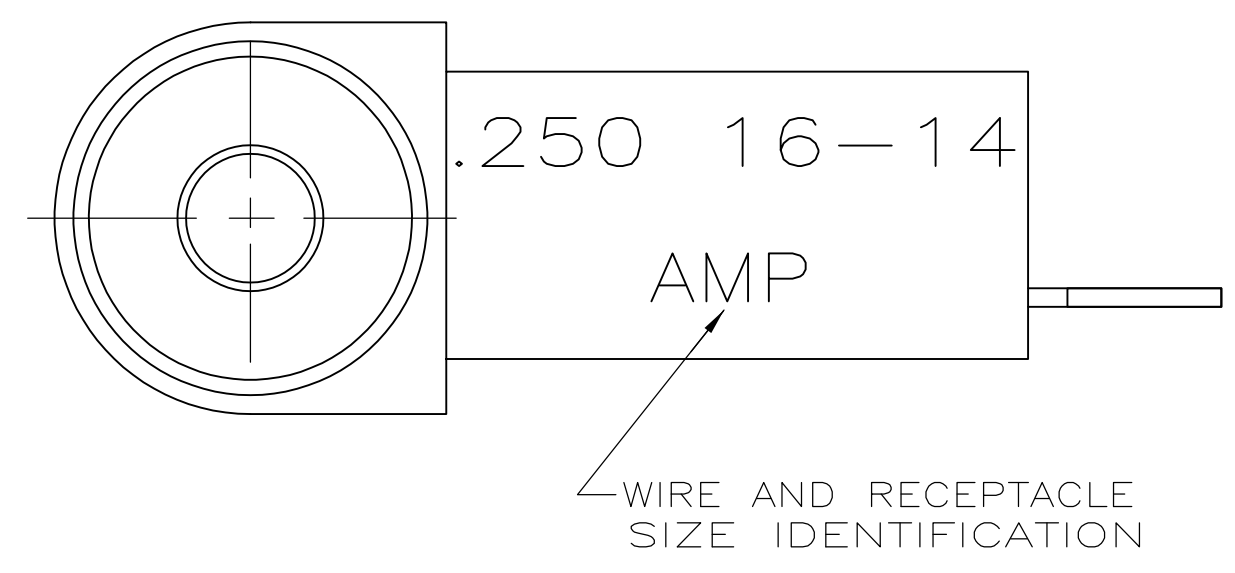

BULK	TYPE 6/6 NYLON	BLUE TRANSLUCENT	BRASS	TIN	5-520132-2
STANDARD		BLACK TRANSLUCENT			9-520132-2
		BLUE TRANSLUCENT			3-520132-2
PACKAGING	MATERIAL	COLOR	MATERIAL	FINISH	PART NO
THIS DRAWING IS A CONTROLLED DOCUMENT.		HOUSING		TERMINAL	
DWN P FORTNEY 11/10/89		APVD DJ BRATINA 11/10/89		NAME	
CHK JR RUTH 11/10/89		PRODUCT SPEC		RECEPTACLE ASSEMBLY, ULTRA-FAST FLAG, 6.35 [.250] SERIES	
APVD DJ BRATINA 11/10/89		APPLICATION SPEC		SIZE	
DIMENSIONS: mm [INCHES]		TOLERANCES UNLESS OTHERWISE SPECIFIED:		CAGE CODE	
0 PLC ± -		1 PLC ± -		DRAWING NO	
1 PLC ± -		2 PLC ± -		RESTRICTED TO	
2 PLC ± -		3 PLC ± 0.38 [.015]		A2 00779 C=520132	
3 PLC ± -		4 PLC ± -		SCALE	
4 PLC ± -		ANGLES ± -		8:1	
FINISH		WEIGHT		SHEET	
SEE TABLE		-		1 of 1	
		CUSTOMER DRAWING		REV	
				U	