

H
G
F
E
D
C
B
A

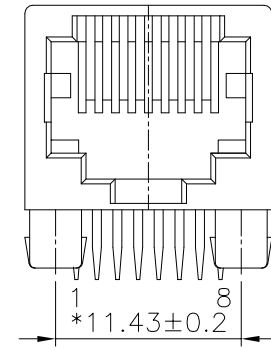
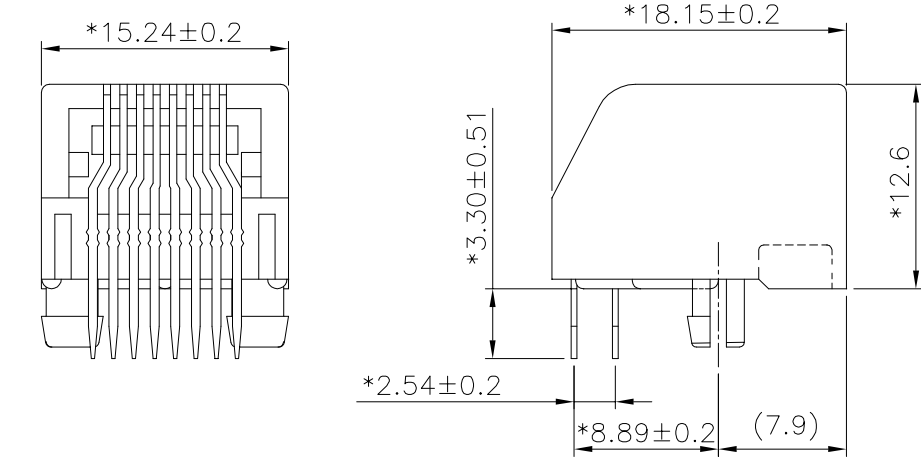

NOTES:

ELECTRICAL:

1. VOLTAGE RATING : 125 VAC RMS.
2. CURRENT RATING : 1.5 AMP.
3. CONTACT RESISTANCE : 35 MILLIOHMS MAX.
4. INSULATION RESISTANCE: 1000 MEGOHMS MIN @ 500 VDC.
5. DIELECTRIC STRENGTH : 1000 VAC RMS 60Hz, 1MIN.

MECHANICAL:

1. HOUSING MATERIAL : GLASS FILLED PBT UL94V-0. COLOR:BLACK
2. CONTACT MATERIAL : PHOSPHOR BRONZE t=0.35mm.
3. PLATING : CONTACT AREA-SELECTIVE GOLD PLATING.
: TAILS-TIN 150u" MIN OVER NICKEL.
4. OPERATING LIFE : 750 CYCLES MIN.
5. PCB RETENTION PRE-SOLDER : 1 LB MIN.
6. PCB RETENTION POST-SOLDER: 10 LBS MIN.

ENVIRONMENTAL:

1. STORAGE TEMPERATURE : -40°C TO +85°C.
 2. OPERATION TEMPERATURE : -40°C TO +85°C.
 3. WAVE SOLDERING TEMPERATURE: 230~250°C (5~10 SECONDS)
 4. RoHS COMPLIANT.
- MATES WITH MODULAR PLUG CONFORMING TO
FCC PART 68, SUBPART F.
CUL FILE NO. E163191

PART NUMBER	GOLD PLATING
E6288-000221-L	3u"
E6288-000222-L	6u"
E6288-000224-L	30u"

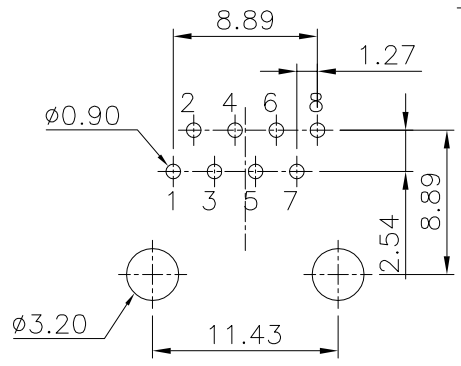
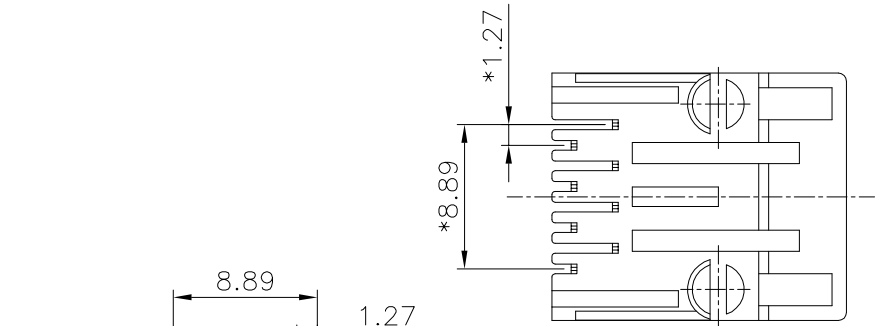

PC Board Layout T=1.6mm
Component Side Shown Tolerance±0.05mm

DETACHED LISTS	MM (INCH)	RoHS Compliant			
	TOLERANCES EXCEPT AS NOTED				
	MM		TITLE		
	.0 ± 0.2 .00 ± 0.15 .000 ± 0.075	± ± ±	AMP L/P SIDE ENTRY PCB JACK 8P		
ANGLES ± 0.5		DFTO Cathy	DRAWING NO. CE623053-LC	SIZE	REV
		DATE 2006/09/20	/PART NO. SEE TABLE	A3	0
		SCALE : FREE	DO NOT SCALE DRAWING	SHEET 1	OF 1

8 | | 7 | | 6 | | 5 | | 4 | | 3 | | 2 | | 1