

MLX91204 Triaxis® Resolver (Sine/Cosine)

Datasheet

Features and Benefits

- Absolute Rotary Position Sensor IC
- **Triaxis** Hall Technology
- Hi-Speed Operation
- Sine/Cosine Outputs
- Simple & Robust Magnetic Design
- Excellent Thermal Stability
- Very Low Hysteresis
- SOIC-8 Package (RoHS)

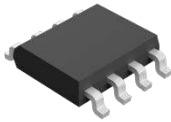

SOIC-8

Application Examples

- Absolute Rotary Position Sensor
- BLDC Motor Position Sensor (for Commutation)
- Contactless potentiometers
- Contactless encoder

Description

The Triaxis® rotary position sensor MLX91204 detects the absolute angular position of a small magnet that is positioned above the device surface.

The MLX91204 reports two analog, linear, orthogonal (quadrature) and ratiometric output voltages proportional to the applied magnetic flux density parallel to the chip surface (thanks to the Integrated Magneto Concentrator – IMC® – added on the top of the sensitive Hall elements).

The MLX91204 is ideally suited for hi-speed rotary position sensing in harsh automotive and industrial environments.

The angular position is computed off-chip from both sine and cosine signals.

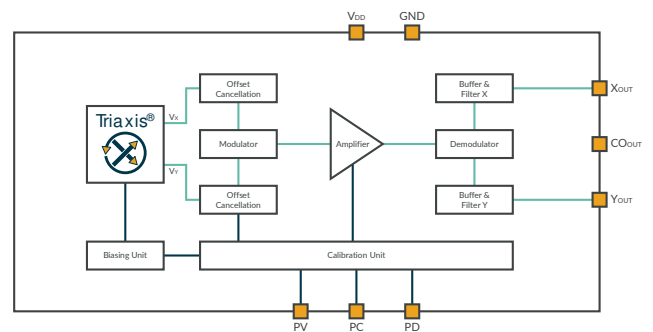

Ordering Information

Product	Temperature	Package	Option Code	Packing Form
MLX91204	K	DC	ABA-001	RE
MLX91204	K	DC	ABA-002	RE

Legend:

Temperature Code:	K: from -40°C to 125°C
Package Code:	“DC” for SOIC-8 package
Option Code:	ABA-xxx: die Version xxx-00 3 : 3 : Magnetic Field Range <ul style="list-style-type: none"> ▪ 1: High magnetic field (25 V/T typ) ▪ 2: Medium magnetic field (50 V/T typ)
Packing Form:	“RE” for Reel
Ordering Example:	“MLX91204KDC-ABA-001-RE” For a high magnetic field in SOIC-8 package, delivered in Reel.

Table 1 – Ordering information legend

Contents

Features and Benefits.....	1
Application Examples	1
Description.....	1
Ordering Information	2
1. Functional Diagram	4
2. Glossary of Terms.....	5
3. Absolute Maximum Ratings	5
4. Pinout and Function	5
5. MLX91204 General Electrical Specification.....	6
6. MLX91204 Sensor Specification.....	6
7. Recommended Application Diagrams.....	9
7.1. Single Ended Mode	9
7.2. Differential Mode.....	9
8. Standard information regarding manufacturability of Melexis products with different soldering processes.....	10
9. ESD Precautions.....	10
10. Package Information.....	11
10.1. Package Dimensions	11
10.2. Pinout and Marking	12
10.3. Hall Plate Positioning	12
11. Contact.....	13
12. Disclaimer.....	13

1. Functional Diagram

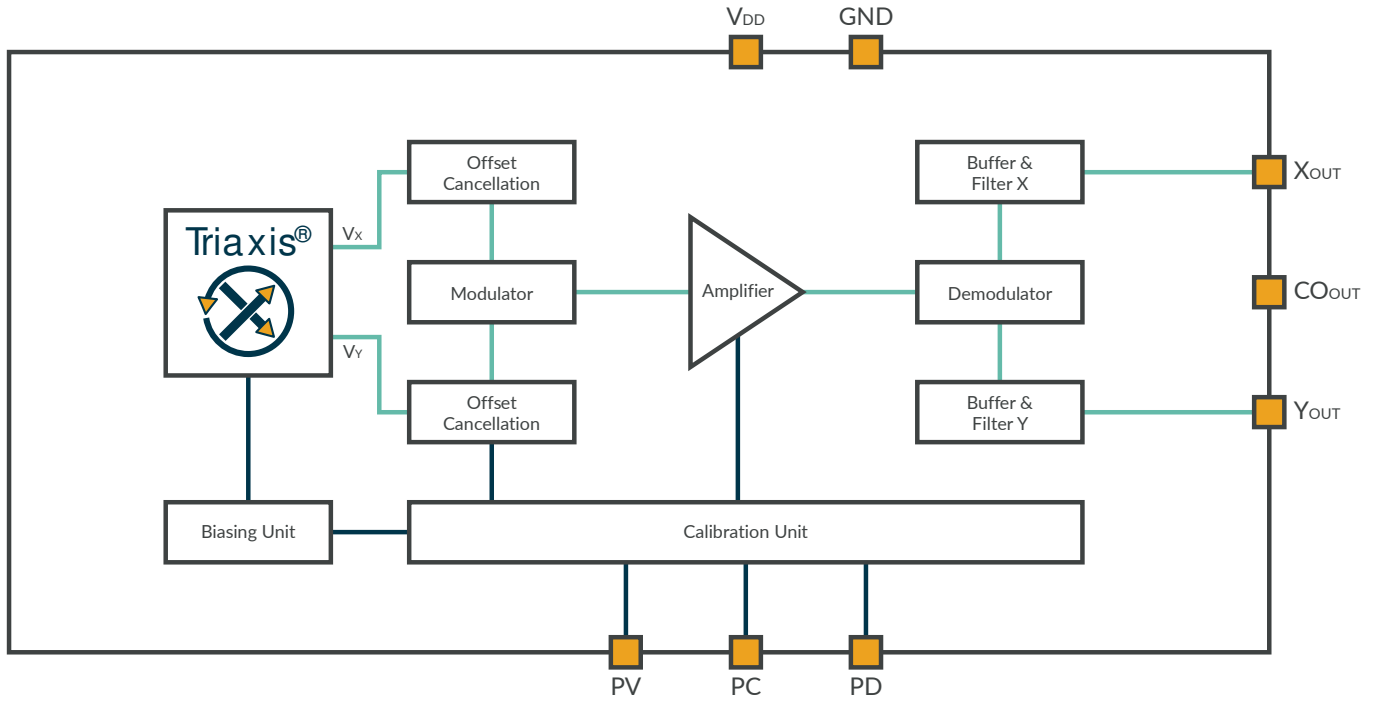

Figure 1 – MLX91204 Block Diagram

2. Glossary of Terms

- Gauss (G), Tesla (T): Magnetic flux density units where 1 mT = 10 G.
- Triaxis®: This technology refers to the Melexis Hall technology which allows the realization of Hall effect sensors able to sense the flux density along the 3 axis (i.e. X, Y & Z). In particular, it enables the realization of position sensors able to sense the magnetic flux density parallel to the IC surface and consequently the magnetic vector over 360 degrees.
- IMC: Integrated Magneto Concentrator. It concentrates the magnetic flux lines and bends them at the extremity under the planar Hall plates. Furthermore, it provides some magnetic gain factor.

3. Absolute Maximum Ratings

Parameter.	Units
Supply Voltage, VDD (overvoltage)	+ 6 V
Reverse Voltage Protection	- 0.5 V
Operating Temperature Range T _A	-40 to +125 Deg.C.
Storage Temperature Range, T _S	-40 to +150 Deg.C.

Exceeding the absolute maximum ratings may cause permanent damage. Exposure to absolute-maximum-rated conditions for extended periods may affect device reliability.

4. Pinout and Function

Pin #	Pin Name	Function
1	CO_OUT	Output Common (V _{DD} /2)
2	PC	Factory programming pin. Connect to V _{DD}
3	V _{DD}	Supply Voltage (+)
4	Y_OUT	Analog Output Y
5	X_OUT	Analog Output X
6	PD	Factory programming pin. Connect to GND
7	PV	Factory programming pin. Connect to V _{DD}
8	GND	Ground

5. General Electrical Specification

DC Operating Parameters $T_A = -40$ Deg.C. to $+125$ Deg.C., $V_{DD} = 5.0$ V (unless otherwise specified)

Parameter	Symbol	Test Conditions	Min	Typ	Max	Units
Nominal Supply Voltage	V_{DD}		4.5	5	5.5	V
Supply Current	I_{DD}	$I_{OUT} = 0$ mA		16.5	19	mA
Common Output	CO_{OUT}	Referring to $V_{DD}/2$, unloaded	- 2	0	2	% V_{DD}
Output Current CO_{OUT} and X_{OUT} and Y_{OUT}	I_{OUT}	Drop is typically 80mV/mA	- 1		1	mA
Output Load Resistance	R_L		5			k Ω
Output Load Capacitance	C_L				1000	pF
Start-up cycle	$t_{STARTUP}$			150	200	μ s

6. Sensor Specification

DC Operating Parameters $T_A = -40$ Deg.C. to 125 Deg.C., $V_{DD} = 5.0$ V, differential output (unless otherwise specified)

Parameter	Symbol	Test Conditions	Min	Typ	Max	Units
Offset Voltage	V_{OQ}	$T_A = 25$ Deg.C. – $B = 0$ mT X_{OUT} & Y_{OUT}	-10	0	10	mV
Offset Temperature Drift	$\Delta V_{OQ}/\Delta T$	$B = 0$ mT – X_{OUT} & Y_{OUT} ⁽¹⁾	-0.10	0	+0.10	mV/Deg.C.
Sensitivity	S	$T = 25$ Deg.C. Option Code : ABA-001	16	25	34	V/T
		$T = 25$ Deg.C. Option Code : ABA-002	32	50	68	V/T
Sensitivity Temperature Drift	$\Delta S/[S\Delta T]$	⁽¹⁾	-0.08	-0.05	-0.01	%/Deg.C.
Sensitivity Mismatch	S_{XY}	$S_{XY} = S_X/S_Y$	-3	0	3	%
Sensitivity Mismatch Temperature Drift	$\Delta(S_{XY})/\Delta T$	⁽¹⁾	-0.012	0	0.012	%/Deg.C.
Phase Mismatch	$\angle S_X - \angle S_Y$		-1	0	1	Degree

Parameter	Symbol	Test Conditions	Min	Typ	Max	Units
Hysteresis	H _{YST}	(1)	-20	±8	20	μT
Full Scale Magnetic Field Range (± 2 V Output Swing)	B _{FS}	Option Code: ABA-001			58.8	mT
		Option Code: ABA-002			29.4	mT
Max. Output Voltage Swing	V _{OUTMAX}	B > B _{FS} – X _{OUT} & Y _{OUT} I _{OUT} = 0 mA	0.25		4.75	V
Angular Speed	ω	2 poles magnet			100k	RPM
Bandwidth (-3dB)	BW	R _L > 1 MΩ – C _L < 10 pF		15		kHz
Spectral Noise Density	ΔB _{NOISE}				750	nT/Hz ^½

(1) Characterized

From the previous table and the ageing data, the intrinsic angular linearity error (in Degree) can be derived from the individual contributions as it follows:

Test Conditions	Parameters	Output Swing		Unit
		± 1 V	± 2 V	
Room Temperature (T _A = 25 Deg.C.)	Offset	± 0.8	± 0.4	Degree
	Sensitivity Mismatch	± 0.84	± 0.84	Degree
	Phase Mismatch	± 1	± 1	Degree
	Total	± 2.64	± 2.24	Degree
Temperature Range (T _A = -40 ... 125 Deg.C.)	Offset	± 0.8	± 0.4	Degree
	Sensitivity Mismatch	± 0.34	± 0.34	Degree
	Phase Mismatch	± 0.12	± 0.12	Degree
	Total	± 1.26	± 0.86	Degree
Lifetime/Ageing (HTOL 1000 hours – 5.0 V – 150 Deg.C.)	Offset	± 0.8	± 0.4	Degree
	Sensitivity Mismatch	± 0.1	± 0.1	Degree
	Phase Mismatch	± 0.1	± 0.1	Degree
	Total	± 1.00	± 0.60	Degree
Overall Linearity Error	Excl. Ageing	± 3.90	± 3.10	Degree
	Incl. Ageing	± 4.90	± 3.70	Degree

The intrinsic linearity error refers only to the linearity error associated to the MLX91204. The linearity error associated to the magnetic and mechanical (off-axis, eccentricity) design is not included and should be considered as an additional contribution.

For more information, please refer to the application note:

<https://www.melexis.com/en/documents/documentation/application-notes/application-note-mlx90316-magnet-selection>

The total error can be reduced either statically (room temperature compensation) or dynamically (continuous compensation) through the off-chip signal processing performing the angular computation i.e. $\arctan(Y_{OUT}/X_{OUT})$. The compensation is applied prior to computing the arctangent function: offset, gain and phase correction can be applied.

7. Recommended Application Diagrams

7.1. Single Ended Mode

The output voltages $X = (X_{OUT} - GND)$ and $Y = (Y_{OUT} - GND)$ are within 0.5V to 4.5V with an offset of 2.5V ($V_{DD}/2$)

For reliable operation within the specifications the sensor must be connected as follows:

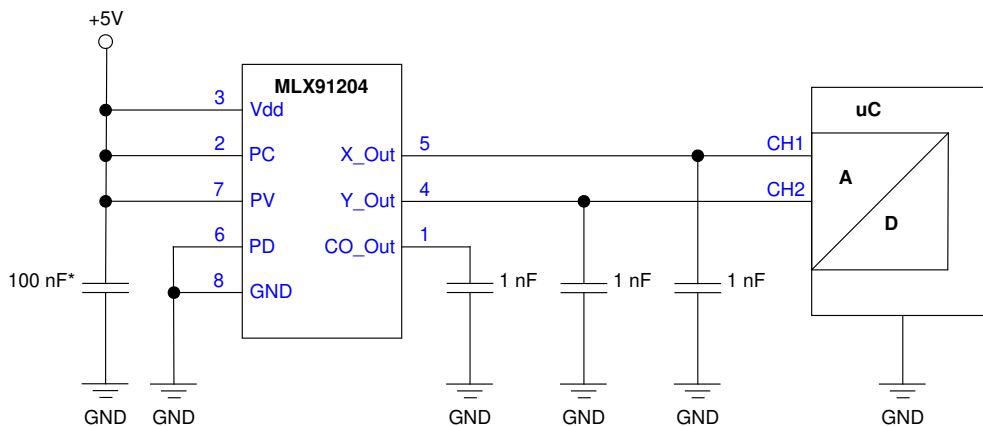

* if the supply voltage is disturbed by EMI it can be useful to place a second capacitor (100 pF ceramic) parallel to the 100nF capacitor.

7.2. Differential Mode

The output voltages $X = (X_{OUT} - CO_{OUT})$ and $Y = (Y_{OUT} - CO_{OUT})$ are within ± 2 V around “virtual ground” (i.e. $CO_{OUT} = 2.5V = V_{DD}/2$)

For reliable operation within the specifications the sensor must be connected as follows:

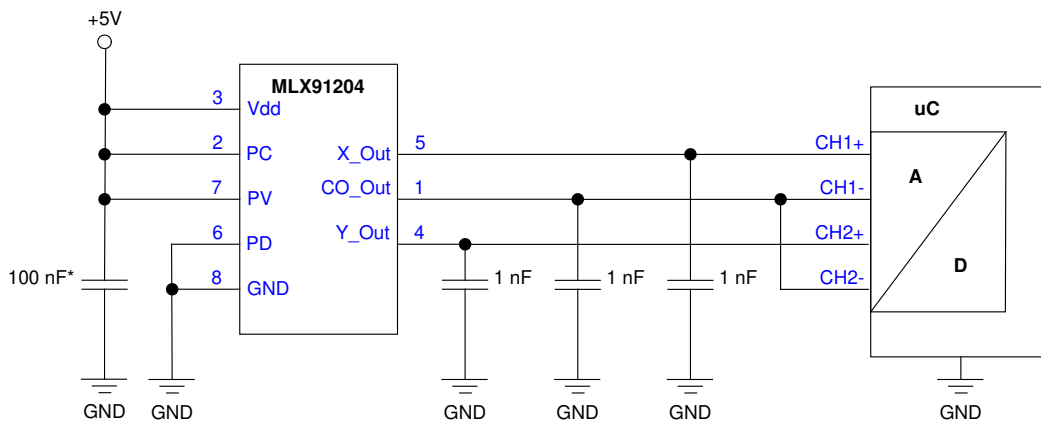

* if the supply voltage is disturbed by EMI it can be useful to place a second capacitor (100pF ceramic) parallel to the 100 nF capacitor.

8. Standard information regarding manufacturability of Melexis products with different soldering processes

Our products are classified and qualified regarding soldering technology, solderability and moisture sensitivity level according to standards in place in Semiconductor industry.

For further details about test method references and for compliance verification of selected soldering method for product integration, Melexis recommends reviewing on our web site the General Guidelines soldering recommendation (<http://www.melexis.com/en/quality-environment/soldering>)

For all soldering technologies deviating from the one mentioned in above document (regarding peak temperature, temperature gradient, temperature profile etc.), additional classification and qualification tests shall be agreed upon with Melexis.

For package technology embedding trim and form post-delivery capability, Melexis recommends consulting the dedicated trim & forming recommendation application note: lead trimming and forming recommendations (<http://www.melexis.com/en/documents/documentation/application-notes/lead-trimming-and-forming-recommendations>).

Melexis is contributing to global environmental conservation by promoting lead free solutions. For more information on qualifications of RoHS compliant products (RoHS = European directive on the Restriction Of the use of certain Hazardous Substances) please visit the quality page on our website: <http://www.melexis.com/en/quality-environment>.

9. ESD Precautions

Electronic semiconductor products are sensitive to Electro Static Discharge (ESD).

Always observe Electro Static Discharge control procedures whenever handling semiconductor products.

10. Package Information

10.1. Package Dimensions

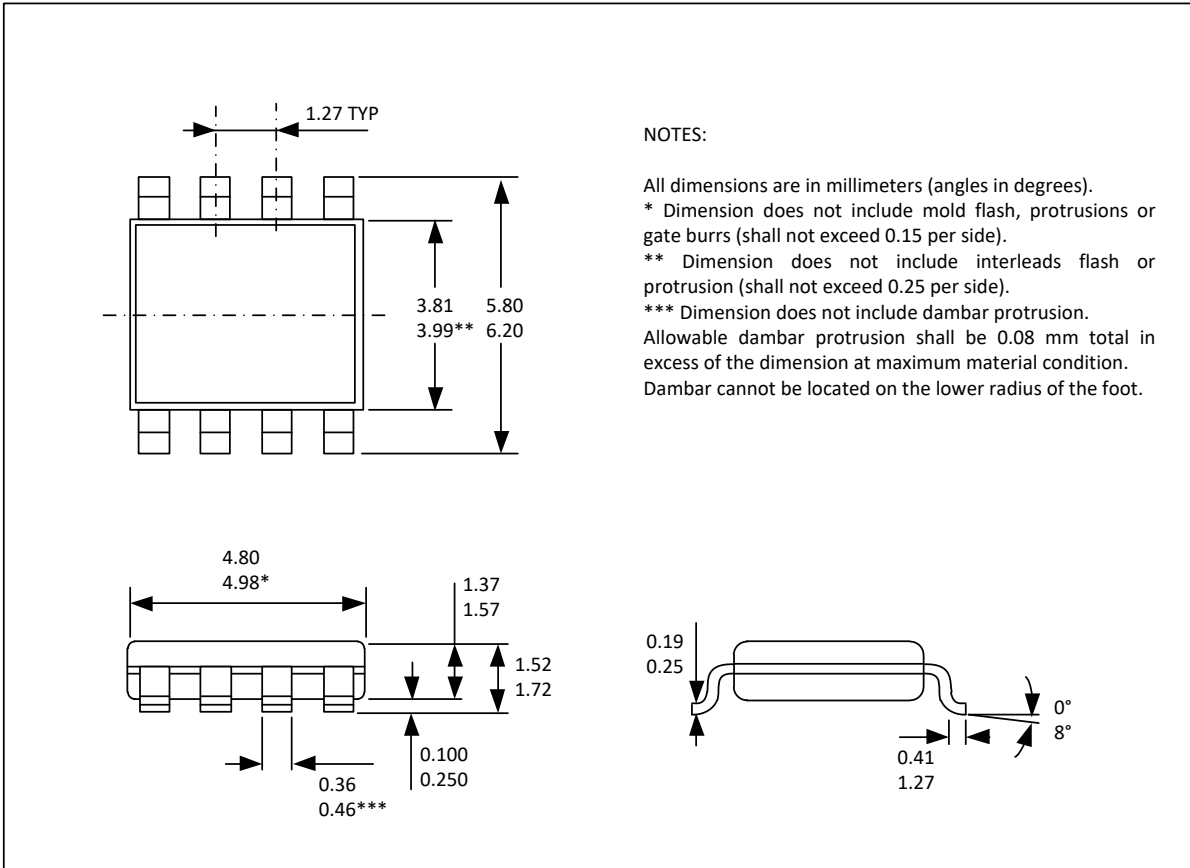

NOTES:

All dimensions are in millimeters (angles in degrees).
 * Dimension does not include mold flash, protrusions or gate burrs (shall not exceed 0.15 per side).
 ** Dimension does not include interleads flash or protrusion (shall not exceed 0.25 per side).
 *** Dimension does not include dambar protrusion. Allowable dambar protrusion shall be 0.08 mm total in excess of the dimension at maximum material condition. Dambar cannot be located on the lower radius of the foot.

10.2. Pinout and Marking

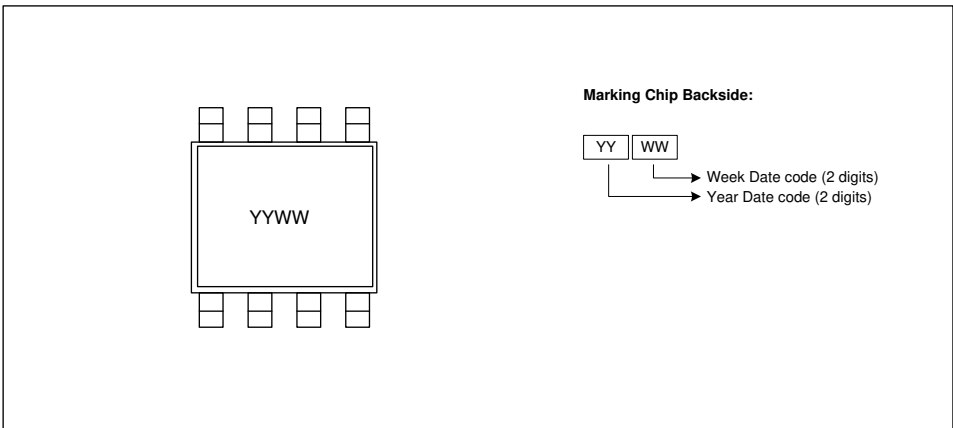
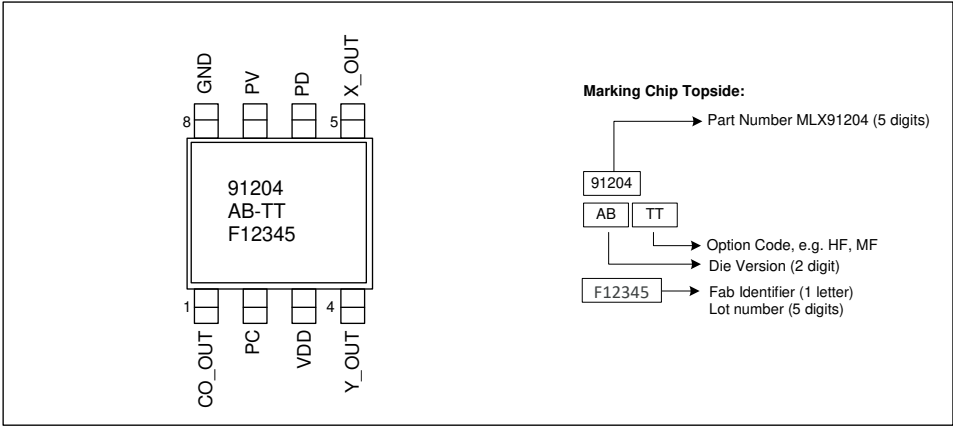

10.3. Hall Plate Positioning

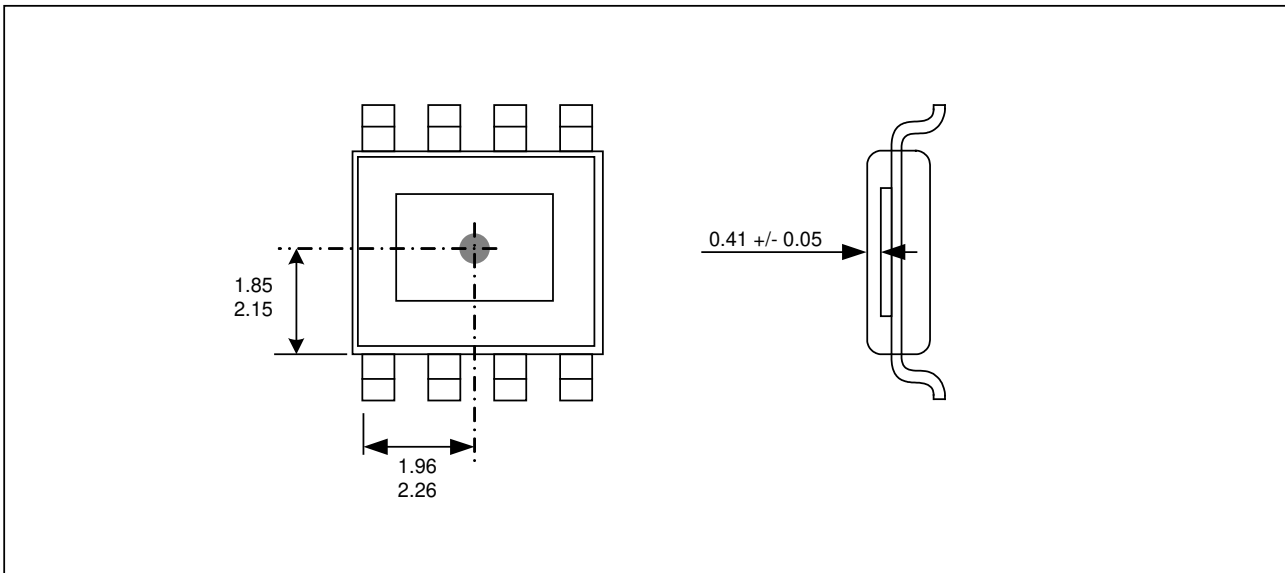

11. Contact

For the latest version of this document, go to our website at www.melexis.com.

For additional information, please contact our Direct Sales team and get help for your specific needs:

Europe, Africa	Telephone: +32 13 67 04 95
	Email : sales_europe@melexis.com
Americas	Telephone: +1 603 223 2362
	Email : sales_usa@melexis.com
Asia	Email : sales_asia@melexis.com

12. Disclaimer

The information furnished by Melexis herein ("Information") is believed to be correct and accurate. Melexis disclaims (i) any and all liability in connection with or arising out of the furnishing, performance or use of the technical data or use of the product(s) as described herein ("Product") (ii) any and all liability, including without limitation, special, consequential or incidental damages, and (iii) any and all warranties, express, statutory, implied, or by description, including warranties of fitness for particular purpose, non-infringement and merchantability. No obligation or liability shall arise or flow out of Melexis' rendering of technical or other services.

The Information is provided "as is" and Melexis reserves the right to change the Information at any time and without notice. Therefore, before placing orders and/or prior to designing the Product into a system, users or any third party should obtain the latest version of the relevant information to verify that the information being relied upon is current.

Users or any third party must further determine the suitability of the Product for its application, including the level of reliability required and determine whether it is fit for a particular purpose.

The Information is proprietary and/or confidential information of Melexis and the use thereof or anything described by the Information does not grant, explicitly or implicitly, to any party any patent rights, licenses, or any other intellectual property rights.

This document as well as the Product(s) may be subject to export control regulations. Please be aware that export might require a prior authorization from competent authorities.

The Product(s) are intended for use in normal commercial applications. Unless otherwise agreed upon in writing, the Product(s) are not designed, authorized or warranted to be suitable in applications requiring extended temperature range and/or unusual environmental requirements. High reliability applications, such as medical life-support or life-sustaining equipment are specifically not recommended by Melexis.

The Product(s) may not be used for the following applications subject to export control regulations: the development, production, processing, operation, maintenance, storage, recognition or proliferation of 1) chemical, biological or nuclear weapons, or for the development, production, maintenance or storage of missiles for such weapons; 2) civil firearms, including spare parts or ammunition for such arms; 3) defense related products, or other material for military use or for law enforcement; 4) any applications that, alone or in combination with other goods, substances or organisms could cause serious harm to persons or goods and that can be used as a means of violence in an armed conflict or any similar violent situation.

The Products sold by Melexis are subject to the terms and conditions as specified in the Terms of Sale, which can be found at <https://www.melexis.com/en/legal/terms-and-conditions>.

This document supersedes and replaces all prior information regarding the Product(s) and/or previous versions of this document.

Melexis NV © - No part of this document may be reproduced without the prior written consent of Melexis. (2019)

ISO/TS 16949 and ISO14001 Certified