

Using the TPS2458EVM

User's Guide



Literature Number: SLUU348A
February 2009–Revised August 2009

TPS2458 ATCA™ AdvancedMC™ Controller

1 Introduction

The AdvancedMC™ Controller Evaluation Module (EVM) is a PCB platform for users to learn about the features and operation of the TPS2458 integrated circuit (IC) from Texas Instruments (TI). The TPS2458 ATCA™ AdvancedMC™ Controller IC manages a 12-V and a 3.3-V power rail and features inrush and fault current limiting, FET OR'ing, input UVLO protection and logic-level enable inputs. Current control on the 12-V rail has a high degree of programmability, including independent current limit and fast trip thresholds. Overcurrent fault timing is managed with user-programmable shut-down delays, and each of the two power channels has dedicated fault and power good reporting outputs. In addition, current sense and pass and block FET's for the 3.3-V channel is fully integrated into the device.

Power management applications based on the TPS2458 are easily configured to meet the requirements for 12-V and 3.3-V control of Advanced Mezzanine Card (AdvancedMC™) modules. Each device incorporated onto a Carrier Card provides full control for an AdvancedMC™ slot according to the requirements of the Advanced Telecommunications Computing Architecture (ATCA™) specification, PICMG 3.0.

2 Description

2.1 Module Overview

The TPS2458EVM is a single-board evaluation platform consisting of two main sections. When oriented with the board nomenclature and switch labels in a normal, upright reading position towards the user, the top portion contains the TPS2458 IC and typically required components. The bottom section contains more ancillary circuitry intended to facilitate exercising the device through various application scenarios. Power connectors are organized with inputs along the left edge of the board, outputs along the right.

The main (upper) section of the board is comprised of the two power channels, including the featured device, support passives, input and output banana jacks, control FET's (for 12-V rail), and power planes. The board contains various capacitors for simulation of input bulk capacitance as may be present on driven AdvancedMC™ modules; alternatively, the user's test loads can be connected at the output banana jacks. Various timing capacitor options, for each power rail, are available and user-selectable via DIP switch S4. Numerous jumpers are provided throughout the circuit for maximum configuration flexibility. Test points are available for voltage and waveform monitoring.

The bottom section contains expansion port connectors and the status LED's. Slide switches for actuation of the chip enable inputs are organized in a row along the bottom edge of the PCB.

2.2 Features

The TPS2458EVM includes the following features:

- One TPS2458 ATCA™ AdvancedMC™ Controller IC
- Programming and sense resistors (12-V)
- Low $R_{DS(ON)}$ pass and block FET's (12-V)
- Input and output power jacks for external supply and optional load connection
- up to 880 μF ($4 \times 220 \mu\text{F}$) jumpered load capacitors (12-V channel) for simulated Payload Power output bulk capacitance
- 150 μF jumpered load capacitor for the Management Power channel
- Multiple, switch-selectable fault timer settings, each channel
- Slide switch actuation of enable inputs
- Expansion port headers

The use of these features is described in greater detail later in this document.

3 Electrical Specifications

3.1 Absolute Maximum Ratings

The absolute maximum ratings for the TPS2458EVM are given in [Table 1](#).

Table 1. Absolute Maximum Ratings⁽¹⁾⁽²⁾

	RATING	UNIT
Input voltage range, 12-V supply	-0.3 to 13.8	V
Input voltage range, 3.3-V supply	-0.3 to 4	
Applied voltage, pins of J21, J22 $\overline{\text{EN}}12\text{x}$, $\overline{\text{OREN}}\text{x}$	-0.3 to $(V_{IN}(12V\text{INx}) + 0.5)$	
Applied voltage, pins of J21, J22 SUMx, $\overline{\text{EN}}3\text{x}$	-0.3 to $(V_{IN}(3V3\text{INx}) + 0.5)$	
Output current, 12-V outputs	10	A
Output current, 3.3-V outputs	Internally limited by device	
Output current, SUMx	-5	mA
Storage temperature range	-55 to 150	°C

(1) All voltages are with respect to the EVM GND node.

(2) Currents are positive into and negative out of the specified terminal.

3.2 Recommended Operating Conditions

The recommended operating conditions for the TPS2458EVM are given in [Table 2](#).

Table 2. Recommended Operating Conditions, TPS2458EVM⁽¹⁾⁽²⁾

	MIN	TYP	MAX	UNITS
Input supply voltage, 12 V	8.8	12	13.2	V
Input supply voltage, 12 V (for specified V_{OUT})	11.3	12	13.2	
Input supply voltage, 3.3 V	2.85	3.3	3.5	
Input supply voltage, 3.3 V (for specified V_{OUT})	3.235	3.3	3.465	
Load current, payload power out (either channel)			-7.4	A
Load current, management power out (either channel)			-165	mA

(1) All voltages are with respect to the EVM GND node.

(2) Currents are positive into and negative out of the specified terminal.

4 Schematic Diagrams

The schematic diagrams for the TPS2458EVM is shown in [Figure 1](#).

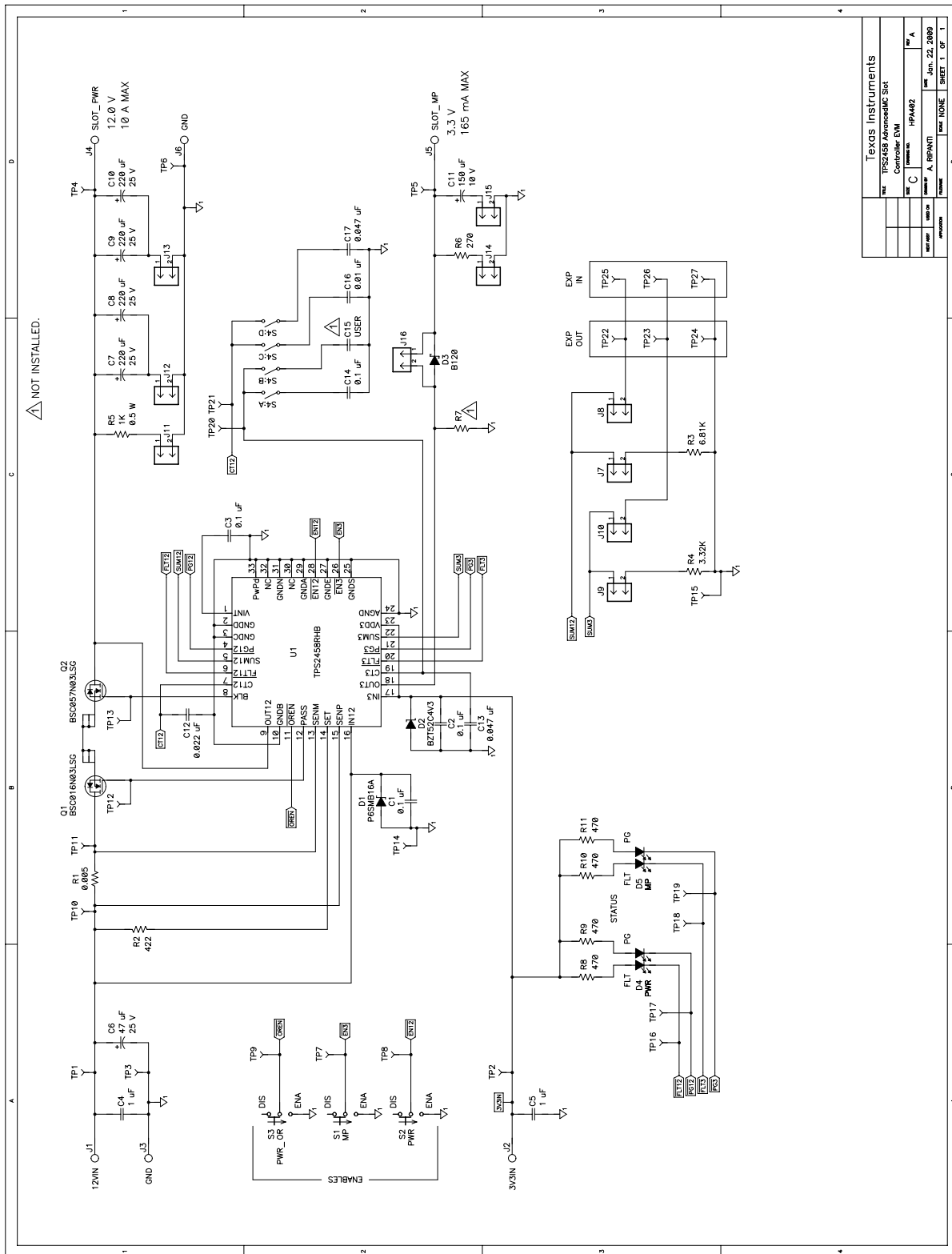

Figure 1. TPS2458 Evaluation Module Schematic Diagram

5 Test Set-Up

5.1 Equipment Requirement

The following test and interface equipment (not supplied) is required to verify EVM module operation, and begin using the EVM.

- Power supply, 3.3 VDC, 500 mA minimum
- Power supply, 15 VDC, 10 A minimum
- Digital multimeters
- Oscilloscope, 4 channel, with current probe

Connect the TPS2458EVM and test equipment as shown in [Figure 2](#) for functional check-out of the board and a good starting point for user evaluation of device operation. Screen print labeling on the board employs a naming convention in keeping with the nomenclature of the target ATCA™ and MicroTCA™ applications. Input 3.3-V supply is connected to the 3V3IN jack, and the 12-V supply is connected to the 12VIN jack. A cross-reference of power rail labeling to standards naming is shown in [Table 3](#).

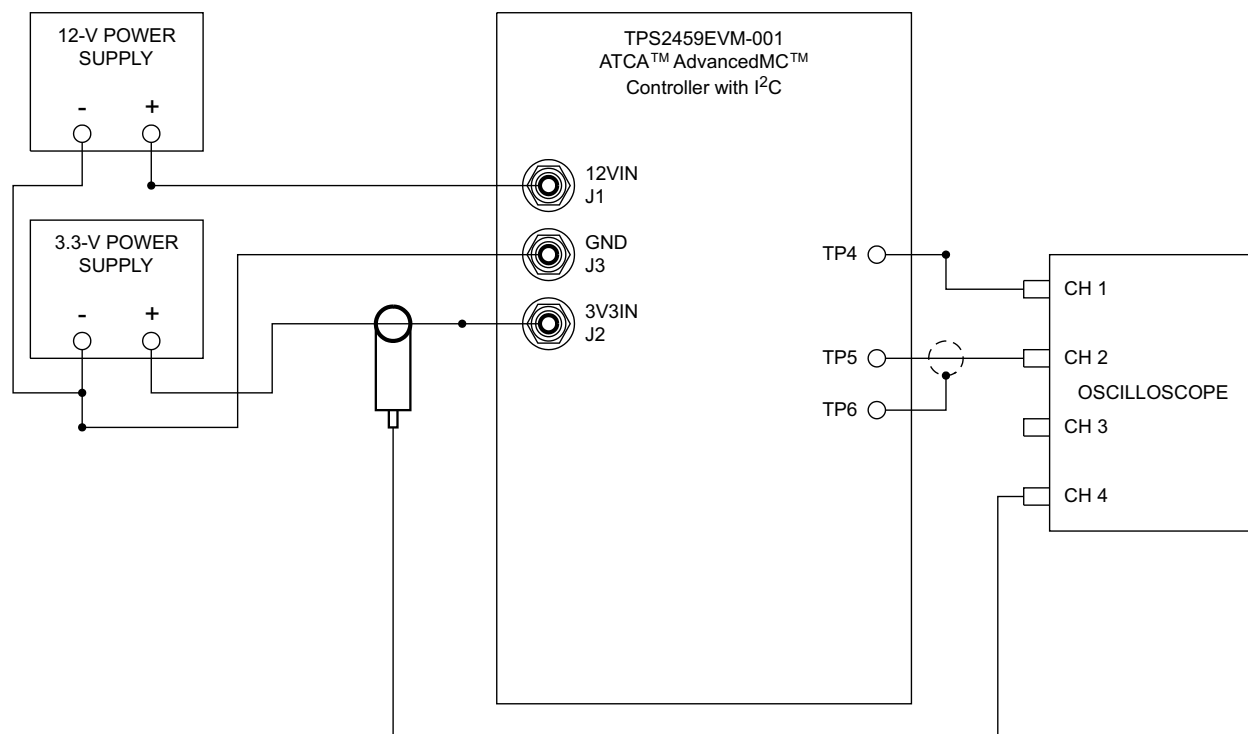

Figure 2. Connection Diagram

Note: Run separate leads from the GND jacks back to a common return point made near the power supply output terminals.

Table 3. TPS2458EVM Output Net and Jack Naming

REF DES	CONNECTOR LABEL	DESCRIPTION
J4	SLOT PWR	AdvancedMC™ Slot Payload Power
J5	SLOT MP	AdvancedMC™ Slot Management Power
J6	GND	Common load return node

5.2 Jumper Installation

The TPS2458EVM makes use of various jumpers for quick change of functional configurations. Verify the module was supplied with shunt jumpers installed across the headers listed in [Table 4](#). For 3-pin headers, note the pin pairs to be connected. Reconfigure jumper connections if necessary.

Table 4. Initial Jumper Settings

SIGNAL AND CONTROL JUMPERS
J7, J9
J11–J16

On the EVM board, place the ENABLE slide switches, located along the bottom edge of the PCB, in the initial positions shown in [Table 5](#).

Table 5. ENABLE Switch Initial Positions

SECTION	SWITCH NAME	INITIAL POSITION
SLOT	MP	DIS
	PWR	DIS
	PWR_OR	ENA

Set all 4 DIP positions of switch S4 to the CLOSED position.

5.3 Test Results

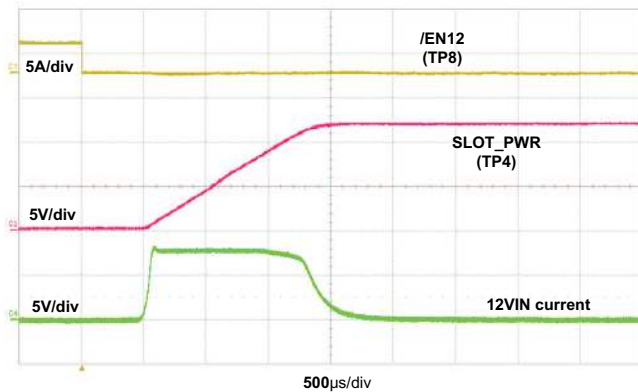

**Figure 3. Output Ramp-Up Waveforms –
SLOT_PWR Rail**

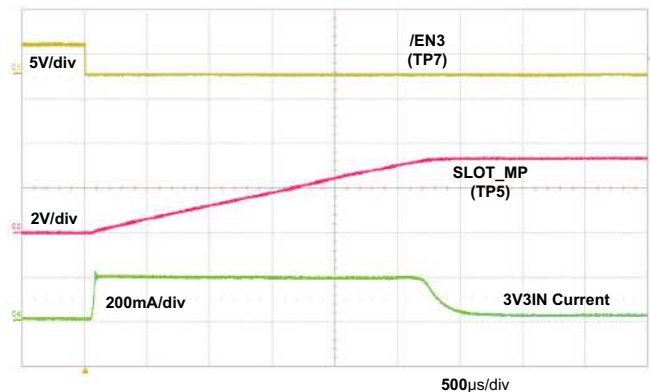

**Figure 4. Output Ramp-Up Waveforms –
SLOT_MP Rail**

6 EVM Feature Details

6.1 Test Points

The TPS2458EVM contains numerous test points throughout the circuit for user monitoring of waveforms and voltage measurement. Table 6 lists the module test points and the signal available at each one. The EVM PCB layout connects all ground nodes and supply returns to a common GND node, via several power plane areas. However, due to potentially high loading conditions on the two Payload Power outputs, multiple ground test points are provided to mitigate the measurement impact of return current drops. Therefore, where appropriate, certain test points are paired in the table with the pertinent reference point for meter return connections

Table 6. Module Test Points

TEST POINT NAME	REF. POINT	SIGNAL NAME	DESCRIPTION
TP1	TP3	12VIN	Input 12 V supply for AdvancedMC™ Slot A
TP2		3V3IN	Input 3.3 V supply for AdvancedMC™ Slot A
TP4	TP6	SLOT_PWR	AdvancedMC™ Payload Power, 12 V output
TP5		SLOT_MP	AdvancedMC™ Management Power, 3.3 V output
TP7	TP27	$\overline{\text{EN3}}$	Active-low enable input to TPS2458 for the 3.3 V rail
TP8		$\overline{\text{EN12}}$	Active-low enable input to the TPS2458 for the 12-V rail
TP9		$\overline{\text{OREN}}$	Channel A OR'ing FET/function enable signal to the TPS2458
TP10	TP11		12-V load current sense voltage
TP12	TP14	PASS	TPS2458 pass FET gate drive output
TP13		BLK	TPS2458 block/OR'ing FET gate drive output
TP16	TP15 TP24 TP27	$\overline{\text{FLT12}}$	Slot A 12-V open-drain, active-low FAULT output indication
TP17		$\overline{\text{PG12}}$	Slot A 12-V open-drain, active-low POWERGOOD output indication
TP18		$\overline{\text{FLT3}}$	Slot A 3.3-V open-drain, active-low FAULT output indication
TP19		$\overline{\text{PG3}}$	Slot A 3.3-V open-drain, active-low POWERGOOD output indication
TP20	TP14	CT3	Timing cap waveform for the 3.3-V rail (SLOT_MP)
TP21		CT12	Timing cap waveform for the 12-V rail (SLOT_PWR)
TP22	TP15 TP24 TP27	SUM12OUT	Expansion current summing output 12.0 V
TP23		SUM3OUT	Expansion current summing output 3.3 V
TP25		SUM12IN	Expansion current summing input 12.0 V
TP26		SUM3IN	Expansion current summing input 3.3 V

On the TPS2458EVM, the device fault ($\overline{\text{FLT}}_x$) and power good ($\overline{\text{PG}}_x$) outputs are all used to drive the STATUS LED's. Power for LED drive is derived from the 3.3-V input supply.

6.2 Connecting Loads to the TPS2458EVM

Each of the power rails of the TPS2458EVM is supplied with some amount of load capacitance in the form of discrete electrolytics. The capacitors can be connected to or disconnected from their associated output nodes using 100-mil, 2-pin shunt jumpers across the on-board PCB headers. These capacitors are intended to simulate input bulk capacitance which may be encountered at the front ends of AdvancedMC™ modules plugged into the card slots of the target application. The AdvancedMC™ standard specifies the maximum allowable input capacitance on both Management and Payload Power rails. The TPS2458EVM provides up to 150 μF capacitance on the Management Power output, according to the AdvancedMC™ maximum limit. The EVM also provides up to 880 μF of capacitance, implemented in increments of 440 μF devices, on the Payload Power rail, to approximate the 800 μF limit of the standard. In addition, low-level (mA) load resistors can be jumpered in across each output and return. These limited load resistors are intended primarily as reset devices between output ramp events, particularly when loaded with significant capacitance.

[Table 7](#) lists the EVM module's output voltage nodes, and for each one indicates the associated jumper reference designators, and the resultant load value with jumper installed.

Table 7. EVM On-Board Loads

OUTPUT RAIL	JUMPER	DEVICE	VALUE
SLOT_MP	J15	C11	150 μF
	J14	R6	270 Ω
SLOT_PWR	J12	C7, C8	440 μF
	J13	C9, C10	440 μF
	J11	R5	1 k Ω

Banana jacks are provided along the right-hand edge of the board for connection of the user's optional test loads. The output banana jack reference designators are listed in [Table 3](#) along with the voltage rail available at each one. Also, the net names are screen printed on the PCB, adjacent to their respective jacks.

7 Assembly Drawing and PCB Layout

The top assembly drawing and individual PCB layers for the TPS2458EVM are shown in the following figures.

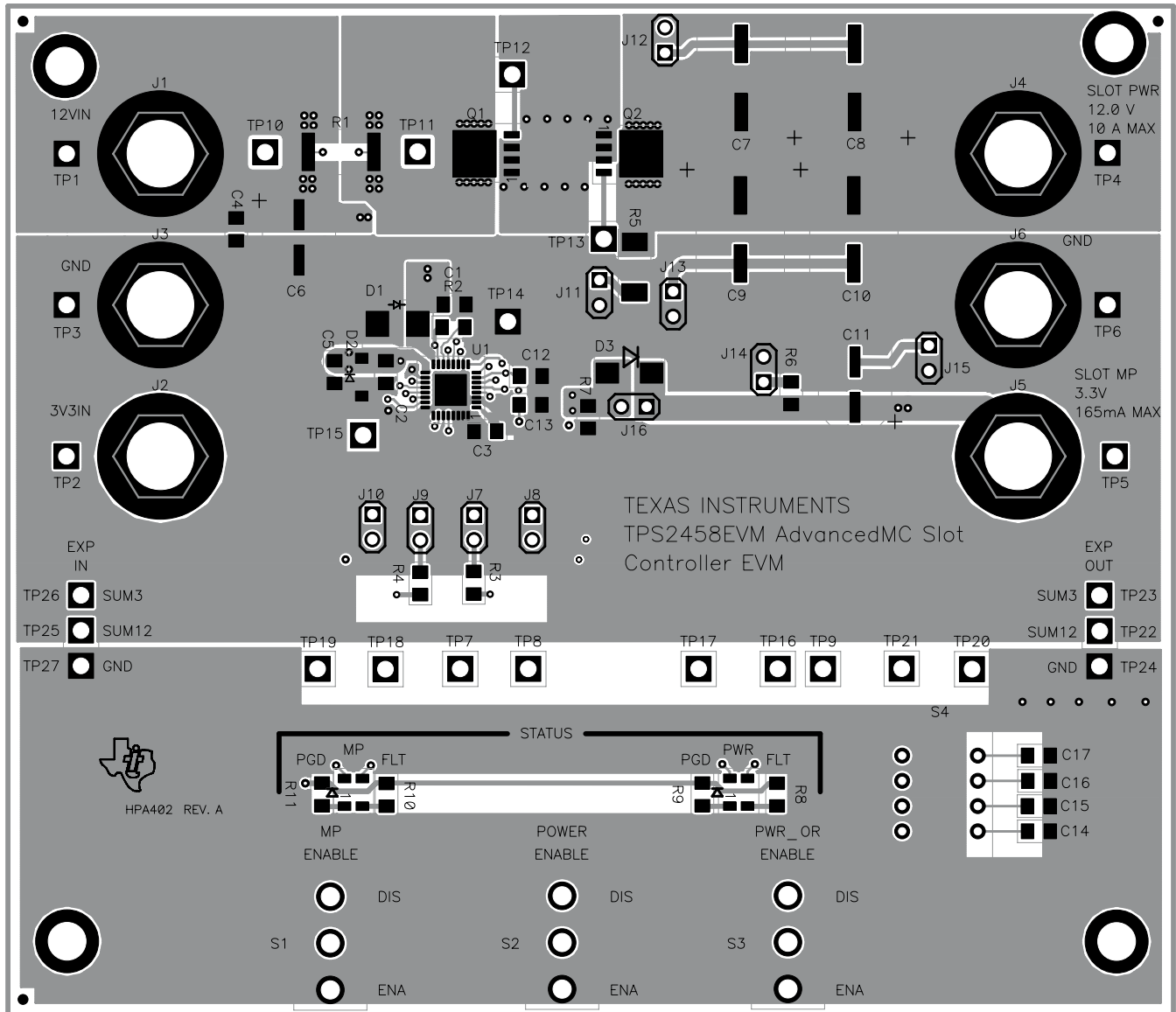

Figure 5. Top Assembly

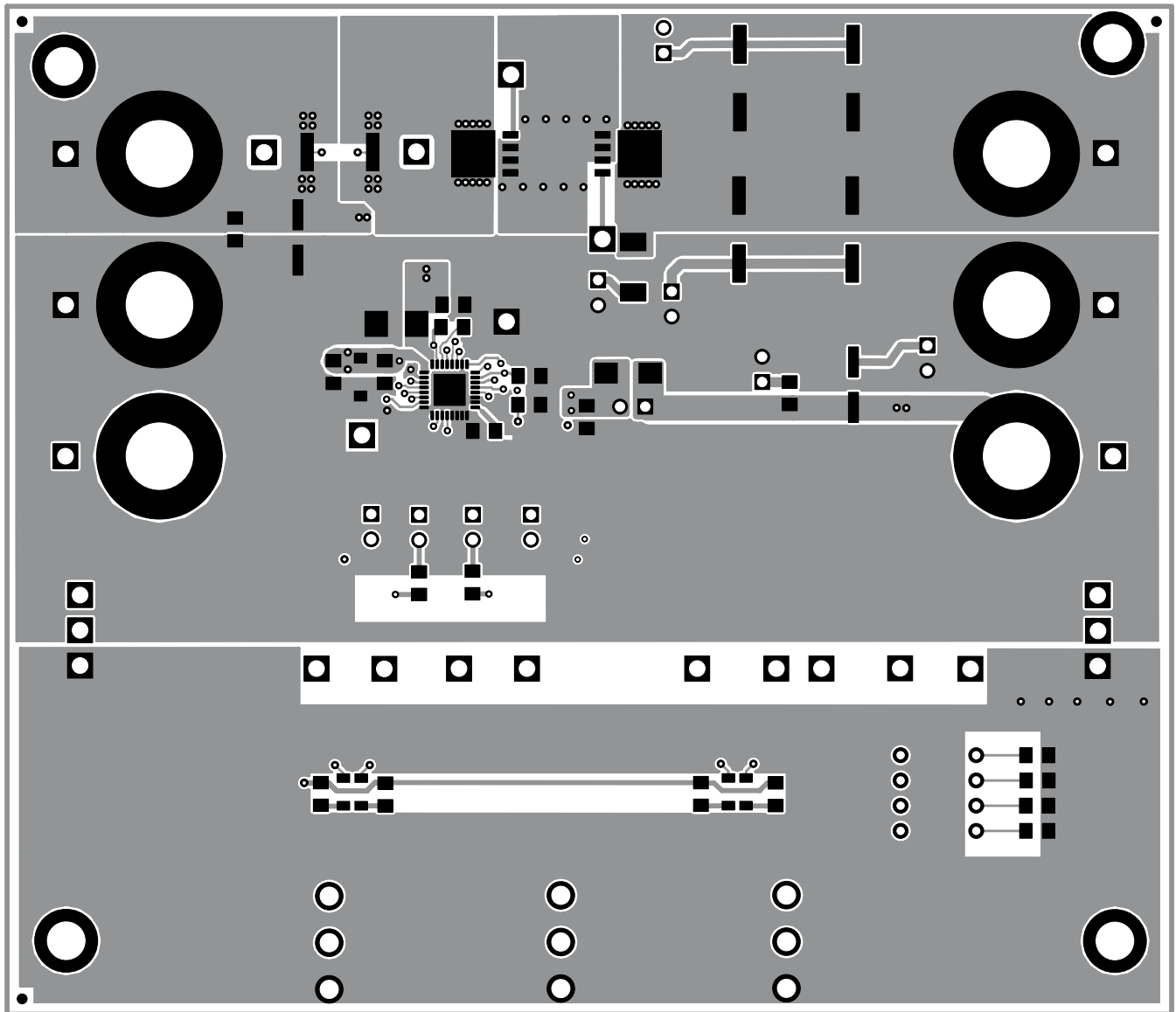

Figure 6. Top Layer Routing

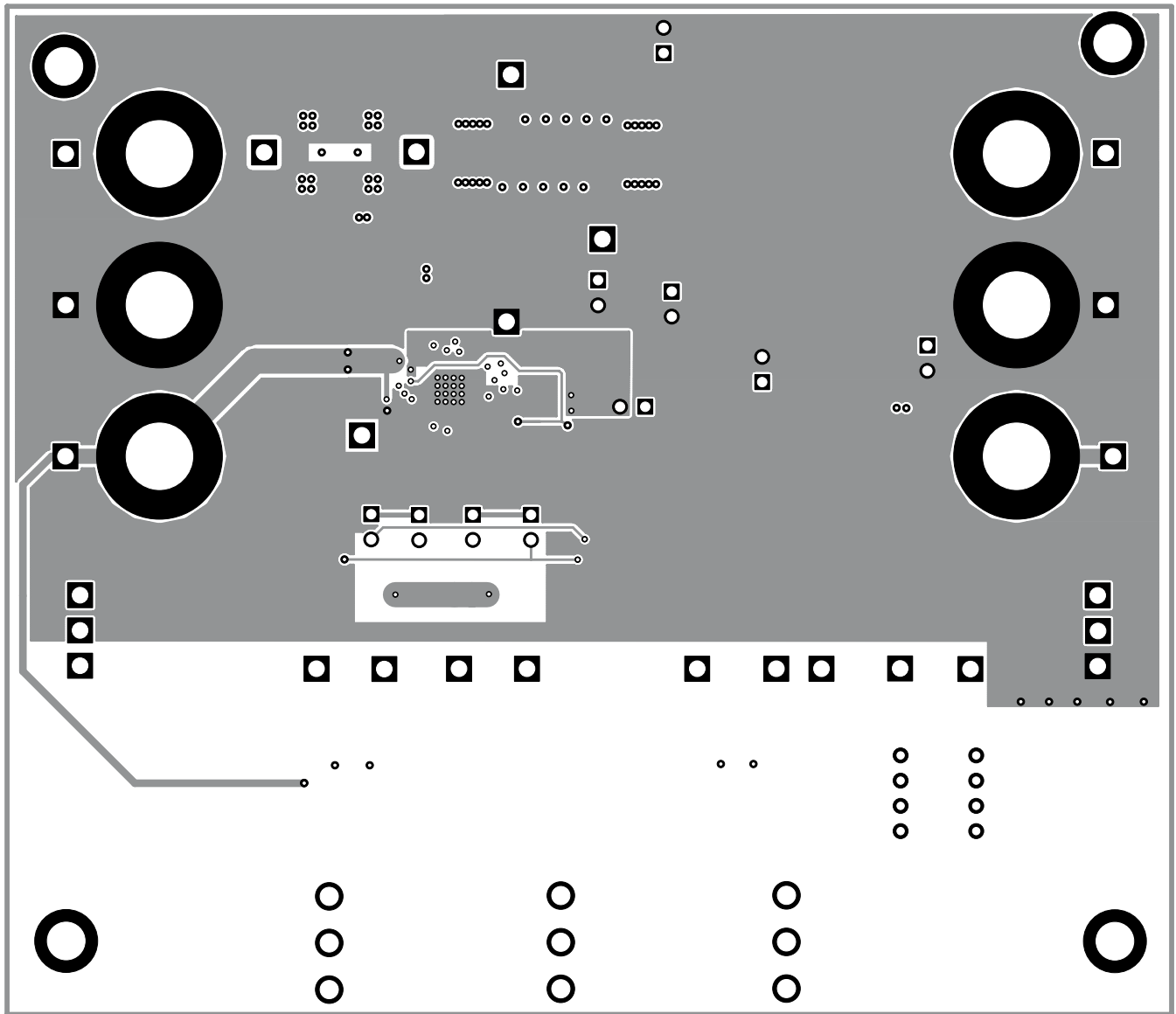

Figure 7. Layer 2 Routing

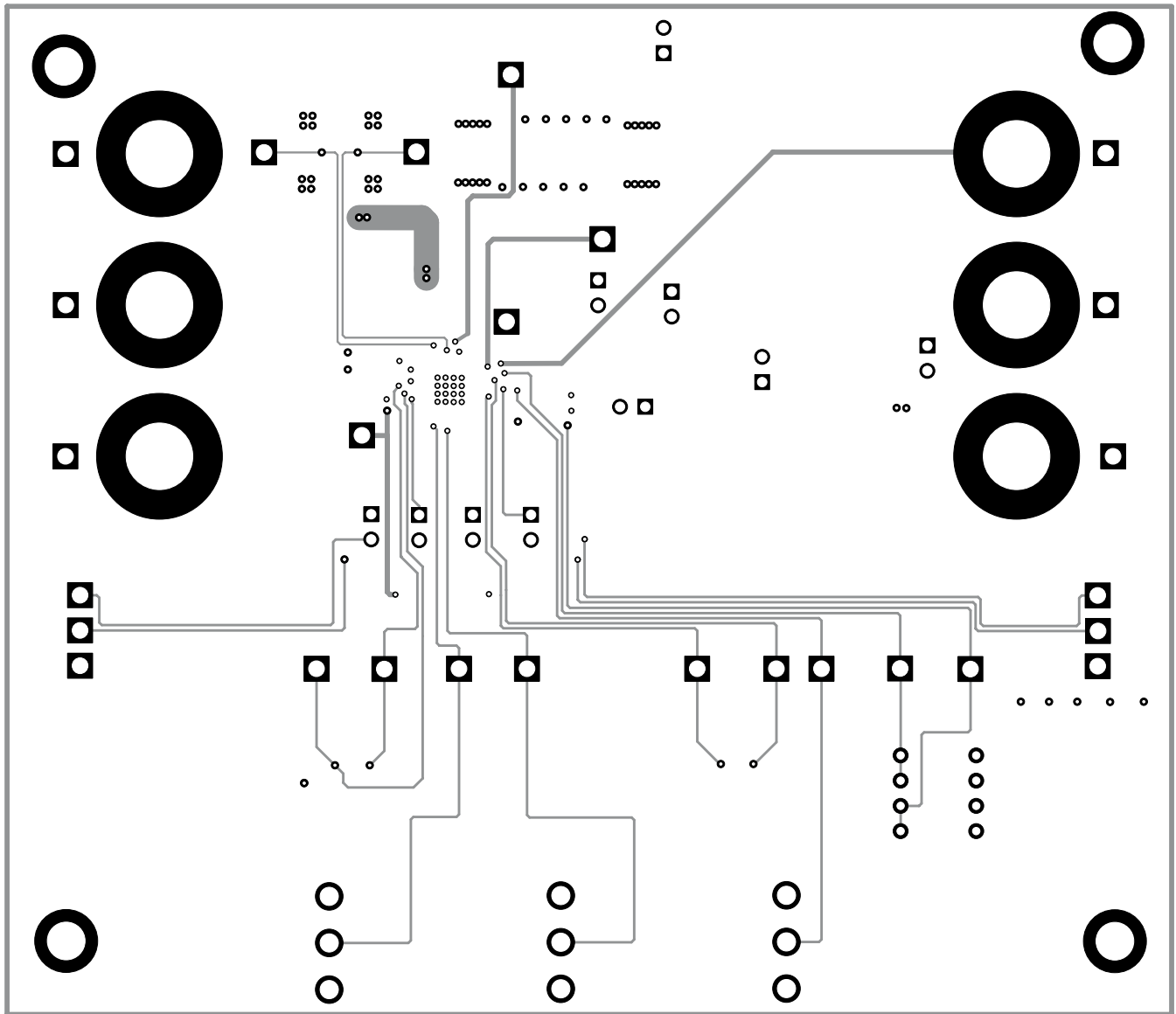

Figure 8. Layer 3 Routing

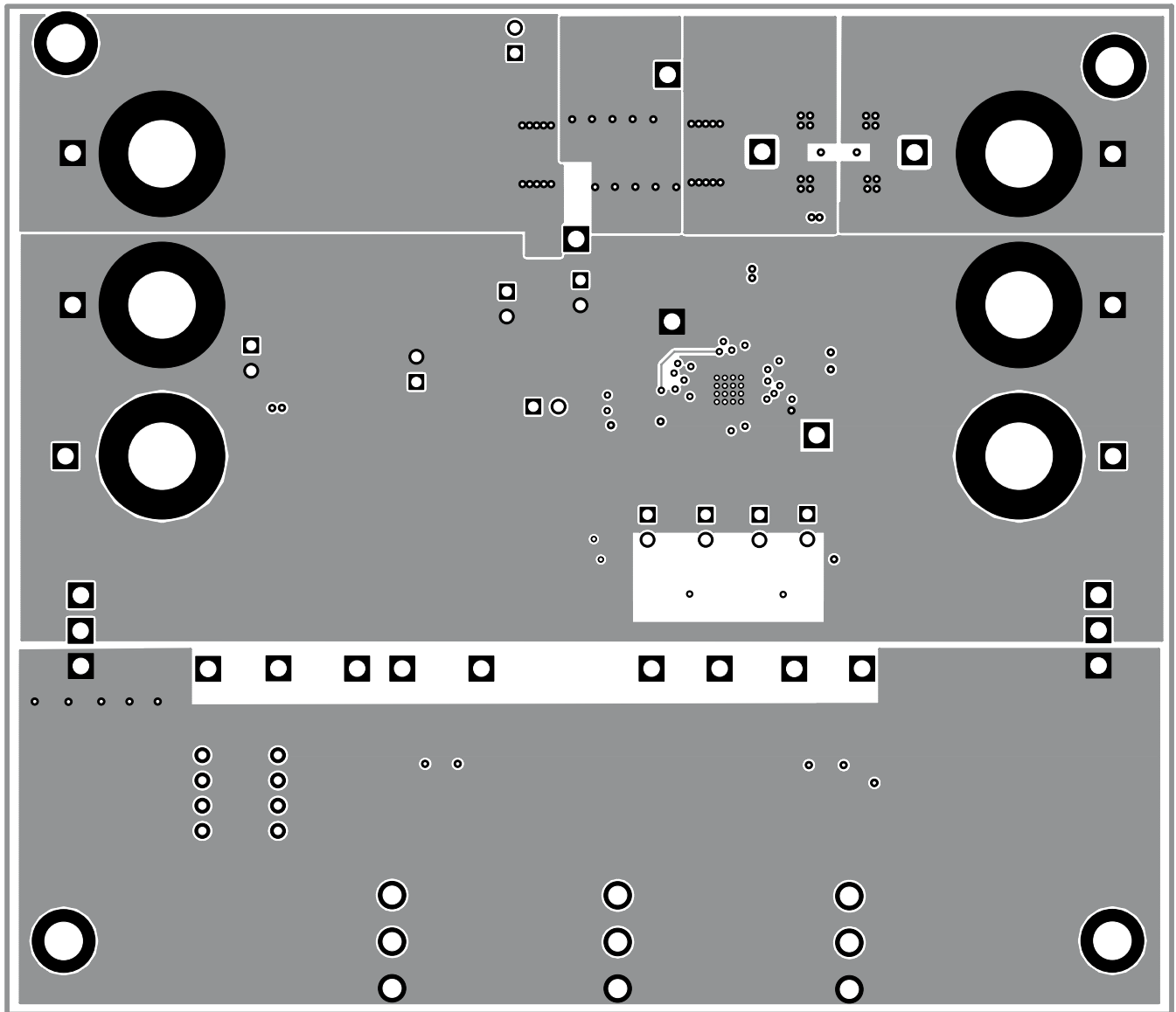

Figure 9. Bottom Layer Routing

8 List of Materials

Table 8. TPS2348 List of Materials⁽¹⁾⁽²⁾⁽³⁾⁽⁴⁾⁽⁵⁾⁽⁶⁾⁽⁷⁾⁽⁸⁾⁽⁹⁾

COUNT	REF DES	DESCRIPTION	PART NUMBER	MFR
3	C1, C2, C3	Capacitor, ceramic, 25 V, X7R, 20%, 0.1 μ F, 0805	Std.	Std.
1	C11	Capacitor, aluminum, SM, 10 V, \pm 20%, 150 μ F, case D	EEV-FK1A151P	Panasonic
1	C12	Capacitor, ceramic, 10 V, X7R, 10%, 0.022 μ F, 0805	Std.	Std.
2	C13, C17	Capacitor, ceramic, 10 V, X7R, 10%, 0.047 μ F, 0805	Std.	Std.
1	C14	Capacitor, ceramic, 10 V, X7R, 10%, 0.1 μ F, 0805	Std.	Std.
0	C15	Capacitor, ceramic, 10 V, X7R, 10%, 0805	Std.	Std.
1	C16	Capacitor, ceramic, 10 V, X7R, 10%, 0.01 μ F, 0805	Std.	Std.
2	C4, C5	Capacitor, ceramic, 25 V, X7R, 20%, 1 μ F, 0805	Std.	Std.
1	C6	Capacitor, aluminum, SM, 25 V, \pm 20%, 47 μ F, Case D	EEV-FK1E470P	Panasonic
4	C7, C8, C9, C10	Capacitor, aluminum, SM, 25 V, \pm 20%, 220 μ F, Case F	EEV-FK1E221P	Panasonic
1	D1	Diode, TVS, V(RWM) = 13.6 V, 600 W pk., SMB	P6SMB16A	"ON Semior Vishayor Littelfuse"
1	D2	Diode, Zener, 4.3 V, 500 mW max., SOD-123	BZT52C4V3	Diodes
1	D3	Diode, Schottky, 1 A, 20 V, SMA	B120	Diodes
2	D4, D5	Diode, LED, red/green, 1210, 45/35 mcd @ 20 mA, 0.126 x 0.106in.	LTST-C155KGJRKT	Lite-On
6	J1, J2, J3, J4, J5, J6	Jack, banana, non-ins., PC mount, TH	3267	Pomona
10	J7, J8, J9, J10, J11, J12, J13, J14, J15, J16	Header, 2 pin, 100-mil spacing, 0.100 in. x 2	PEC36SAAN	Sullins
1	Q1	Transistor, NFET, 30 V, 100A, $R_{DS(on)} < 5$ mohm, TDSO-8	"BSC016N03LSG# #or BSC022N03SG"	Infineon
1	Q2	Transistor, NFET, 30 V, $R_{DS(on)} < 20$ mohm, TDSO-8	"BSC057N03LSG# #or BSC050N03LSGor BSC042N03LSGor BSC022N03SGor BSC016N03LSG"	Infineon

- (1) These assemblies are ESD sensitive, ESD precautions shall be observed.
- (2) These assemblies must be clean and free from flux and all contaminants. Use of no clean flux is not acceptable.
- (3) These assemblies must comply with workmanship standards IPC-A-610 Class 2.
- (4) "TH" package designation indicates "thru-hole" (lead) component.
- (5) Part number information is for reference only to further illustrate component characteristics; substitution of other mfgs' part of equal or better specification is permissible. Substitution NOT allowed on part numbers marked with double asterisk (**).
- (6) Double pound sign ("##") after part number indicates preferred device. Acceptable substitutes are listed afterwards, in decreasing order of preference.
- (7) If banana jacks (J1 - J6) are supplied with solder lugs, dispose of lugs prior to installation on PCB. Solder lugs are NOT to be installed on assembly.
- (8) Spacers to be installed at each of the thru-holes at the four corners of the PCB assembly, using nylon screws.
- (9) Shunts installed in accordance with manufacturing test procedure during test.

Table 8. TPS2348 List of Materials (continued)

COUNT	REF DES	DESCRIPTION	PART NUMBER	MFR
1	R1	Resistor, metal strip, 1 W, 1%, 0.005 Ω , 2512	WSL2512-5L000FEA	Vishay-Dale
1	R2	Resistor, chip, 1/10 W, 1%, 422 Ω , 0805	Std	Std
1	R3	Resistor, chip, 1/10 W, 1%, 6.81 k Ω , 0805	Std	Std
1	R4	Resistor, chip, 1/10 W, 1%, 3.32 k Ω , 0805	Std	Std
1	R5	Resistor, chip, 1/2 W, 5%, 1 k Ω , 2010	Std	Std
1	R6	Resistor, chip, 1/10 W, 5%, 270 Ω , 0805	Std	Std
0	R7	Resistor, chip, 1/10 W, 5%, 0805	Std	Std
4	R8, R9, R10, R11	Resistor, chip, 1/10 W, 5%, 470 Ω , 0805	Std.	Std.
3	S1, S2, S3	Switch, slide, SPDT, vert. act., PC mount, 0.500 x 0.260 in.	"1101M2S3CBE2or 1101M2S3CKE2or 1101M2S3CQE2"	C&K Switch
1	S4	Switch, DIP, 4 pos., raised rocker, 0.38 x 0.48 inch	"76SB04S(T)or BD04"	"Grayhillor C&K Switch"
21	TP1, TP2, TP4, TP5, TP7, TP8, TP9, TP10, TP11, TP12, TP13, TP16, TP17, TP18, TP19, TP20, TP21, TP22, TP23, TP25, TP26	Test point, white, 0.062 in. Hole, 5012, TH	5012	Keystone
6	TP3, TP6, TP14, TP15, TP24, TP27	Test point, black, 0.062 in. Hole, 5011, TH	5011	Keystone
1	U1	AdvancedMC Slot Controller, QFN-32	TPS2458RHB**	Texas Instruments
1	N/A	PCB, FR-4, 4 layer, SMOBC, 4.62" x 4.00" x .062"	HPA402**	Any
8	N/A	Shunt, open top	151-8000	Kobiconn
4	N/A	Spacer, nylon, hex, #6-32, 0.625"	14HTSP020	Eagle
4	N/A	Screw, nylon, round head, #6-32, 0.25"	010632R025	Eagle

EVALUATION BOARD/KIT IMPORTANT NOTICE

Texas Instruments (TI) provides the enclosed product(s) under the following conditions:

This evaluation board/kit is intended for use for **ENGINEERING DEVELOPMENT, DEMONSTRATION, OR EVALUATION PURPOSES ONLY** and is not considered by TI to be a finished end-product fit for general consumer use. Persons handling the product(s) must have electronics training and observe good engineering practice standards. As such, the goods being provided are not intended to be complete in terms of required design-, marketing-, and/or manufacturing-related protective considerations, including product safety and environmental measures typically found in end products that incorporate such semiconductor components or circuit boards. This evaluation board/kit does not fall within the scope of the European Union directives regarding electromagnetic compatibility, restricted substances (RoHS), recycling (WEEE), FCC, CE or UL, and therefore may not meet the technical requirements of these directives or other related directives.

Should this evaluation board/kit not meet the specifications indicated in the User's Guide, the board/kit may be returned within 30 days from the date of delivery for a full refund. **THE FOREGOING WARRANTY IS THE EXCLUSIVE WARRANTY MADE BY SELLER TO BUYER AND IS IN LIEU OF ALL OTHER WARRANTIES, EXPRESSED, IMPLIED, OR STATUTORY, INCLUDING ANY WARRANTY OF MERCHANTABILITY OR FITNESS FOR ANY PARTICULAR PURPOSE.**

The user assumes all responsibility and liability for proper and safe handling of the goods. Further, the user indemnifies TI from all claims arising from the handling or use of the goods. Due to the open construction of the product, it is the user's responsibility to take any and all appropriate precautions with regard to electrostatic discharge.

EXCEPT TO THE EXTENT OF THE INDEMNITY SET FORTH ABOVE, NEITHER PARTY SHALL BE LIABLE TO THE OTHER FOR ANY INDIRECT, SPECIAL, INCIDENTAL, OR CONSEQUENTIAL DAMAGES.

TI currently deals with a variety of customers for products, and therefore our arrangement with the user **is not exclusive**.

TI assumes **no liability for applications assistance, customer product design, software performance, or infringement of patents or services described herein.**

Please read the User's Guide and, specifically, the Warnings and Restrictions notice in the User's Guide prior to handling the product. This notice contains important safety information about temperatures and voltages. For additional information on TI's environmental and/or safety programs, please contact the TI application engineer or visit www.ti.com/esh.

No license is granted under any patent right or other intellectual property right of TI covering or relating to any machine, process, or combination in which such TI products or services might be or are used.

FCC Warning

This evaluation board/kit is intended for use for **ENGINEERING DEVELOPMENT, DEMONSTRATION, OR EVALUATION PURPOSES ONLY** and is not considered by TI to be a finished end-product fit for general consumer use. It generates, uses, and can radiate radio frequency energy and has not been tested for compliance with the limits of computing devices pursuant to part 15 of FCC rules, which are designed to provide reasonable protection against radio frequency interference. Operation of this equipment in other environments may cause interference with radio communications, in which case the user at his own expense will be required to take whatever measures may be required to correct this interference.

EVM WARNINGS AND RESTRICTIONS

It is important to operate this EVM within the input voltage range of 3.0 V to 12 V and the output voltage range of 3.0 V to 12 V .

Exceeding the specified input range may cause unexpected operation and/or irreversible damage to the EVM. If there are questions concerning the input range, please contact a TI field representative prior to connecting the input power.

Applying loads outside of the specified output range may result in unintended operation and/or possible permanent damage to the EVM. Please consult the EVM User's Guide prior to connecting any load to the EVM output. If there is uncertainty as to the load specification, please contact a TI field representative.

During normal operation, some circuit components may have case temperatures greater than 85°C. The EVM is designed to operate properly with certain components above as long as the input and output ranges are maintained. These components include but are not limited to linear regulators, switching transistors, pass transistors, and current sense resistors. These types of devices can be identified using the EVM schematic located in the EVM User's Guide. When placing measurement probes near these devices during operation, please be aware that these devices may be very warm to the touch.

Mailing Address: Texas Instruments, Post Office Box 655303, Dallas, Texas 75265
Copyright © 2009, Texas Instruments Incorporated

IMPORTANT NOTICE

Texas Instruments Incorporated and its subsidiaries (TI) reserve the right to make corrections, modifications, enhancements, improvements, and other changes to its products and services at any time and to discontinue any product or service without notice. Customers should obtain the latest relevant information before placing orders and should verify that such information is current and complete. All products are sold subject to TI's terms and conditions of sale supplied at the time of order acknowledgment.

TI warrants performance of its hardware products to the specifications applicable at the time of sale in accordance with TI's standard warranty. Testing and other quality control techniques are used to the extent TI deems necessary to support this warranty. Except where mandated by government requirements, testing of all parameters of each product is not necessarily performed.

TI assumes no liability for applications assistance or customer product design. Customers are responsible for their products and applications using TI components. To minimize the risks associated with customer products and applications, customers should provide adequate design and operating safeguards.

TI does not warrant or represent that any license, either express or implied, is granted under any TI patent right, copyright, mask work right, or other TI intellectual property right relating to any combination, machine, or process in which TI products or services are used. Information published by TI regarding third-party products or services does not constitute a license from TI to use such products or services or a warranty or endorsement thereof. Use of such information may require a license from a third party under the patents or other intellectual property of the third party, or a license from TI under the patents or other intellectual property of TI.

Reproduction of TI information in TI data books or data sheets is permissible only if reproduction is without alteration and is accompanied by all associated warranties, conditions, limitations, and notices. Reproduction of this information with alteration is an unfair and deceptive business practice. TI is not responsible or liable for such altered documentation. Information of third parties may be subject to additional restrictions.

Resale of TI products or services with statements different from or beyond the parameters stated by TI for that product or service voids all express and any implied warranties for the associated TI product or service and is an unfair and deceptive business practice. TI is not responsible or liable for any such statements.

TI products are not authorized for use in safety-critical applications (such as life support) where a failure of the TI product would reasonably be expected to cause severe personal injury or death, unless officers of the parties have executed an agreement specifically governing such use. Buyers represent that they have all necessary expertise in the safety and regulatory ramifications of their applications, and acknowledge and agree that they are solely responsible for all legal, regulatory and safety-related requirements concerning their products and any use of TI products in such safety-critical applications, notwithstanding any applications-related information or support that may be provided by TI. Further, Buyers must fully indemnify TI and its representatives against any damages arising out of the use of TI products in such safety-critical applications.

TI products are neither designed nor intended for use in military/aerospace applications or environments unless the TI products are specifically designated by TI as military-grade or "enhanced plastic." Only products designated by TI as military-grade meet military specifications. Buyers acknowledge and agree that any such use of TI products which TI has not designated as military-grade is solely at the Buyer's risk, and that they are solely responsible for compliance with all legal and regulatory requirements in connection with such use.

TI products are neither designed nor intended for use in automotive applications or environments unless the specific TI products are designated by TI as compliant with ISO/TS 16949 requirements. Buyers acknowledge and agree that, if they use any non-designated products in automotive applications, TI will not be responsible for any failure to meet such requirements.

Following are URLs where you can obtain information on other Texas Instruments products and application solutions:

Products

Amplifiers	amplifier.ti.com
Data Converters	dataconverter.ti.com
DLP® Products	www.dlp.com
DSP	dsp.ti.com
Clocks and Timers	www.ti.com/clocks
Interface	interface.ti.com
Logic	logic.ti.com
Power Mgmt	power.ti.com
Microcontrollers	microcontroller.ti.com
RFID	www.ti-rfid.com
RF/IF and ZigBee® Solutions	www.ti.com/lprf

Applications

Audio	www.ti.com/audio
Automotive	www.ti.com/automotive
Broadband	www.ti.com/broadband
Digital Control	www.ti.com/digitalcontrol
Medical	www.ti.com/medical
Military	www.ti.com/military
Optical Networking	www.ti.com/opticalnetwork
Security	www.ti.com/security
Telephony	www.ti.com/telephony
Video & Imaging	www.ti.com/video
Wireless	www.ti.com/wireless

Mailing Address: Texas Instruments, Post Office Box 655303, Dallas, Texas 75265
Copyright © 2009, Texas Instruments Incorporated