

THIS DRAWING IS UNPUBLISHED. RELEASED FOR PUBLICATION  
 © COPYRIGHT - TE Connectivity Ltd. ALL RIGHTS RESERVED.

REVISIONS				
P	LTR	DESCRIPTION	DATE	APVD
K		REVISED PER ECO-18-007011	25MAY2018	KH MZ

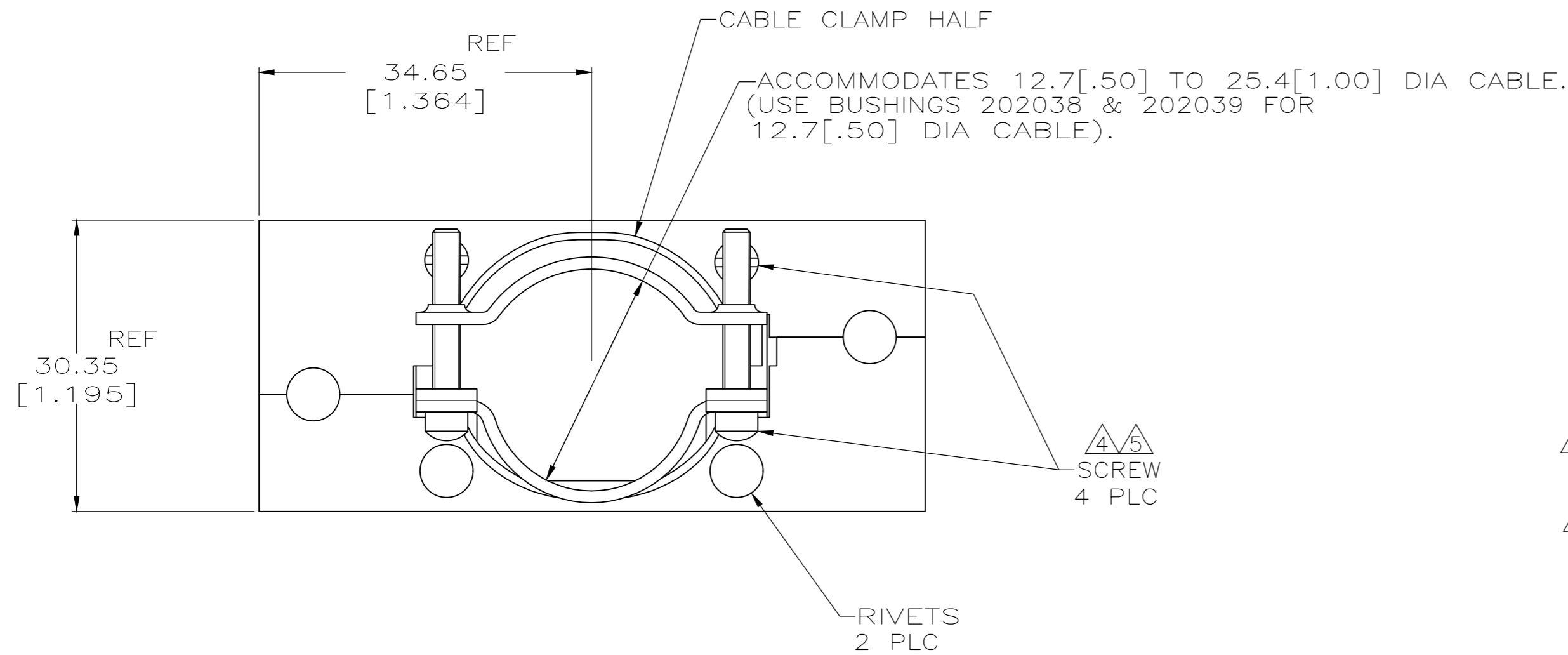

- ① SHIELD HALF, TWO PIECE, CABLE CLAMP HALF, RIVET AND SCREW: CARBON STEEL. CABLE CLAMP FIXED: STAINLESS STEEL.
- ② SHIELD HALF, TWO PIECE AND CABLE CLAMP HALF: 5.08um [.000200] MIN NICKEL. SCREW: 3.81um [.000150] MIN ZINC. RIVET: NICKEL.
- 3. TWO PVC SLEEVES FOR INSULATION OF JACKSCREWS TO BE PACKAGED WITH ASSEMBLY.
- ④ ZINC PLATING WITH HEXAVALENT CHROMATE COATING.
- ⑤ ZINC PLATING WITHOUT HEXAVALENT CHROMATE COATING.

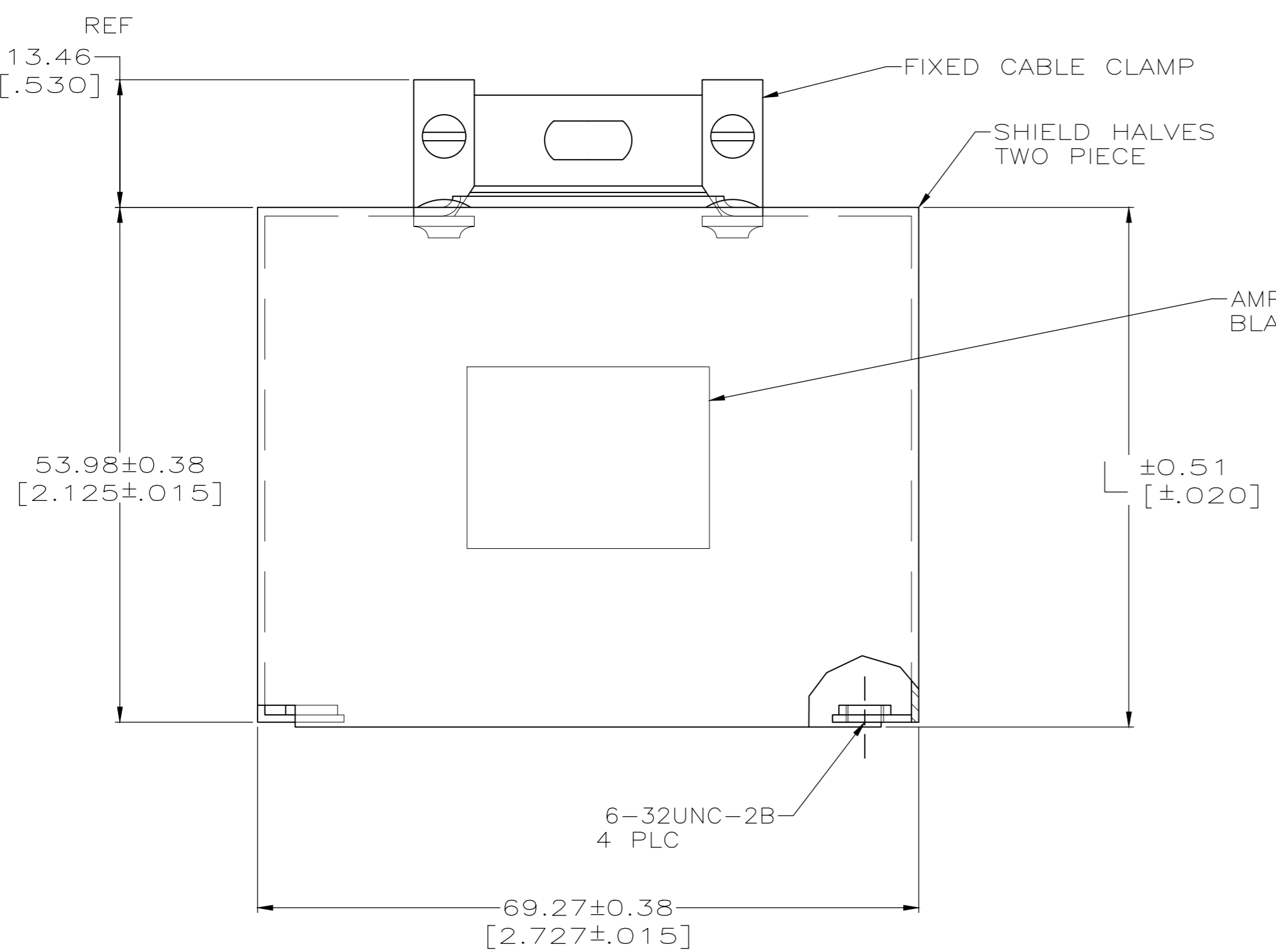

⑤	71.04 [2.797]	202713-7
⑤	53.98 [2.125]	202713-6
-	-	202713-5
-	-	202713-4
-	-	202713-3
④	71.04 [2.797]	202713-2
④	53.98 [2.125]	202713-1
SCREW FINISH	L	PART NUMBER

THIS DRAWING IS A CONTROLLED DOCUMENT.		DWN C.OBERMAN 05/26/95	<b>STE</b> TE Connectivity Ltd.	
DIMENSIONS: mm [INCHES]		CHK R.STONE 6-1-95		
TOLERANCES UNLESS OTHERWISE SPECIFIED:		APVD G.STEINHAUER 6-5-95	NAME TWO PIECE SHIELD ASSEMBLY, 75 POSITION, M SERIES	
0 PLC ± -		PRODUCT SPEC -	SIZE CAGE CODE DRAWING NO RESTRICTED TO	
1 PLC ± -		APPLICATION SPEC -	A2 00779 C=202713	
2 PLC ± -		WEIGHT 0.000000	SCALE 2:1 SHEET 1 OF 1 REV K	
3 PLC ± -		CUSTOMER DRAWING		
4 PLC ± -				
ANGLES ± -				
FINISH - ①				