

90168-AS

SOLDER CUP SPRING LOADED CONTACT

Visit us at WWW.PRECI-DIP.COM



preci-dip

Engineered for Success

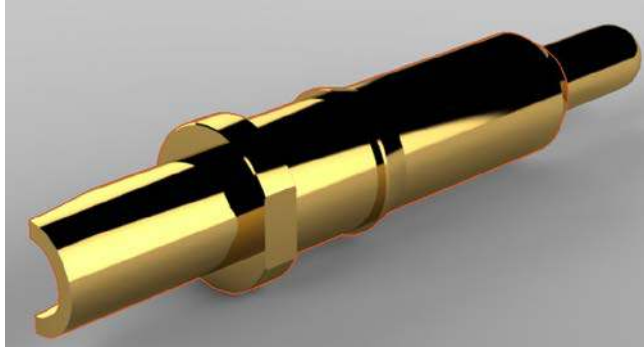

Assembly: Solder Cup
Overall Length:
10.5mm (.413")
Stroke: 1.6mm (.063")

**ORDER AS:
90168-AS**

APPLICATION NOTES:

PRODUCT DESCRIPTION:

Preci-Dip Spring Loaded contact with solder cup for wire attachment. Every Preci-Dip spring contact is Swiss precision machined and assembled for highest quality, performance and long product life.

PRODUCT PACKAGING:

This product is sold in bulk. It can be provided assembled in an insulator. Let us help you with your custom packaging request.

HOW TO USE THIS PRODUCT:

This product is ideal for attaching wire. With solid one-piece body construction, These spring loaded contact are typically used in docking stations, recharging stations, module stacking and pluggable SLC requirements.

CAN I CUSTOMIZE THIS PRODUCT?

Preci-Dip welcomes custom design requests. Please provide us your spring force and packaging requirements. Call today to discuss your application.

Temperature rise [°C]

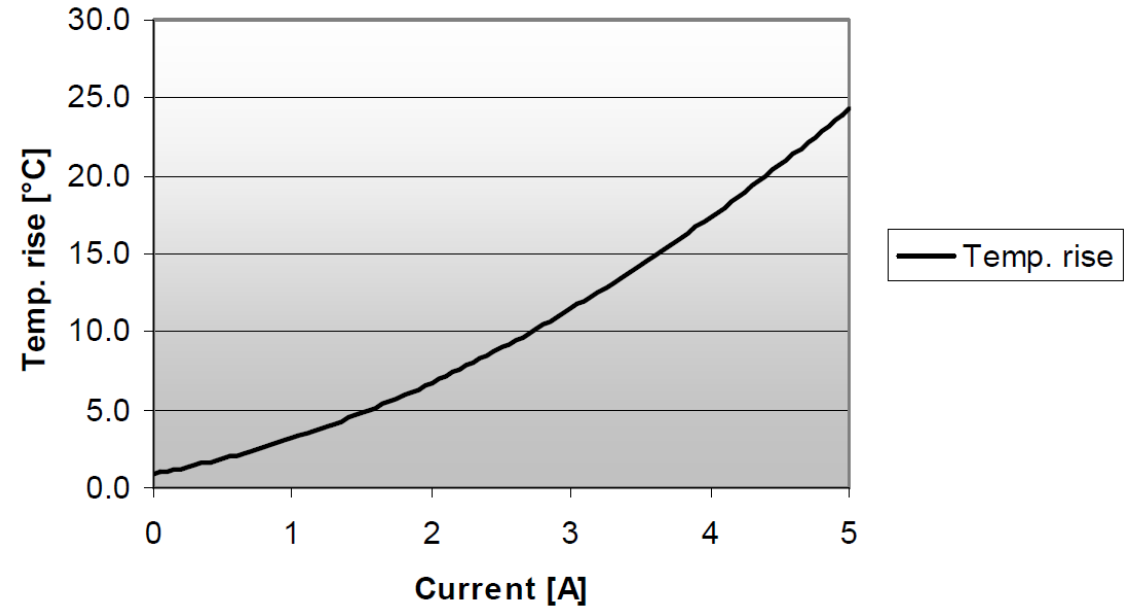

Current: 3A continuous @ 10 ° C rise

Wire termination

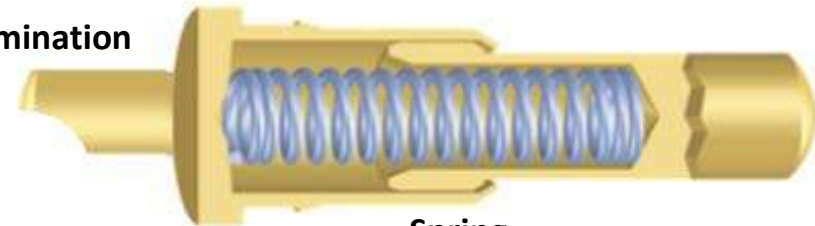

Piston

Spring

HOW IT WORKS:

Strong, secure and featuring one piece solid body construction, there are no capped components at the bottom of this spring contact. No seams for solder to wick inside the shell.



90168-AS

SOLDER CUP SPRING LOADED CONTACT

Visit us at WWW.PRECI-DIP.COM



preci-dip

SPECIFICATIONS:

MATERIAL:

Piston: Brass Alloy, plated 0.38um (15μ") Gold
Barrel: Brass Alloy, plated 0.38um (15μ") Gold
Spring: Stainless Steel

ELECTRICAL:

Current: 3A continuous @ @ 10 ° C rise. 5A Peak.
Rated Voltage: 100Vrms 150Vdc
Contact Resistance: 20mΩ max..

ENVIRONMENTAL

Operating Temperature: -55 to 125° C
Passed Vibration Test Sinusoidal per IEC 512.6d / IEC 68-2-6
Passed Shock Test per IEC 512.6d / IEC 68-2-27
No electrical discontinuity greater than 1μs.

SPRING CONTACT FEATURES:

- * Swiss Experience
- * Swiss Quality
- * Swiss precision machined components
- * Seamless shell construction
- * Press-fit barb on barrel for packaging
- * Gold plating for corrosion resistance.
- * Smooth piston travel
- * High quality, smooth surface finish on tip of piston.
- * Strong and durable construction
- * RoHs

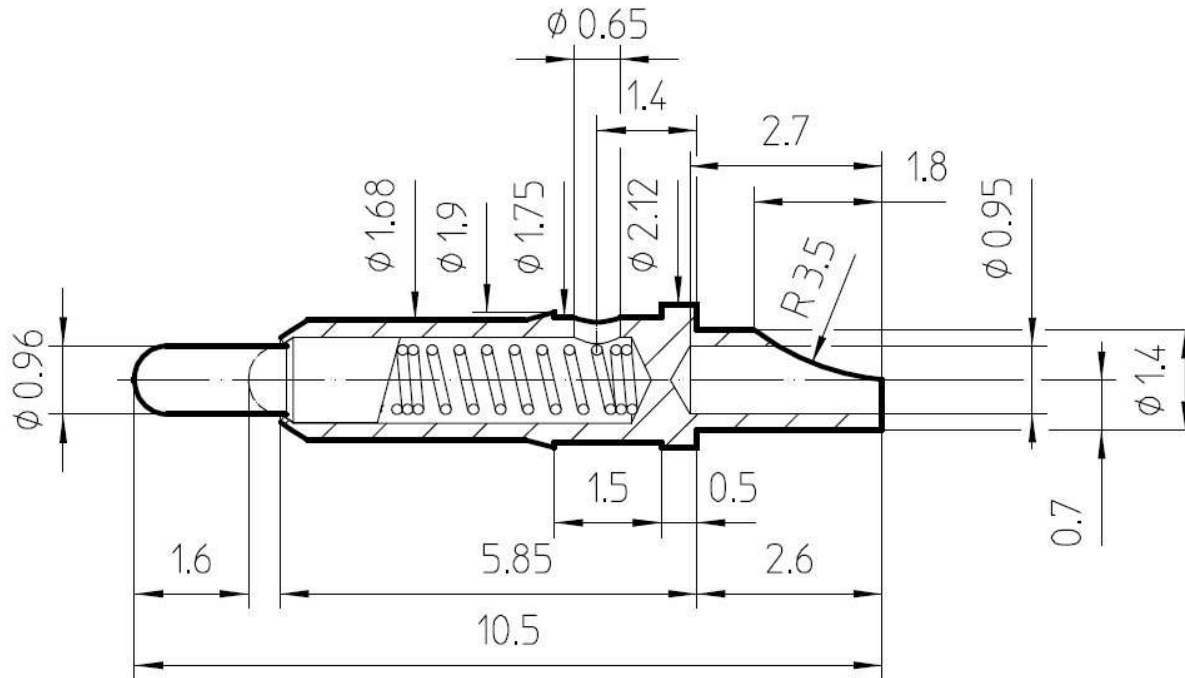

MECHANICAL

Durability: Minimum 40,000 cycles.
Stroke: 1.6mm (.063")

Force: Initial .35N
Half-Stroke 1.1N

HOW TO CUSTOMIZE A SPRING CONTACT:

Specify:

1. Stacking distance between boards
2. Desired piston stroke
3. Desired spring force
4. Desired current rating.
5. Termination style SMT, Solder tail, Wire
6. Desired Cycle life

This product can be assembled in a custom insulator. Please inquire if interested.

