

INA186EVM

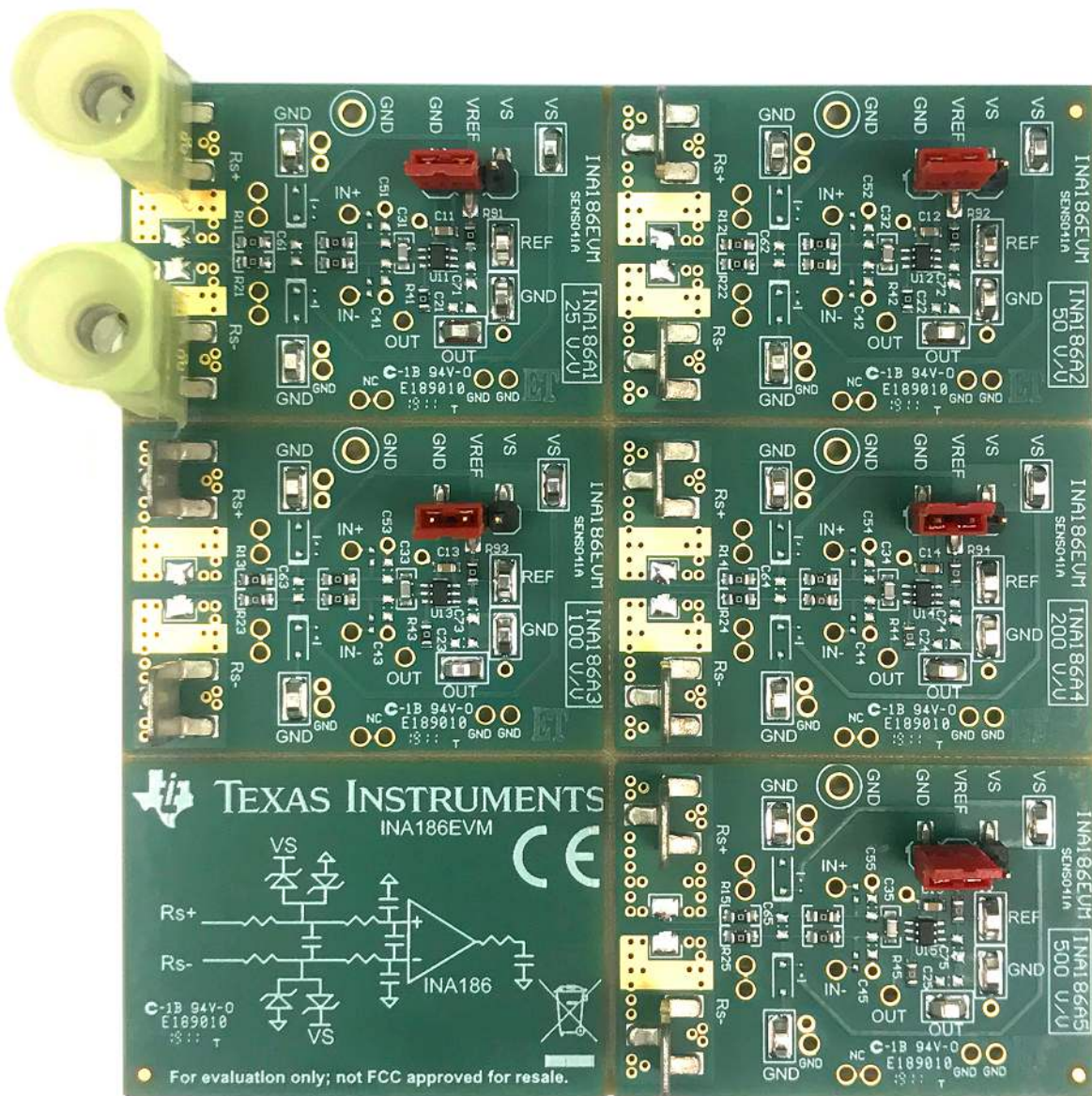

This user's guide describes the characteristics, operation, and use of the INA186 evaluation module (EVM). This EVM is designed to evaluate the performance of the INA186 voltage-output, current shunt monitor in a variety of configurations. Throughout this document, the terms evaluation board, evaluation module, and EVM are synonymous with the INA186EVM. This document also includes a schematic, reference printed-circuit board (PCB) layouts, and a complete bill of materials (BOM).

Contents

1	Overview	3
1.1	EVM Kit Contents	3
1.2	Related Documentation From Texas Instruments	3
2	Hardware	4
2.1	Features	4
3	Operation	4
3.1	Quick Start Setup	4
3.2	Measurements	5
4	EVM Components	6
4.1	R1x, R2x, R4x, R7x, R8x, R9x, C2x, C3x, C4x, C5x, C6x, and C7x	6
4.2	C1x	6
4.3	R3x	6
4.4	R5x, R6x	6
4.5	D1x, D2x, D3x, D4x	6
4.6	S0x, S1x, S2x, S3x, S4x, S5x, S5x, S7x, S8x, S9x, S10x, S11x, S12x	6
4.7	U1x - INA186	7
4.8	J0x, J1x	7
5	Schematic, PCB Layout, and Bill of Materials	8
5.1	Schematics	8
5.2	PCB Layout	13
5.3	Bill of Materials	15

List of Figures

1	INA186EVM Schematic: Gain A1 Panel	8
2	INA186EVM Schematic: Gain A2 Panel	9
3	INA186EVM Schematic: Gain A3 Panel	10
4	INA186EVM Schematic: Gain A4 Panel	11
5	INA186EVM Schematic: Gain A5 Panel	12
6	INA186EVM Top Overlay	13
7	INA186EVM Bottom Overlay	13
8	INA186EVM Top Layer	13
9	INA186EVM Bottom Layer	13
10	INA186EVM Top Solder	13
11	INA186EVM Bottom Solder	13
12	INA186EVM Drill Drawing	14

List of Tables

1	Gain Option Summary	3
2	EVM Kit Contents	3
3	Related Documentation	3
4	Bill of Materials	15

Trademarks

All trademarks are the property of their respective owners.

1 Overview

The INA186 device is a voltage-output, high- and low-side, bidirectional measurement current sense amplifier with a reference pin in an SC70-6 (DCK) package. As shown in [Table 1](#), the INA186 has gains that range from 25 V/V to 500 V/V, depending on the gain option that is selected. The voltage developed across the device inputs is amplified by the corresponding gain of the specific device, and is presented at the output pin. The device accurately senses voltage drops across shunts at common-mode voltages from -0.1 V to $+40\text{ V}$, independent of supply voltages. The device operates and survives common-mode voltages from -0.3 V to $+42\text{ V}$. The device operates with supply voltages between 1.7 V and 5.5 V , and draws a maximum of $65\text{ }\mu\text{A}$ at room temperature. The low offset of the zero-drift architecture enables sensing of very-small differential input voltages, which helps widen the usable input dynamic range and minimize power dissipation in the shunt resistor. Unlike many current sense amplifiers, the INA186 has a very low input bias current, and thus, can easily measure microamps of current.

Table 1. Gain Option Summary

Product	Gain (V/V)
INA186A1	25
INA186A2	50
INA186A3	100
INA186A4	200
INA186A5	500

1.1 EVM Kit Contents

[Table 2](#) summarizes the contents of the INA186EVM kit. Contact the [Texas Instruments Product Information Center](#) nearest you if any component is missing. TI also recommends checking the [INA186 device product folder](#) at www.ti.com for any further information regarding this product.

Table 2. EVM Kit Contents

Item	Item Part Number	Quantity
INA186EVM test board	INA186EVM	1
Quick Connect Receptacle 10-12AWG, 0.250"	4-520448-2	2
Jumper (Shunt Connector) 2POS	2-881545-2	5

1.2 Related Documentation From Texas Instruments

This document provides information regarding Texas Instruments' integrated circuits used in the assembly of the INA186EVM.

Table 3. Related Documentation

Document	Literature Number
INA186 product data sheet	SBOS318

2 Hardware

The INA186EVM is intended to provide basic functional evaluation of the INA186. The fixture layout is not intended to be a model for the target circuit, nor is it laid out for electromagnetic compatibility (EMC) testing. The INA186EVM consists of one PCB with an option to cut out five individual PCBs, one for each of the five gain options (A1 to A5) listed in [Table 1](#). Each of the PCB cutouts consists of one INA186Ax device (where x is 1, 2, 3, 4, or 5), and test points and sockets for external hardware connections, as well as pads to solder down optional circuitry.

2.1 Features

The INA186EVM PCB provides the following features:

- Evaluation of all gain options through provided device boards
- Ease of access to device pins with test points
- Pads and sockets for optional filtering at the input pins and output pin
- Pads for optional input protection devices (TVS or Zener diodes)
- Multiple input signal options, including a method to solder the shunt resistor (0603, 0805, 1206) and safely measure current up to 15 A.

See the device data sheet listed in [Table 3](#) for comprehensive information about the INA186 and the available gain options.

3 Operation

3.1 Quick Start Setup

Follow these procedures to set up and use one of the panels of the INA186EVM. For the following instructions, x = 1, 2, 3, 4, or 5, depending on the selected gain option.

- Step 1. Choose the desired gain option panel.
- Step 2. Make sure the J3x header for the reference (REF) pin is set to the appropriate voltage. Use the included two-position jumper to short header pins 1 (GND) and 2 (REF) for unidirectional current sensing. REF can be connected to VS for unidirectional applications only if the input differential voltage is negative. If bidirectional current sensing is required, then connect the REF pin to an external dc voltage source that is set to a voltage between GND and supply voltage V_S .
- Step 3. Connect an external dc supply voltage (between 1.7 V and 5.5 V) to one of the VS test points (TP3x), and connect the ground reference of that supply to a GND test point (TP4x, TP6x, or TP7x) on the same gain variant panel.
- Step 4. Provide a differential input voltage signal to Rs+ and Rs- by connecting the signal leads to the J0x and J1x quick-fit tabs on the EVM. This connection is explained in [Section 3.2](#).

3.2 Measurements

The INA186EVM allows the user to either emulate the voltage developed across a sense resistor based on a given set of system conditions, or to connect the device inputs to an external shunt. Optionally, a surface-mount technology (SMT) shunt resistor can be soldered across the Rs+ and Rs– pads, and these inputs can be connected in series with the external system and load. Onboard sockets allow for a through-hole shunt resistor to be inserted between S0x and S1x, given that the following socket pairs are shorted with wire jumper: S4x-S5x and S1x-S2x, where x = 1, 2, 3, 4, or 5.

To configure a measurement evaluation *without* a shunt resistor, follow this procedure:

1. Connect a positive differential voltage across the Rs+ (J0x) and Rs– (J1x) tabs. If REF is shorted to GND, then make sure that the Rs+ voltage is the more positive of the two inputs. The input sense voltage must be less than V_s / Gain , or else the amplifier output saturates.
2. Additionally, if the differential voltage supply is a floating supply, connect a –0.1-V to +40-V common-mode voltage to the inputs by connecting the positive lead of the external voltage source to the Rs– (J1x) tab, and source ground to a GND test point. This action effectively raises the absolute common-mode voltage of the input pins, while still retaining a positive input differential signal.
3. Measure the output voltage at the OUT test point (TP5x) with respect to GND. If using the EVM in a bidirectional application, then measure the gained-up shunt voltage at the OUT pin with respect to the REF pin.

To configure a measurement evaluation *with* a shunt resistor, follow this procedure:

1. Solder a 0603 to 1206 resistor at the R3x pads that connect the Rs+ (J0x) and Rs– (J1x) tabs.
2. Connect the Rs+ (J0x) and Rs– (J1x) tabs in series with the load and bus voltage sources while powered off.

WARNING

If measuring current, first make sure that the equipment (shunt resistor, wires, connectors, and so on) can support the amperage and power dissipation. Second, make sure that the current flowing through J0x and J1x does not exceed 15 A. Failure to do so can result in hot surfaces (> 55°C), damage to the EVM, or personal injury.

3. Set the REF pin to GND for unidirectional use, or to a voltage between GND and VS for bidirectional use.
4. Power on the system and measure the output voltage at the OUT test point (TP5x). The output voltage (VOUT) with respect to REF pin is equal to the gain of the device multiplied by the differential voltage measured directly at the device input pins. VOUT measured with respect to GND is equal to the REF voltage plus the gained up differential sense voltage.

4 EVM Components

This section summarizes the INA186EVM components. For the following components, x = 1, 2, 3, 4, or 5, depending on the selected gain option.

4.1 R1x, R2x, R4x, R7x, R8x, R9x, C2x, C3x, C4x, C5x, C6x, and C7x

R1x, R2x, R4x, R7x, R8x, and R9x are factory-installed 0- Ω 0603 resistors.

C2x, C3x, C4x, C5x, C6x, and C7x are not populated except for C3x.

Collectively, these pads allow for user-defined filters for the input pins (IN+ and IN-), the reference pin (REF), and the output pin (OUT) of INA186. If a filter is desired, remove these resistors, replace them with $> 0\text{-}\Omega$ SMT resistors, and populate the capacitor pads with capacitors. Additionally, these resistors can limit current for clamping diodes D4x, D3x, D2x, and D1x during overvoltage events. Additional information regarding the use of input filtering and input protection is provided in the [INA186data sheet](#).

4.2 C1x

C1x is a 0.1- μF , power-supply bypass capacitor.

4.3 R3x

R3x is unpopulated, but allows a surface-mount shunt resistor to be soldered down in between the Rs+ and Rs- pads, which are sensed by the IN+ and IN- input pins. If used, make sure R3x has proper power dissipation for the user-set current load. The chosen resistor must at a minimum have a 0603 Imperial footprint.

4.4 R5x, R6x

R5x and R6x are unpopulated resistors and are meant for 0402 shunting 0- Ω resistors that connect the IN+ and IN- pins of INA186 directly to S2x and S5x sockets. These resistors are useful when an input filter is implemented, and the voltages must be measured directly at the INA186 input pins.

4.5 D1x, D2x, D3x, D4x

These diodes are unpopulated, and are meant for the onboard implementation and experimentation of input protection circuitry when the input common-mode voltage exceeds the absolute maximum rating of the INA186 during a transient event. Using diodes in SOD-323 package for D4x and D2x ties the input traces to ground, and protects from overvoltage events. Using diodes in SOD-923 package for D3x and D1x connects the inputs to the supply plane, and protects from undervoltage events.

4.6 S0x, S1x, S2x, S3x, S4x, S5x, S6x, S7x, S8x, S9x, S10x, S11x, S12x

These pin sockets are not populated, and are for inserted wires and through-hole components, or to provide a test point. The pin sockets are used to test the INA186 with input/output filters, a through-hole shunt resistor, test points, or a combination of any three.

4.7 U1x - INA186

U1x is the location for the INA186Ax test device. Five device boards are supplied with the INA186EVM board. Each board is populated with one of the available device gains. This option allows users to test the devices and determine the gain setting that is best for a given application.

The following list of factors are involved in selecting the appropriate device:

- The INA186 devices are identical with the exception of the different gain settings.
- The differential input voltage is either applied across the inputs or developed based on the load current that flows through the shunt resistor.
- Make sure that the output voltage does not exceed the supply voltage. This limiting factor requires attention to device selection.
- The selected device must allow the output voltage to remain within the acceptable range after the developed input voltage is amplified by the respective device gain. The output voltage must remain within the device-specified swing limitations for response in the linear range.
- An output below the minimum allowable output requires the selection of a device with a higher gain. Likewise, an output above the maximum allowable output requires the selection of a device with a lower gain.

4.8 J0x, J1x

J0x and J1x are 0.240-inch, noninsulated, quick-fit terminals that are designed to insert into similarly-sized female receptacles. The kit provides two receptacles. Use insulated receptacles with J0x and J1x terminals to make sure that there is a strong and safe connection between the current source and EVM when dealing with high currents.

WARNING

If using the EVM to measure currents, make sure a proper power resistor is soldered at the R3x pads. Also make sure that the receptacles (connecting to J0x and J1x) and the respective crimped wires can support the amperage of the current being measured, and the necessary power dissipation. Do not exceed 15 A of current flowing between J0x and J1x. Failure to follow this requirement can result in hot surfaces (> 55°C), damage to the EVM, or personal injury.

Standard metal clips can electrically interface with these terminals when measuring lower currents.

The Rs+ (J0x) and Rs- (J1x) inputs accept a differential voltage that is amplified by the selected device gain, and is presented at the OUT test points (TP5x and S7x if populated). These inputs can also be used to connect the differential voltage developed across an external shunt in an existing circuit. The acceptable differential input voltage range is determined by the supply voltage and gain of the selected device.

5 Schematic, PCB Layout, and Bill of Materials

NOTE: Board layouts are not to scale. These figures are intended to show how the board is laid out; they are not intended to be used for manufacturing INA186EVM PCBs.

5.1 Schematics

Figure 1 through Figure 5 show the schematics for the INA186EVM PCB.

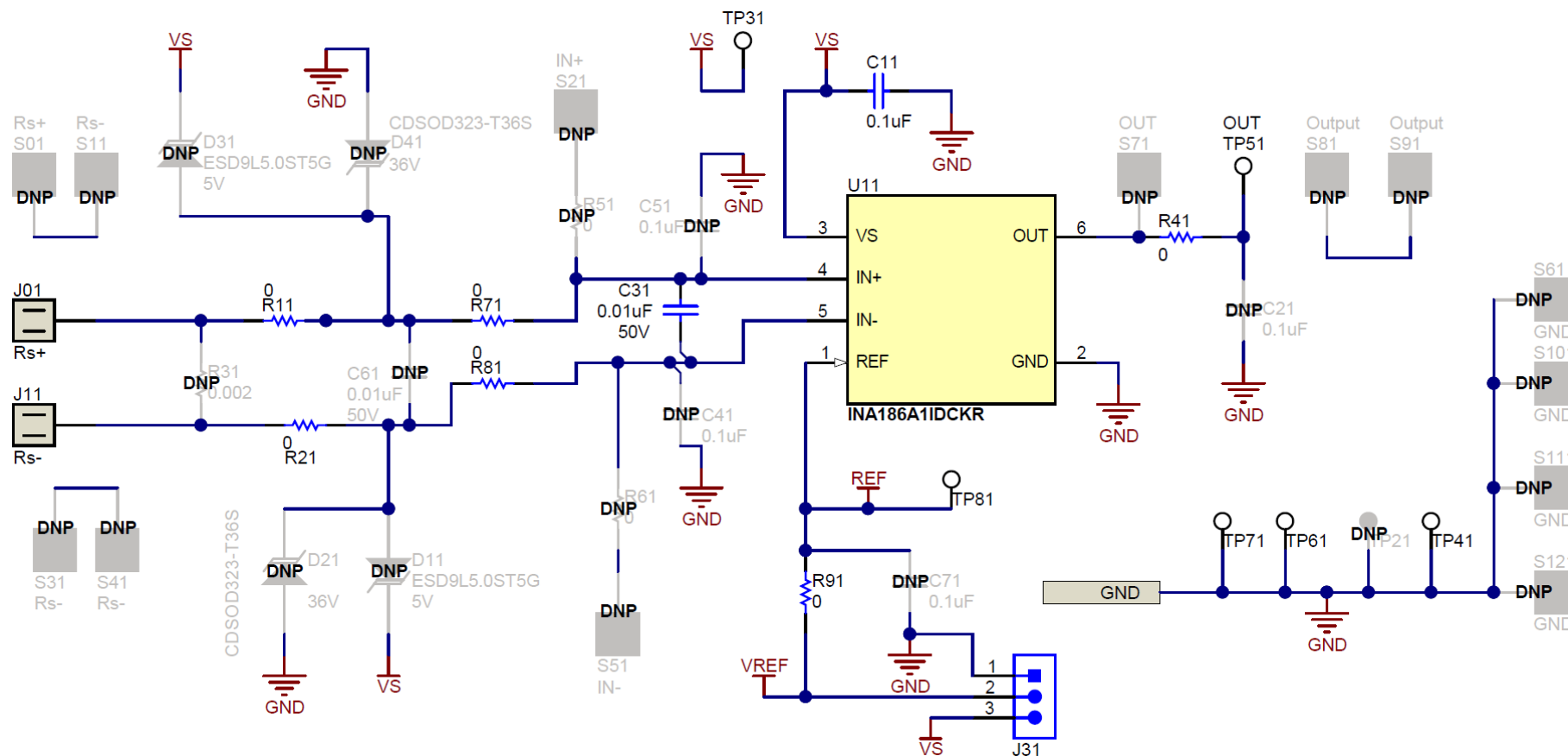

Figure 1. INA186EVM Schematic: Gain A1 Panel

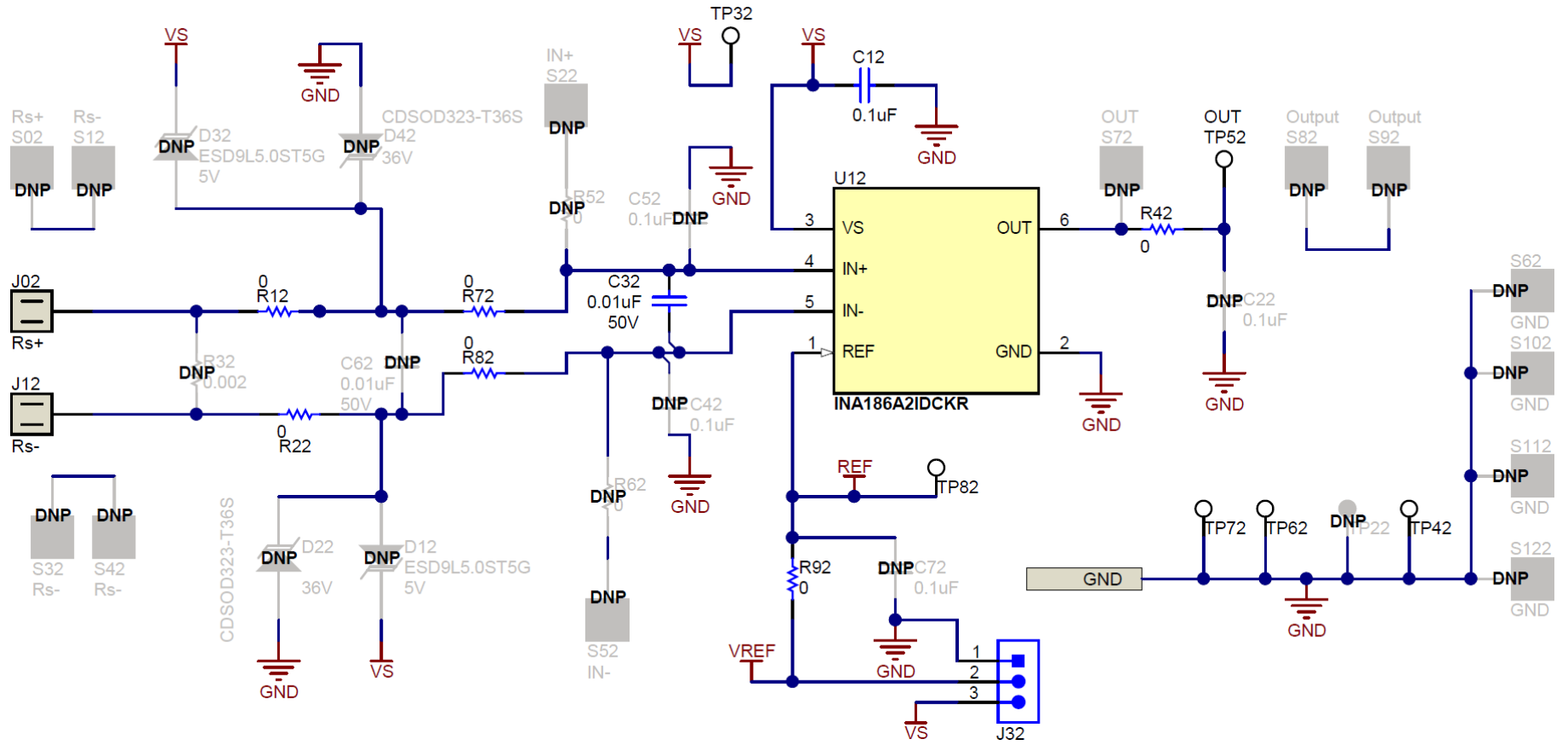

Figure 2. INA186EVM Schematic: Gain A2 Panel

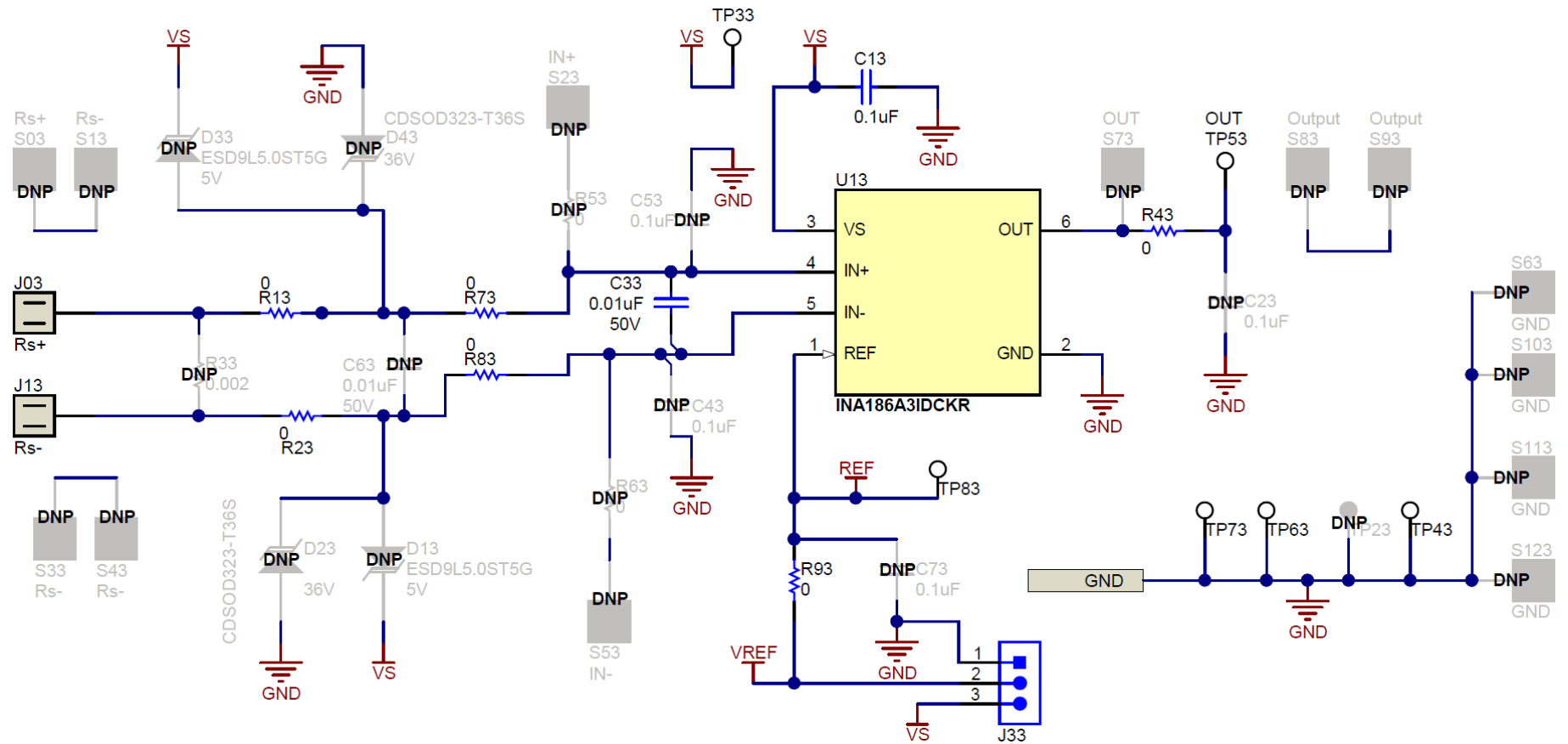

Figure 3. INA186EVM Schematic: Gain A3 Panel

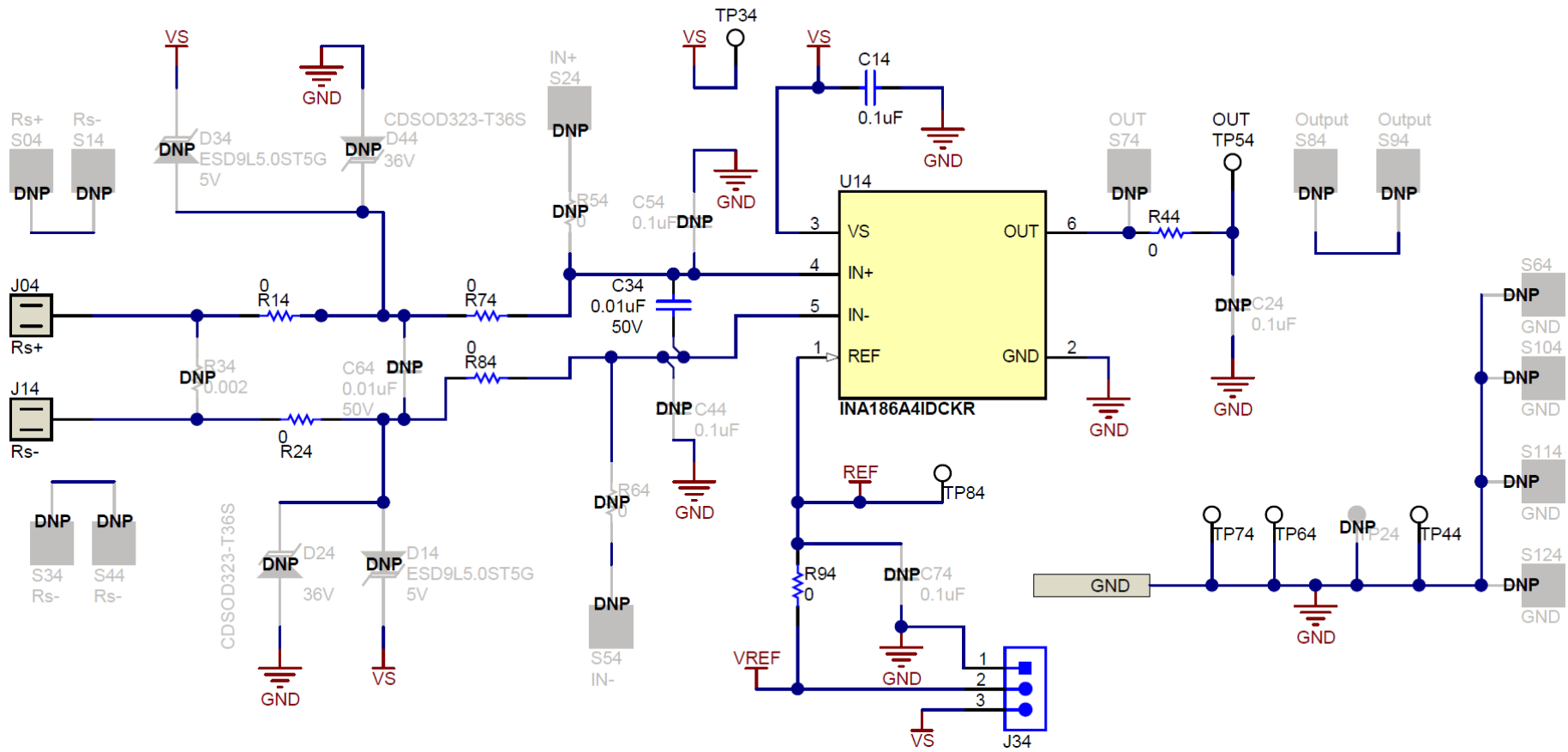

Figure 4. INA186EVM Schematic: Gain A4 Panel

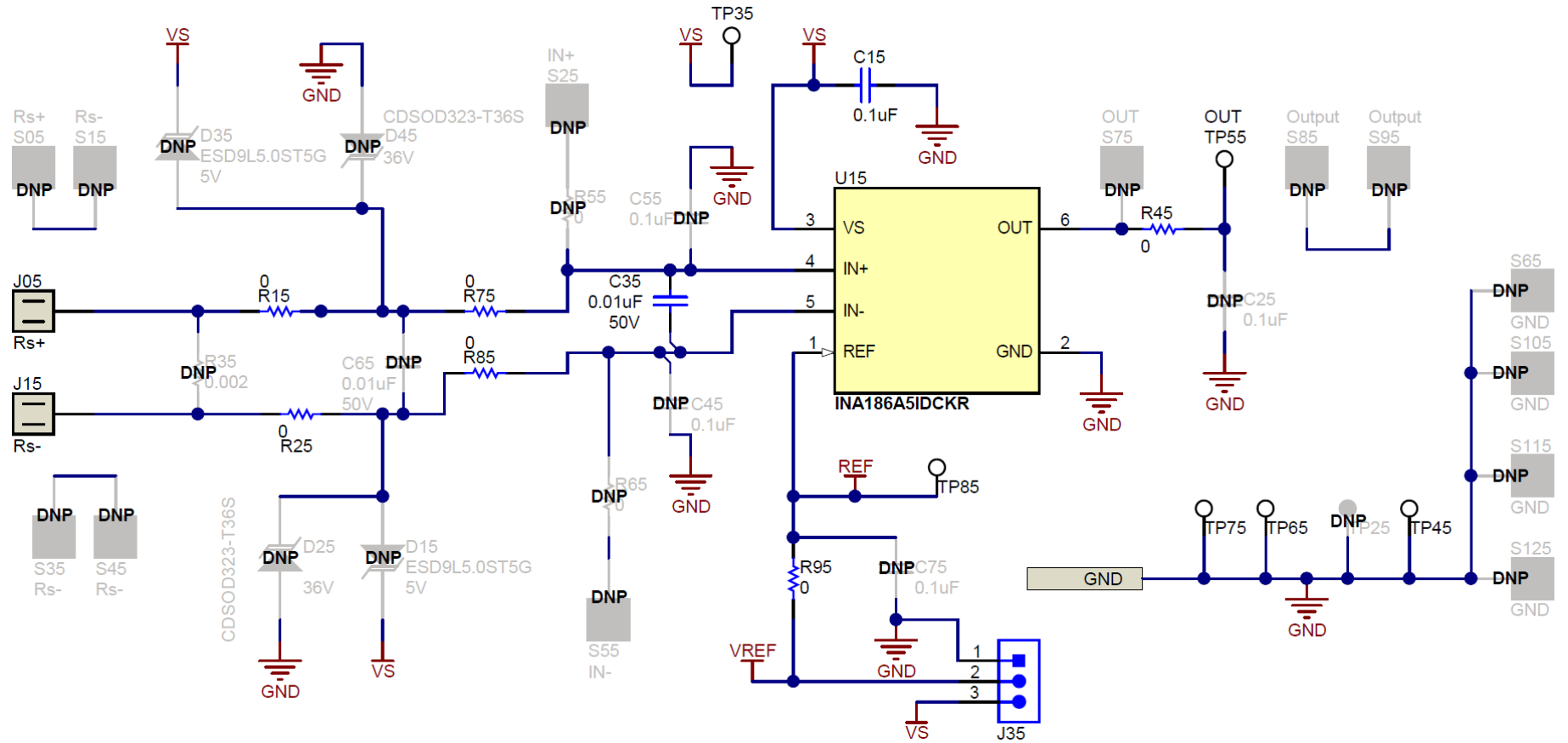

Figure 5. INA186EVM Schematic: Gain A5 Panel

5.2 PCB Layout

Figure 6 through Figure 12 illustrate the PCB layout for the INA186EVM.

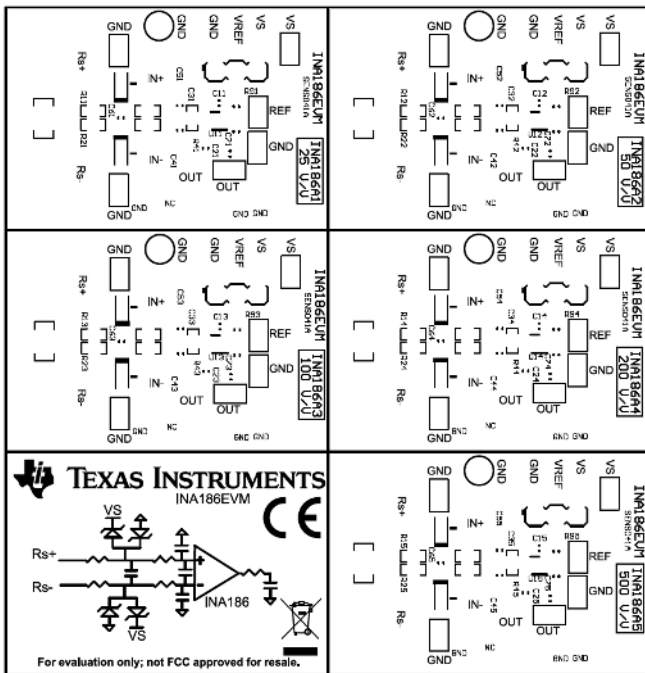

Figure 6. INA186EVM Top Overlay

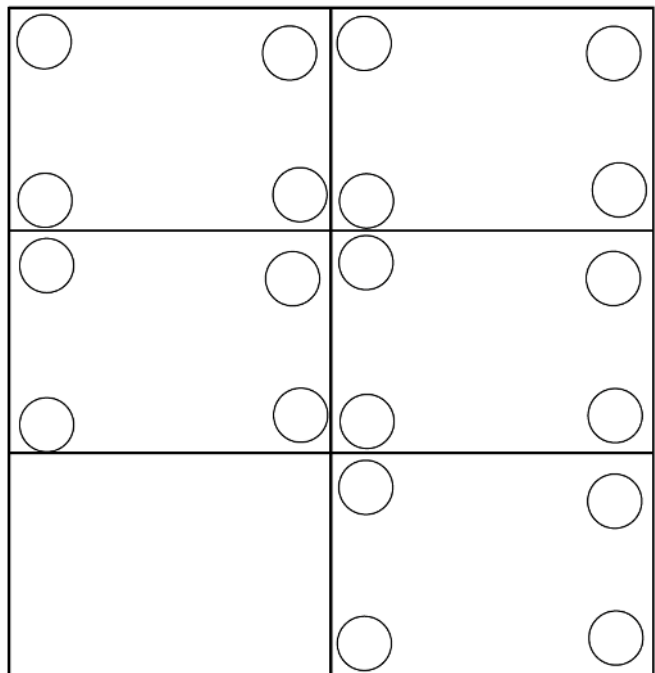

Figure 7. INA186EVM Bottom Overlay

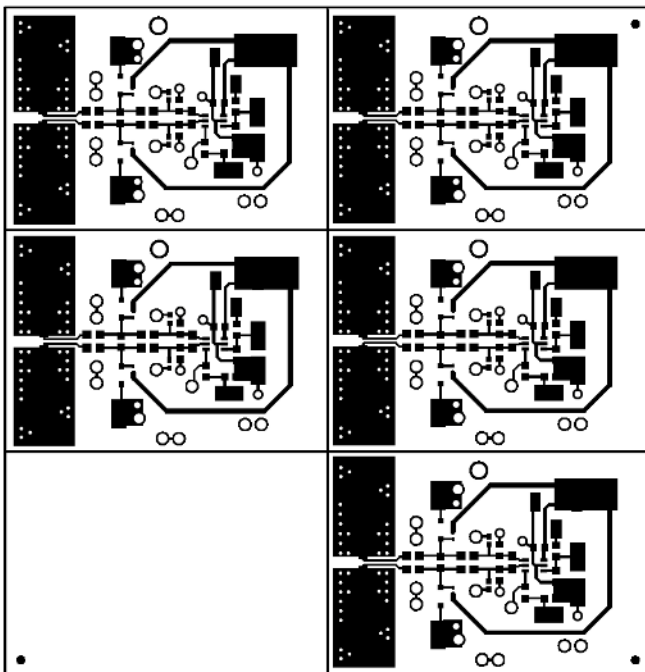

Figure 8. INA186EVM Top Layer

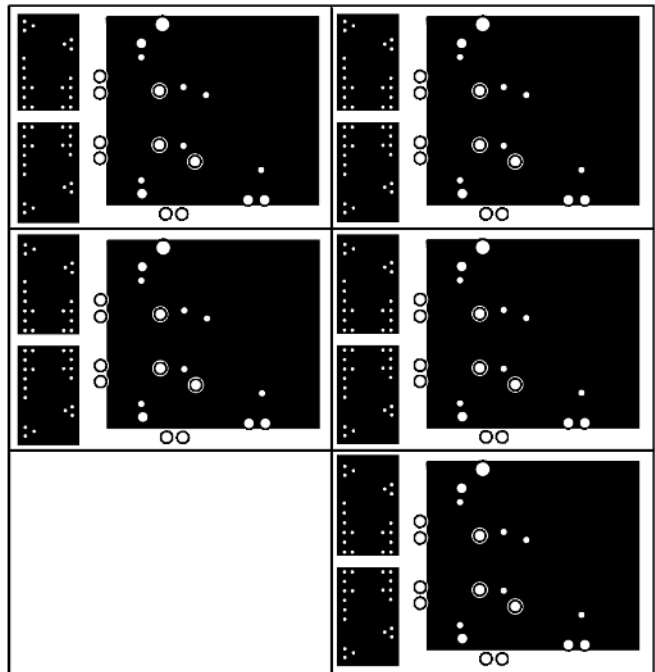

Figure 9. INA186EVM Bottom Layer

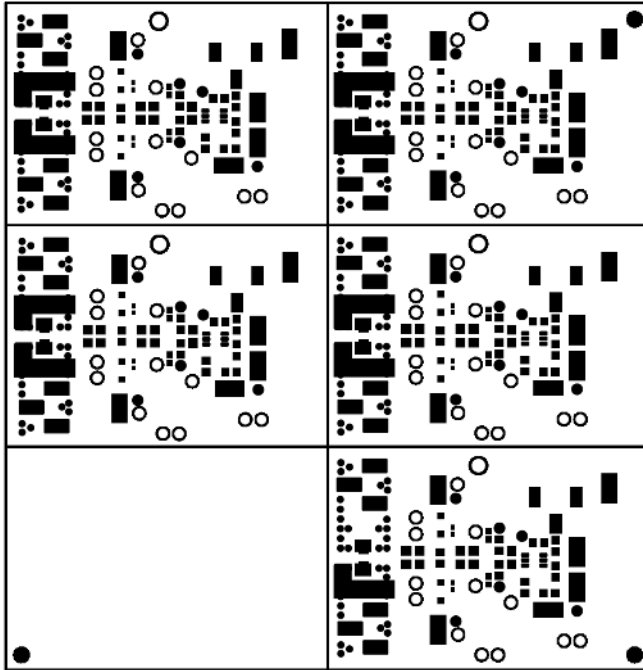

Figure 10. INA186EVM Top Solder

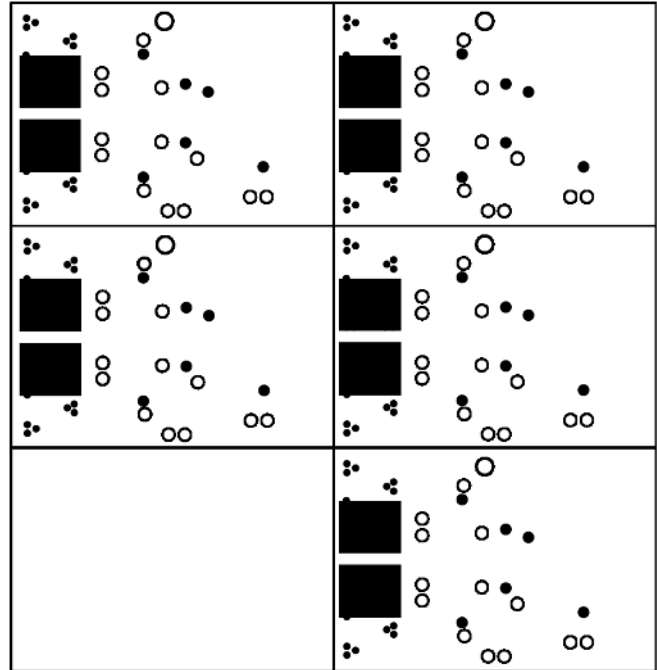

Figure 11. INA186EVM Bottom Solder

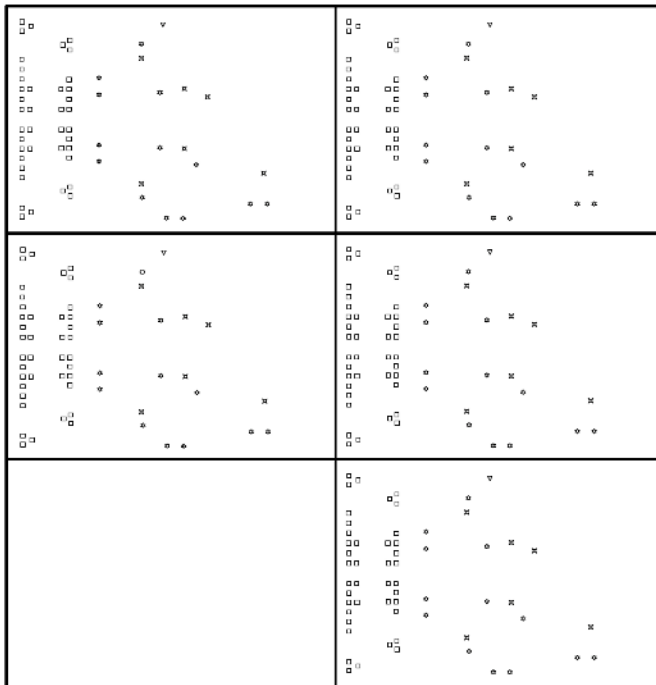

Figure 12. INA186EVM Drill Drawing

Symbol	Quantity	Finished Hole Size	Plated	Hole Type
□	200	15.00mil (0.381mm)	PTH	Round
✕	30	28.00mil (0.711mm)	PTH	Round
○	1	41.00mil (1.041mm)	PTH	Round
☆	64	44.00mil (1.118mm)	PTH	Round
▽	5	63.00mil (1.600mm)	PTH	Round
	300 Total			

5.3 Bill of Materials

Table 4 provides the parts list for the INA186EVM.

Table 4. Bill of Materials

Designator	QTY	Value	Description	Package Reference	Part Number	Manufacturer
B1, B2, B3, B4, B5, B6, B7, B8, B9, B10, B11, B12, B13, B14, B15, B16, B17, B18, B19, B20	20		Bumpon, Hemisphere, 0.25 X 0.075, Clear	75x250 mil	SJ5382	3M
C11, C12, C13, C14, C15	5	0.1 uF	CAP, CERM, 0.1 µF, 50 V, ±10%, X7R, 0603	0603	06035C104KAT2A	AVX
C31, C32, C33, C34, C35	5	0.01uF	CAP, CERM, 0.01 uF, 50 V, +/- 5%, C0G/NP0, 0603	0603	GRM1885C1H103JA01 D	MuRata
H1, H2, H3, H4, H5	5		CONN POST SHUNT NOVO 2POS (Kitting Item)	N/A	2-881545-2	TE Connectivity AMP Connectors
H6, H7	2		CONN QC RCPT 10-12AWG 0.250 (Kitting Item)	N/A	4-520448-2	TE Connectivity AMP Connectors
J01, J02, J03, J04, J05, J11, J12, J13, J14, J15	10		Quick-Fit 0.240 Tab	Keystone_4928TR	4928TR	Keystone
J31, J32, J33, J34, J35	5		Header, 2.54mm, 3x1, Gold, SMT	Harwin_M20-87703	M20-8770342	Harwin
R11, R12, R13, R14, R15, R21, R22, R23, R24, R25, R41, R42, R43, R44, R45, R71, R72, R73, R74, R75, R81, R82, R83, R84, R85 R91, R92, R93, R94, R95	30	0 Ω	RES, 0, 5%, 0.1 W, AEC-Q200 Grade 0, 0603	0603	ERJ-3GEY0R00V	Panasonic
TP31, TP32, TP33, TP34, TP35, TP41, TP42, TP43, TP44, TP45, TP51, TP52, TP53, TP54, TP55, TP61, TP62, TP63, TP64, TP65, TP71, TP72, TP73, TP74, TP75, TP81, TP82, TP83, TP84, TP85	30		Test Point, Miniature, SMT	Testpoint_Keystone_Miniature	5015	Keystone
U1	1	25 V/V	Low Supply, Voltage Output, Low- or High-Side Measurement, Bidirectional, Zero-Drift Series, Current- Shunt Monitor, DCK0006A (SOT-SC70-6)	DCK0006A	INA186A1DCKR	Texas Instruments
U2	1	50 V/V	Low Supply, Voltage Output, Low- or High-Side Measurement, Bidirectional, Zero-Drift Series, Current- Shunt Monitor, DCK0006A (SOT-SC70-6)	DCK0006A	INA186A2IDCKR	Texas Instruments
U3	1	100 V/V	Low Supply, Voltage Output, Low- or High-Side Measurement, Bidirectional, Zero-Drift Series, Current- Shunt Monitor, DCK0006A (SOT-SC70-6)	DCK0006A	INA186A3IDCKR	Texas Instruments
U4	1	200 V/V	Low Supply, Voltage Output, Low- or High-Side Measurement, Bidirectional, Zero-Drift Series, Current- Shunt Monitor, DCK0006A (SOT-SC70-6)	DCK0006A	INA186A4IDCKR	Texas Instruments
U5	1	500 V/V	Low Supply, Voltage Output, Low- or High-Side Measurement, Bidirectional, Zero-Drift Series, Current- Shunt Monitor, DCK0006A (SOT-SC70-6)	DCK0006A	INA186A5IDCKR	Texas Instruments
C21, C22, C23, C24, C25, C41, C42, C43, C44, C45, C51, C52, C53, C54, C55, C71, C72, C73, C74, C75	0	0.1 uF	CAP, CERM, 0.1 µF, 50 V, ±10%, X7R, 0603	0603	06035C104KAT2A	AVX
C61, C62, C63, C64, C65	0	0.01uF	CAP, CERM, 0.01 uF, 50 V, +/- 5%, C0G/NP0, 0603	0603	GRM1885C1H103JA01 D	MuRata

Table 4. Bill of Materials (continued)

Designator	QTY	Value	Description	Package Reference	Part Number	Manufacturer
D11, D12, D13, D14, D15, D31, D32, D33, D34, D35	0	5V	Diode, TVS, Uni, 5 V, 9.8 Vc, AEC-Q101, SOD-923	SOD-923	ESD9L5.0ST5G	ON Semiconductor
D21, D22, D23, D24, D25, D41, D42, D43, D44, D45	0	36V	Diode, TVS, Uni, 36 V, 75 Vc, SOD-323	SOD-323	CDSOD323-T36S	Bourns
R31, R32, R33, R34, R35	0	0.002 Ω	RES, 0.002, 1%, 1 W, 1206	1206	CSNL1206FT2L00	Stackpole Electronics Inc
R51, R52, R53, R54, R55, R61, R62, R63, R64, R65	0	0 Ω	RES, 0, 5%, 0.063 W, 0402	0402	MCR01MZPJ000	Rohm
S01, S02, S03, S04, S05, S11, S12, S13, S14, S15, S21, S22, S23, S24, S25, S31, S32, S33, S34, S35, S41, S42, S43, S44, S45, S51, S52, S53, S54, S55, S61, S62, S63, S64, S65, S71, S72, S73, S74, S75, S81, S82, S83, S84, S85, S91, S92, S93, S94, S95, S101, S102, S103, S104, S105, S111, S112, S113, S114, S115, S121, S122, S123, S124, S125	0		Socket, 1 Pos, TH	Pin receptacle	147444-1	TE Connectivity
TP21, TP22, TP23, TP24, TP25	0		Test Point, Compact, White, TH	Keystone5007	5007	Keystone

IMPORTANT NOTICE AND DISCLAIMER

TI PROVIDES TECHNICAL AND RELIABILITY DATA (INCLUDING DATA SHEETS), DESIGN RESOURCES (INCLUDING REFERENCE DESIGNS), APPLICATION OR OTHER DESIGN ADVICE, WEB TOOLS, SAFETY INFORMATION, AND OTHER RESOURCES "AS IS" AND WITH ALL FAULTS, AND DISCLAIMS ALL WARRANTIES, EXPRESS AND IMPLIED, INCLUDING WITHOUT LIMITATION ANY IMPLIED WARRANTIES OF MERCHANTABILITY, FITNESS FOR A PARTICULAR PURPOSE OR NON-INFRINGEMENT OF THIRD PARTY INTELLECTUAL PROPERTY RIGHTS.

These resources are intended for skilled developers designing with TI products. You are solely responsible for (1) selecting the appropriate TI products for your application, (2) designing, validating and testing your application, and (3) ensuring your application meets applicable standards, and any other safety, security, regulatory or other requirements.

These resources are subject to change without notice. TI grants you permission to use these resources only for development of an application that uses the TI products described in the resource. Other reproduction and display of these resources is prohibited. No license is granted to any other TI intellectual property right or to any third party intellectual property right. TI disclaims responsibility for, and you will fully indemnify TI and its representatives against, any claims, damages, costs, losses, and liabilities arising out of your use of these resources.

TI's products are provided subject to [TI's Terms of Sale](#) or other applicable terms available either on ti.com or provided in conjunction with such TI products. TI's provision of these resources does not expand or otherwise alter TI's applicable warranties or warranty disclaimers for TI products.

TI objects to and rejects any additional or different terms you may have proposed.

Mailing Address: Texas Instruments, Post Office Box 655303, Dallas, Texas 75265
Copyright © 2022, Texas Instruments Incorporated