

PRODUCT DATA DRAWING

REVISION HISTORY			
REV	DESCRIPTION	DATE	APPROVED
-	DCN 34595	10/06	STW
A	DCN 36894	07/09	JMC

MATERIAL:

BODY & COUPLING NUT: STAINLESS STEEL PER AMS-5640, ALLOY UNS S30300, TYPE 1

CONTACTS & RETAINING CLIP: BERYLLIUM COPPER PER ASTM B196, ALLOY UNS C17300, TD04

SPRING: STAINLESS STEEL PER ASTM A313, TYPE 331 ALLOY UNS S17700

INSULATOR: PTFE PER ASTM D1710, TYPE I, GRADE 1, CLASS B

GASKET: SILICONE RUBBER PER A-A-59588, CLASS 2B, GRADE 50/60

FINISH:

BODY & CONTACTS: GOLD PER ASTM B488, TYPE II, CODE C, CLASS 1.27; OVER NICKEL PER AMS-QQ-N-290, CLASS 1, .00005" MIN.

COUPLING NUT: PASSIVATED PER AMS-2700, TYPE 2

PERFORMANCE:

IMPEDANCE: 50 OHMS
FREQ. RANGE: DC TO 18.0 GHz
DWV: 1000 VRMS
OPERATING TEMP.: -55°C TO +125°C
INSUL. RES.: 5000 MEGOHMS, MIN.

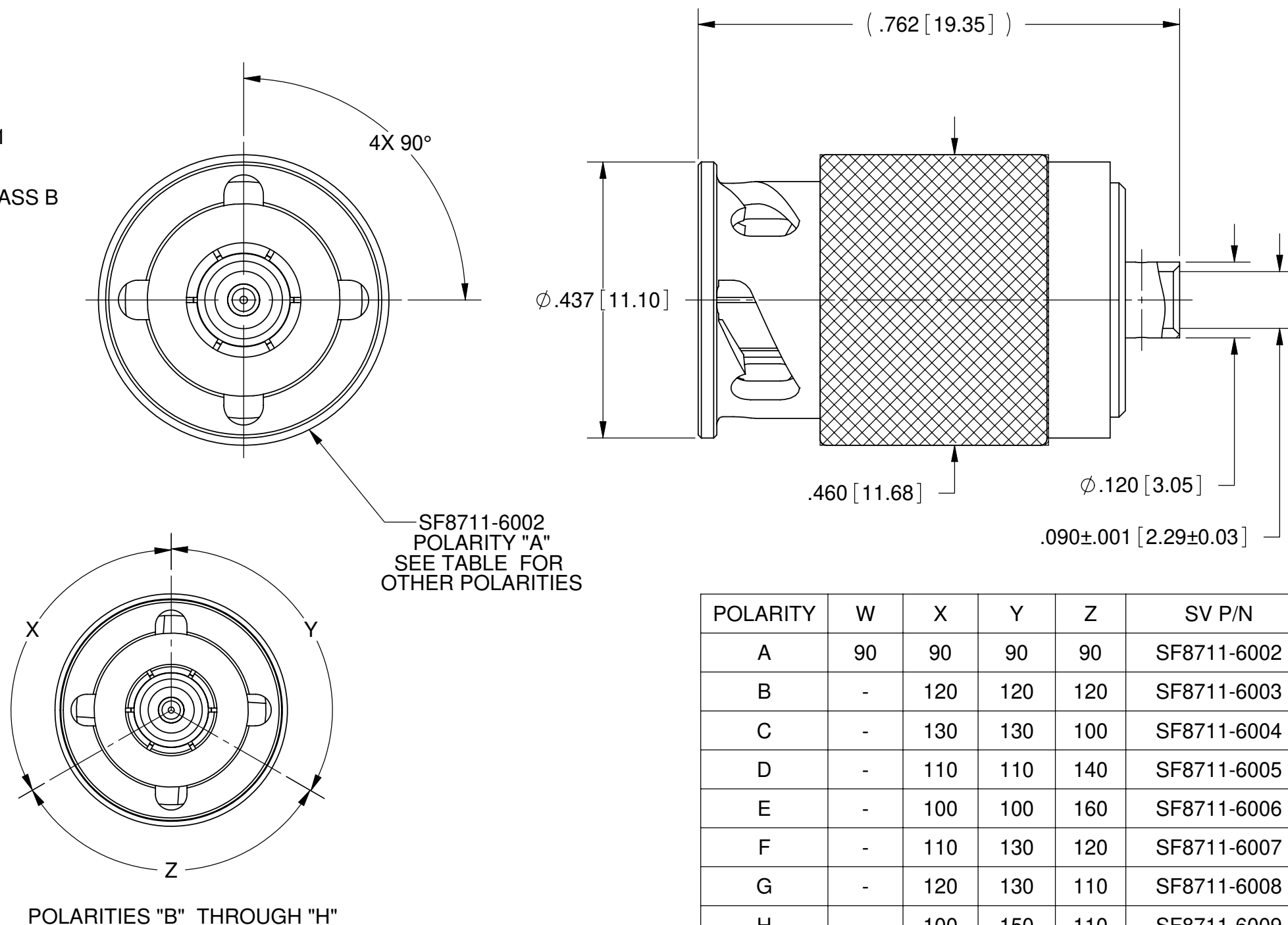

MATERIAL:	SEE NOTES
FINISH:	SEE NOTES
SURFACE AREA:	N/A
PROPRIETARY	
THE INFORMATION CONTAINED IN THIS DRAWING IS THE SOLE PROPERTY OF SV MICROWAVE, INC. ANY REPRODUCTION IN PART OR AS A WHOLE WITHOUT THE WRITTEN PERMISSION OF SV MICROWAVE, INC IS PROHIBITED.	

DIMENSIONS ARE IN INCHES TOLERANCES:	
FRACTIONAL:	±1/64 ANGULAR: X° ±1'0" X"X' ±15'
DECIMAL:	.X ±.030 .XX ±.010 .XXX ±.005
INTERPRET DIMENSIONS AND TOLERANCES PER ASME Y14.5M - 1994	
THIRD ANGLE PROJECTION	

UNLESS OTHERWISE SPECIFIED	
1) ALL DIMENSIONS ARE IN INCHES (MILLIMETERS) 2) ALL DIMENSIONS ARE AFTER PLATING. 3) BREAK CORNERS & EDGES .005 R. MAX. 4) CHAM. 1ST & LAST THREADS. 5) SURFACE ROUGHNESS 63-MIL-STD-10. 6) DIA. 'S ON COMMON CENTERS TO BE CONCENTRIC WITHIN .005 T.I.R. 7) REMOVE ALL BURRS	
DRAWN:	PDW 10/03/06
CHECKED:	STW 10/03/06
APPROVED:	STW 10/06/06

SV Microwave, Inc.	
2400 Centrepark West Drive, Suite 100 West Palm Beach, FL 33409	
TITLE: ZMA PLUG FOR TFLEX-405 CABLE	
SIZE	CAGE CODE DWG. NO.
B	95077 SF8711-6002 TO 6009
SCALE: 5:1	SHEET 1 OF 1