

This drawing involves proprietary design rights of Tyco Electronics Corporation, and all design, manufacture, reproduction, use and sale rights regarding the same are expressly reserved. It is submitted for a specific purpose and the recipient by accepting this drawing, assumes custody and control and agrees to take reasonable precautions; (a) that this drawing will not be copied and reproduced, in whole or in part, or its contents revealed in any manner, or to any person except to meet the purpose for which it was delivered and (b) that any special features peculiar to this design will not be incorporated in other projects without the expressed written permission of Tyco Electronics Corporation.

REVISIONS			
EC	REV	DESCRIPTION	DATE
CPR	A	NEW RELEASE	11/08/05

6. THIS CONNECTOR MATE WITH PIN CONNECTOR 6643106-1.
5. ITEMS PROVIDED TO THIS SPECIFICATION TO BE PERMANENTLY IDENTIFIED PER THE FOLLOWING IDENTIFIER:

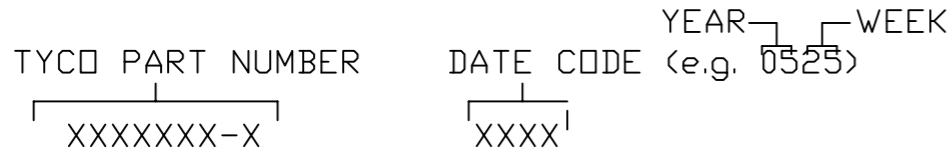

4 SOCKET CRIMP CONTACTS AND SHOULDER SCREWS SHALL BE PACKAGED AND PLACED IN THE BOX WITH THE CONNECTOR ASSEMBLY. THIS CONNECTOR ASSEMBLY SHALL BE PACKAGED AS A KIT.

3. FINISHES:

CONTACTS: SILVER PLATED PER ASTM B 700
OVER NICKEL PER QQ-N-290.

2. MATERIALS:

HOUSINGS: THERMOPLASTIC, GLASS REINFORCED, COLOR-BLACK
UL94V-0 FLAMMABILITY RATED.

SOCKET CONTACTS: LEAD COPPER.



CROWN BANDS: BERYLLIUM COPPER.

RETENTION CLIPS: BERYLLIUM COPPER OR STAINLESS STEEL.

1. PART NUMBER CHANGES AND OR DESIGN CHANGES AFFECTING ITEM INTERCHANGEABILITY REQUIRE PRIOR ELCON APPROVAL AND AUTHORIZATION BY REVISION TO THIS DRAWING.

NOTES: UNLESS OTHERWISE SPECIFIED

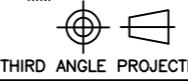
TABLE FOR SOCKET CONNECTOR PN 6643107-1			
PART NUMBER	DESCRIPTION	POSITION	QTY
1648128-2	CONNECTOR, SOCKET	N/A	1
6648318-1	CONTACT, SOCKET, SIZE #12, CRIMP	1 - 8	8
1650575-1	SHOULDER SCREW, #8-32	N/A	2

 <small>THIRD ANGLE PROJECTION</small>	<small>UNLESS OTHERWISE SPECIFIED DIMENSIONS ARE IN INCHES (METRIC)</small> <small>TOLERANCES</small> ANGLES ± .5° <small>DECIMALS</small> .XXX ± .010 (.25) .XX ± .02 (.3)	<small>INCH OR INCH (MM)</small> <small>MM</small>	DRAWN HA NGUYEN CHECKED APPROVED APPROVED D. CHAU DCA APPROVED M. ALIM ACAD FILE NUMBER C6643107A.DWG	DATE 11/08/05 11/08/05 11/08/05	 Tyco Electronics Corporation Menlo Park, Ca 94025  TITLE CONNECTOR, SOCKET HV8P DRAWER PN 6643107-1 SIZE DWG NUMBER B C= 6643107 REV. A
				DWG SCALE 1=1	SH 1 OF 3

This drawing involves proprietary design rights of Tyco Electronics Corporation, and all design, manufacture, reproduction, use and sale rights regarding the same are expressly reserved. It is submitted for a specific purpose and the recipient by accepting this drawing, assumes custody and control and agrees to take reasonable precautions; (a) that this drawing will not be copied and reproduced, in whole or in part, or its contents revealed in any manner, or to any person except to meet the purpose for which it was delivered and (b) that any special features peculiar to this design will not be incorporated in other projects without the expressed written permission of Tyco Electronics Corporation.

REVISIONS			
EC	REV	DESCRIPTION	DATE
		SEE SHEET 1	

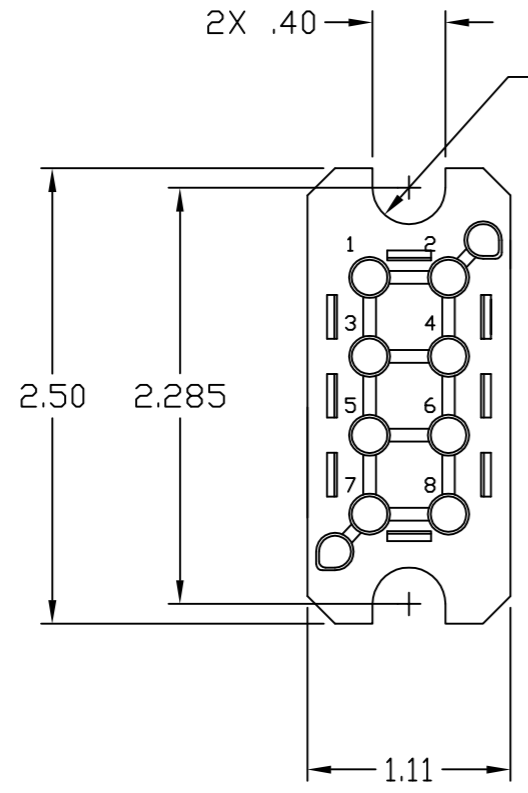

FRONT VIEW

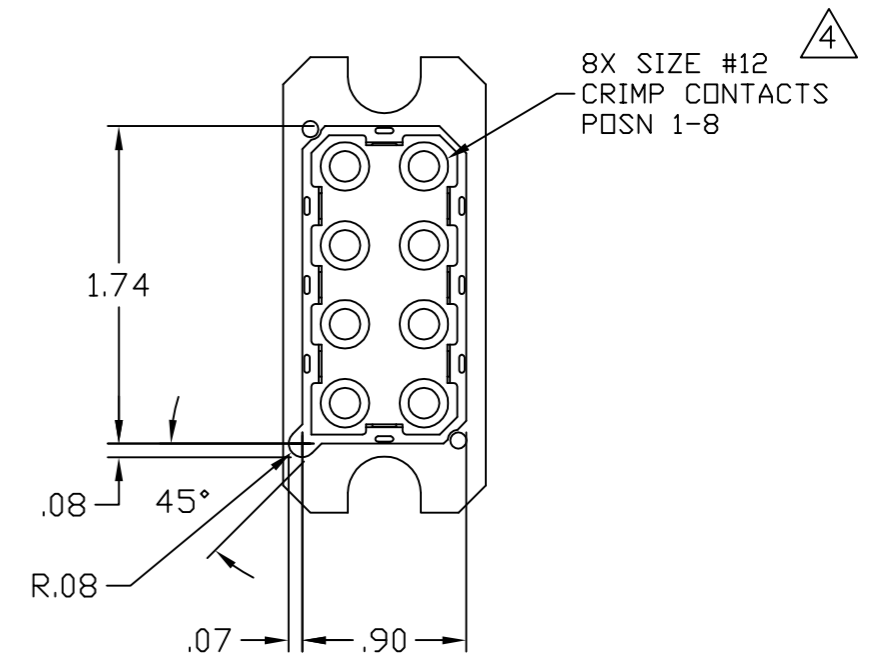
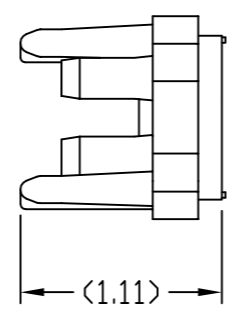
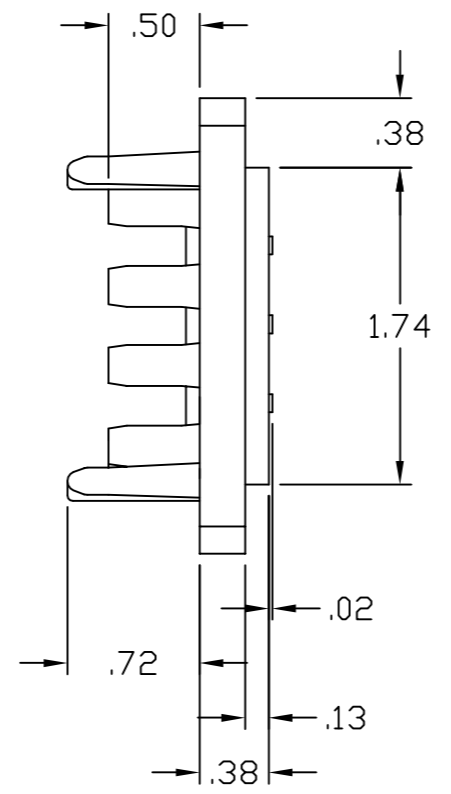

REAR VIEW

INCH OR INCH (MM) THIRD ANGLE PROJECTION UNLESS OTHERWISE SPECIFIED DIMENSIONS ARE IN INCHES (METRIC) TOLERANCES ANGLES ± .5° DECIMALS .XXX ± .010 (.25) .XX ± .02 (.3)	DRAWN HA NGUYEN	DATE 11/08/05	 Tyco Electronics Corporation Menlo Park, Ca 94025 		
	CHECKED			TITLE CONNECTOR, SOCKET HV8P DRAWER PN 6643107-1	
	APPROVED D. CHAU	11/08/05	SIZE B		DWG NUMBER C= 6643107
	APPROVED M. ALIM	11/08/05	ACAD FILE NUMBER C6643107A.DWG		DWG SCALE 1=1

This drawing involves proprietary design rights of Tyco Electronics Corporation, and all design, manufacture, reproduction, use and sale rights regarding the same are expressly reserved. It is submitted for a specific purpose and the recipient by accepting this drawing, assumes custody and control and agrees to take reasonable precautions; (a) that this drawing will not be copied and reproduced, in whole or in part, or its contents revealed in any manner, or to any person except to meet the purpose for which it was delivered and (b) that any special features peculiar to this design will not be incorporated in other projects without the expressed written permission of Tyco Electronics Corporation.

REVISIONS			
EC	REV	DESCRIPTION	DATE
		SEE SHEET 1	

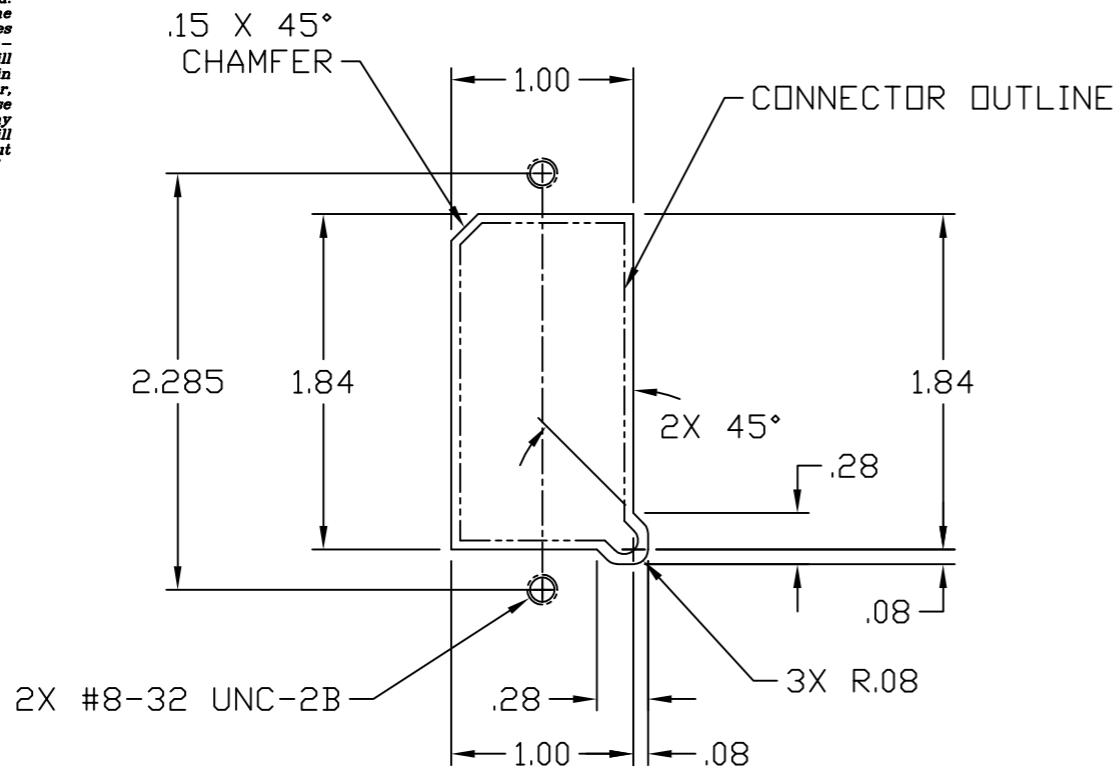

SUGGESTED PANEL CUTOUT
VIEWED FROM CONNECTOR MOUNTING SIDE

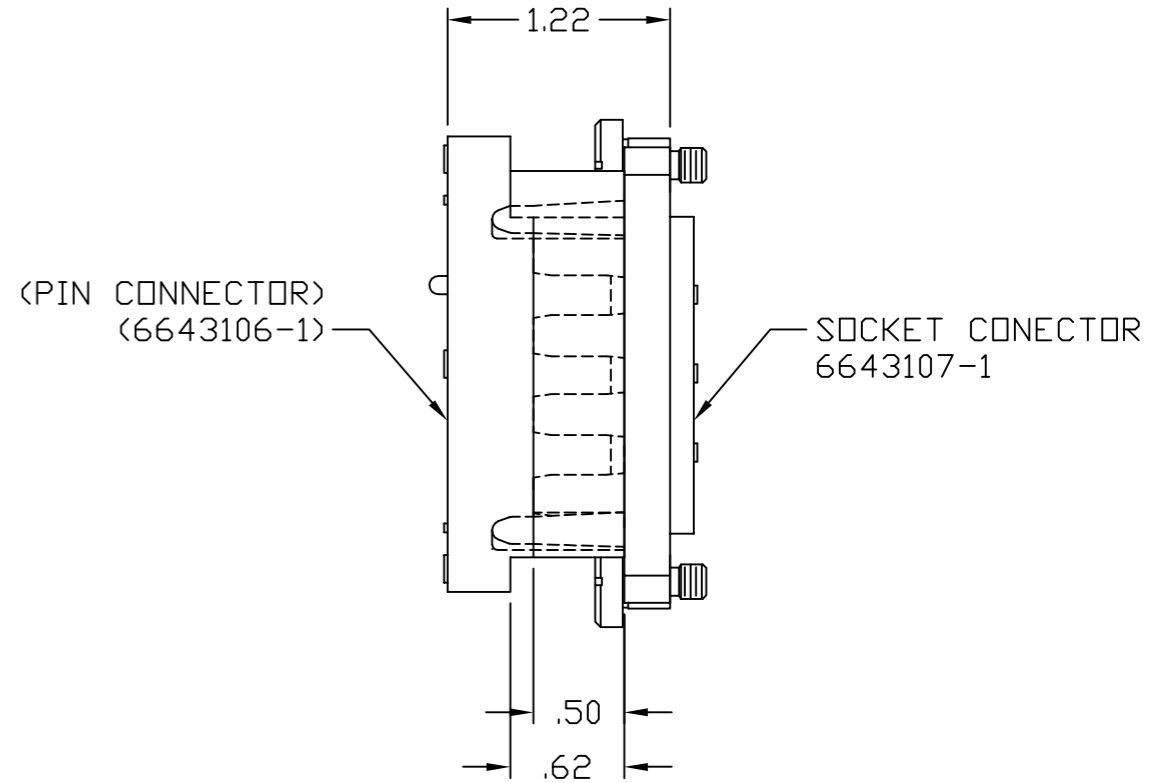

MATED CONDITION

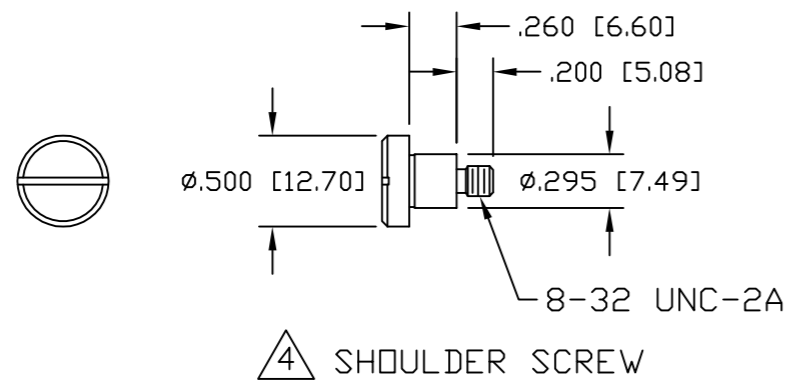

INCH OR INCH (MM) THIRD ANGLE PROJECTION UNLESS OTHERWISE SPECIFIED DIMENSIONS ARE IN INCHES (METRIC) TOLERANCES ANGLES $\pm .5^\circ$ DECIMALS .XXX $\pm .010 (.25)$.XX $\pm .02 (.3)$	DRAWN HA NGUYEN CHECKED	DATE 11/08/05	tyco Tyco Electronics Corporation Electronics Menlo Park, Ca 94025 ELCON
	APPROVED APPROVED D. CHAU DCA APPROVED M. ALIM ACAD FILE NUMBER C6643107A.DWG	APPROVED 11/08/05 11/08/05	TITLE USER INFORMATION RECOMMENDED PANEL CUTOUT AND MATED CONDITION SIZE B DWG NUMBER C-6643107 REV. A