

RECOMMENDED PTH PATTERN

VIEW SCALE 1:1

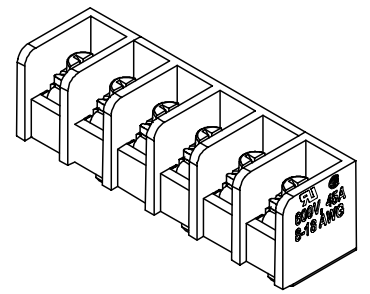
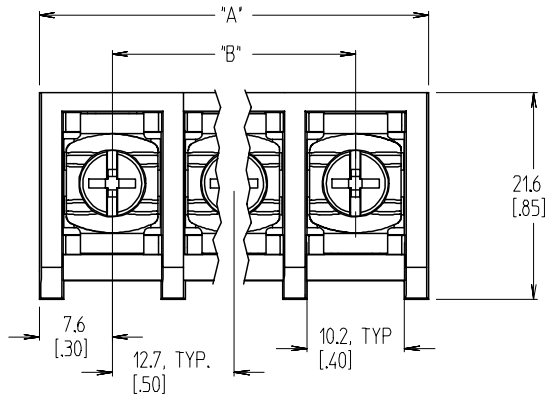

6 CIRCUIT SHOWN ACTUAL SIZE

MATERIAL NUMBER, OPT GOLD (-04)	MATERIAL NUMBER (STD PART)	OLD CATALOG NUMBER REFERENCE	NUMBER OF CIRCUITS "XX"	A	B
	38660-7802	38669-0001	2	27.9 [1.10]	12.70 [1.500]
38669-0004	38660-7803	38669-0003	3	40.6 [1.60]	25.40 [1.000]
38669-0006	38660-7804	38669-0005	4	53.3 [2.10]	38.10 [1.500]
	38660-7805	38669-0007	5	66.0 [2.60]	50.80 [2.000]
	38660-7806	38669-0008	6	78.7 [3.10]	63.50 [2.500]
	38660-7807		7	91.4 [3.60]	76.20 [3.000]
	38660-7808		8	104.1 [4.10]	88.90 [3.500]
	38660-7809	38669-0009	9	116.8 [4.60]	101.60 [4.000]
	38660-7810		10	129.5 [5.10]	114.30 [4.500]
	38660-7811		11	142.2 [5.60]	127.00 [5.000]
	38660-7812		12	154.9 [6.10]	139.70 [5.500]
	38660-7813		13	167.6 [6.60]	152.40 [6.000]
	38660-7814		14	180.3 [7.10]	165.10 [6.500]
	38660-7815		15	193.0 [7.60]	177.80 [7.000]

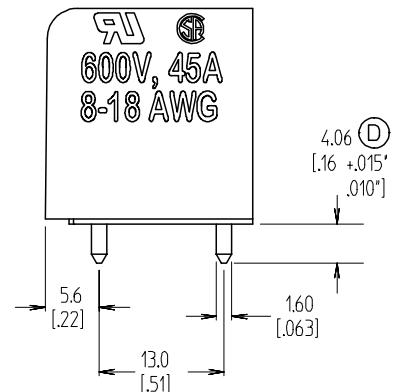
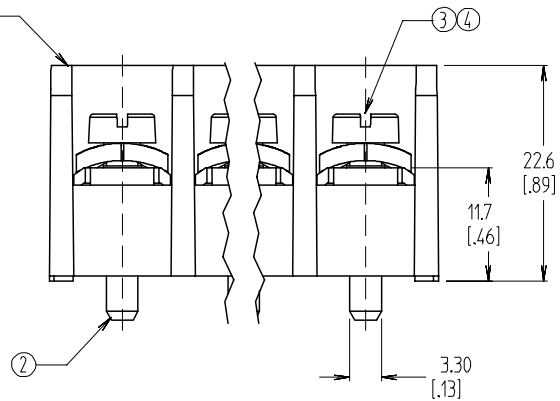
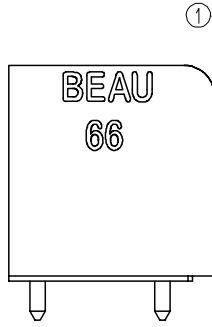

NOTES:

1. MATERIAL: SEE TABLE
2. FINISHES: SEE TABLE
3. PRODUCT SPECIFICATION: NOT REQUIRED
4. PACKAGING: NOT REQUIRED
5. MATES WITH: NONE
6. "XX" - REFERS TO THE NUMBER OF CIRCUIT POSITIONS
7. INCH DIMENSIONS ARE SHOWN IN BRACKETS [XXX].
8. ALL COMPONENTS ARE ROHS COMPLIANT.

ITEM	QTY	DESCRIPTION	MATERIAL	FINISH
4	XX	SCREW	STEEL	ZN/YELLOW CHROMATE
3	XX	SCREW	STEEL	GOLD
2	XX	TERMINAL	RED BRASS	TIN OVER COPPER
1	1	INSULATOR	THERMOPLASTIC	BLACK

UPDATE TAIL TOL. EC NO: ETC2007-0428 DRWN: JENCINAS 2007/06/04 CHKD: JENCINAS 2007/06/10 APPR: JMACNEIL 2007/06/11	QUALITY SYMBOLS ▽=0 ▽=0	GENERAL TOLERANCES (UNLESS SPECIFIED) <table border="1"> <thead> <tr> <th></th> <th>mm</th> <th>INCH</th> </tr> </thead> <tbody> <tr><td>4 PLACES</td><td>± ---</td><td>± ---</td></tr> <tr><td>3 PLACES</td><td>± ---</td><td>± .005</td></tr> <tr><td>2 PLACES</td><td>± 0.13</td><td>± .01</td></tr> <tr><td>1 PLACE</td><td>± 0.3</td><td>± ---</td></tr> </tbody> </table> ANGULAR ± 2 °		mm	INCH	4 PLACES	± ---	± ---	3 PLACES	± ---	± .005	2 PLACES	± 0.13	± .01	1 PLACE	± 0.3	± ---	DIMENSION STYLE MM/IN	SCALE 2:1	DESIGN UNITS INCH	THIRD ANGLE PROJECTION
		mm	INCH																		
	4 PLACES	± ---	± ---																		
	3 PLACES	± ---	± .005																		
2 PLACES	± 0.13	± .01																			
1 PLACE	± 0.3	± ---																			
DRAWN BY R. KEMP DATE 2002/08/14	CHECKED BY R. STONE DATE 2002/08/15	APPROVED BY L. ROTHAUSS DATE 2002/08/16	TITLE SR BTS, 12.70 [1.500] PITCH, PC, NO MTG ASSY	MOLEX INCORPORATED																	
MATERIAL NO. SEE CHART			DOCUMENT NO. SD-38669-001	SHEET NO. 1 OF 1																	
DRAFT WHERE APPLICABLE MUST REMAIN WITHIN DIMENSIONS																					