

**STRAIGHT PLUG CRIMP TYPE  
CABLE 5/50 D**

**R143.073.000**  
**SERIES TNC**

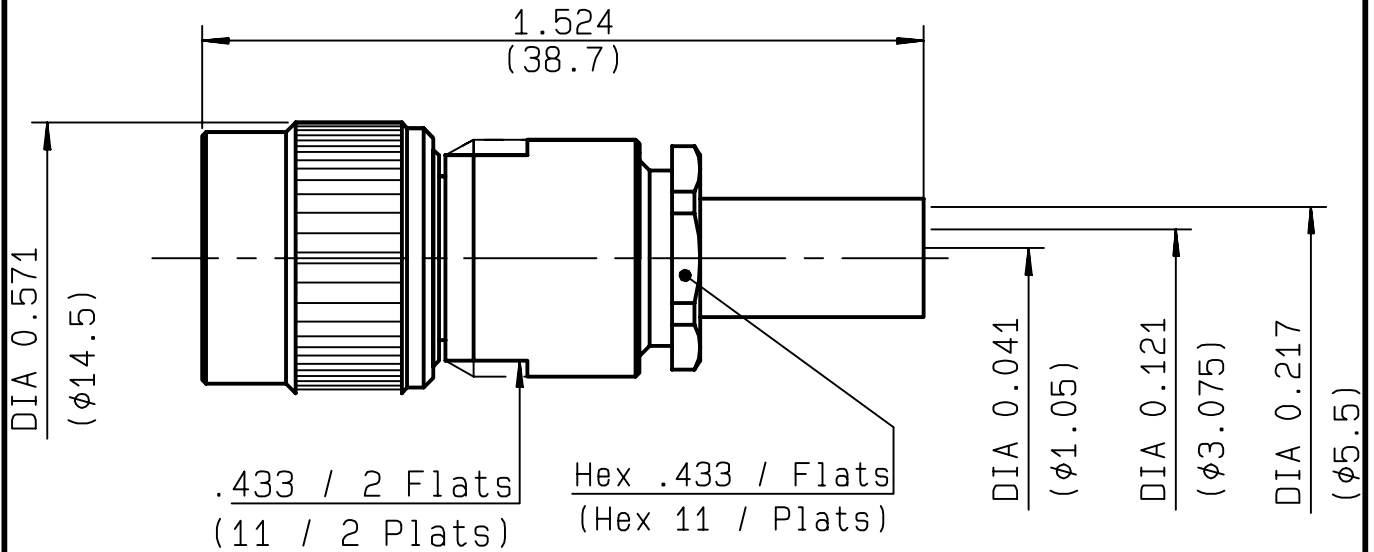

NOMINAL IMPEDANCE	<b>50</b> Ω
FREQUENCY RANGE	<b>0-4</b> GHz
TEMPERATURE RATING	<b>-65/+165</b> °C
V.S.W.R	<b>1.30</b> + <b>0</b> x F(GHz)Maxi
RF INSERTION LOSS	<b>0.06</b> √F(GHz) dB Maxi
VOLTAGE RATING	<b>500</b> Veff Maxi
DIELECTRIC WITHSTANDING VOLTAGE	<b>1500</b> Veff Mini
INSULATION RESISTANCE	<b>5000</b> MΩMini
HERMETIC SEAL	<b>NA</b> Atm.cm <sup>3</sup> /s
LEAKAGE (pressurized only)	<b>NA</b>
MECHANICAL DURABILITY	<b>500</b> Cycles
WEIGHT	<b>19.79</b> gr
SPECIFICATION	

CABLES : <b>KX 23</b>
<b>RG 142</b>
<b>RG 142 FTX</b>
<b>RG 223</b>
<b>RG 400</b>
OTHERS CHARACTERISTICS
CABLE RETENTION <b>180</b> N Mini
CENTER CONTACT RETENTION
Axial force - mating end <b>27</b> N Mini
Axial force - opposite end <b>27</b> N Mini
Torque <b>NA</b> cm.N Mini
RECOMMENDED TORQUES
Mating <b>NA</b> cm.N
Panel nut <b>NA</b> cm.N
Clamp nut <b>450</b> cm.N

CONNECTOR PARTS	MATERIALS	FINISH	(all values are given in micrometers)
BODY	BRASS	NICKEL 2	
OUTER CONTACT			
CENTER CONTACT	BRASS	GOLD 0.5 OVER NICKEL 2	
INSULATOR	PTFE	-	
GASKET	SILICONE RUBBER	-	
OTHERS PIECES	BRASS	NICKEL 2	

ISSUE	CREATION DATE	FILE PART-NUMBER
<b>0245C02</b>	<b>04/12/1990</b>	



LELEU

The information given here is subject to change without notice. Design changes may be in order to improve the product.

*Connect to the future*



**R143.073.000**

ISSUE **0245C02** SERIES **TNC**

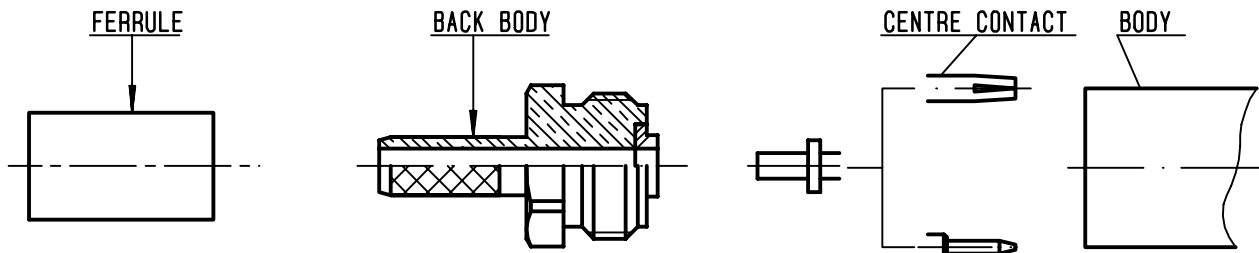

①

Slide onto the cable the ferrule .  
Strip the cable .  
-  
-

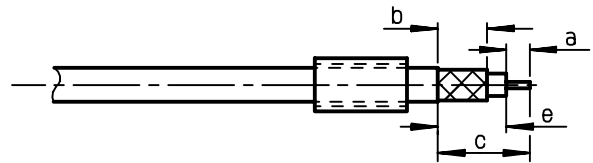

Stripping	a	b	c	d	e
inch	0.276	0.335	1.024	0	0.748
mm	7	8.5	26		19

②

Fan the braid .  
Slide the back body between dielectric and braid .  
Slide ferrule over the braid .  
(In direction F)

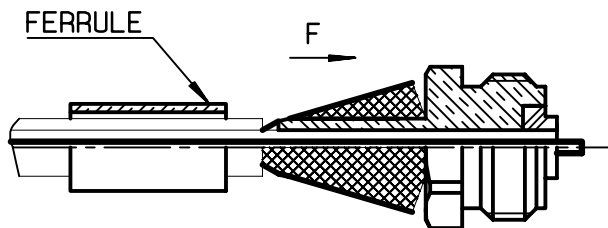

③

Crimp the ferrule with crimping tool R 282 223 000 ( Hex. : .213 ) or crimping tool R 282 293 000 ( M22520/5-01 ) + dies R 282 235 011 ( M22520/5-11 )  
Slide on the centre contact until it bottoms against insulator.  
Crimp centre contact with crimping tool R 282 223 000 ( Hex. : .068 ) or + dies R 282 235 011 ( M22520/5-11 )

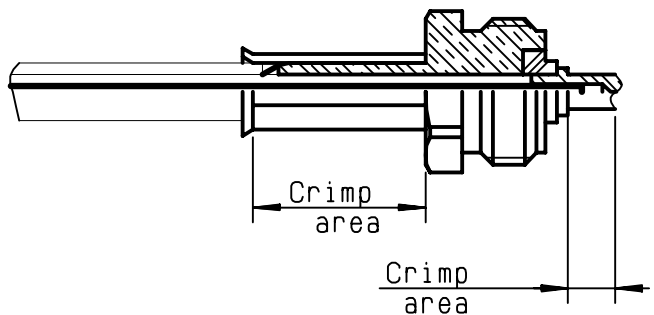

④

Mount gasket into connector .  
Screw sub-assembly into the connector body .  
( recommended coupling torque 450 N.cm )  
- 39.825 in.lb

