

REVISIONS					
REV	ECO	DESCRIPTION	DATE	BY	APPR
A1	-	RELEASE NEW DRAWING	28MAR22	VITO	TOMMY

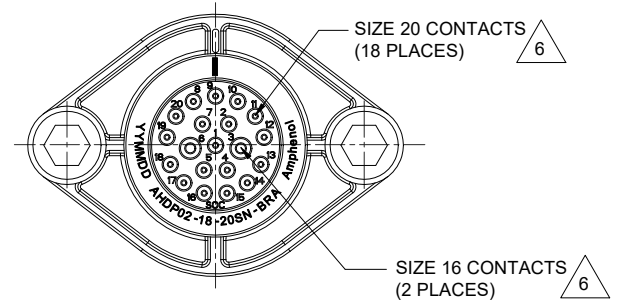
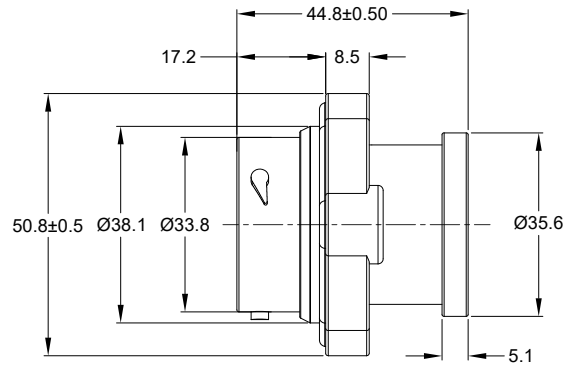
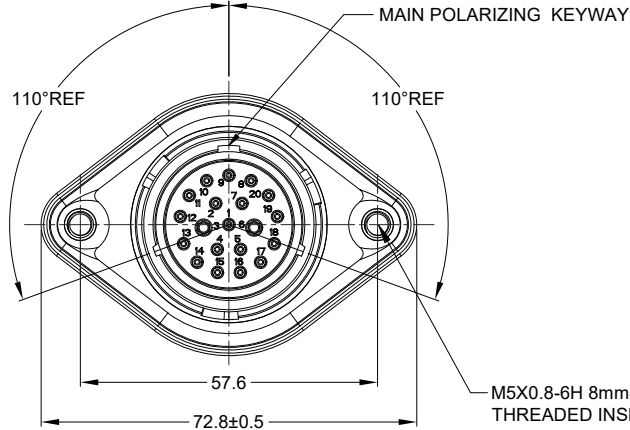

NOTES: UNLESS OTHERWISE SPECIFIED

- MATERIAL:
HOUSING: THERMOPLASTIC; BLACK
SEAL: SILICONE RUBBER
THREADED INSERT: STAINLESS STEEL

- MODIFICATIONS: BACKSHELL RING ADAPTER (BRA);
STANDARD DIA. WIRE SEAL;
SEALED PANEL MOUNT

- SPECIFICATIONS:
3.1 OPERATING TEMPERATURE: -55°C TO +125°C.
3.2 DIELECTRIC WITHSTANDING VOLTAGE: LESS THAN 2 MILLIAMPS CURRENT LEAKAGE @ 1500 VOLTS AC.
3.3 INSULATION RESISTANCE: 1000 MEGOHM MIN @ 25°C.
3.4 MOISTURE RESISTANCE:
IP68 (IM OF WATER FOR A PERIOD OF 24 HOURS, MATED CONDITION);
IP69K (MATED CONDITION)
3.5 MATING CYCLE DURABILITY: 100 CYCLES
3.6 RoHS COMPLIANT

- MATING PART: AHDP06-18-20P* (* = SEAL TYPE)

- ALL DIMENSIONS ARE FOR REFERENCE USE ONLY.

6 CONTACT SIZE AND WIRE RANGE:

CONTACT SIZE	MIN. INSUL O.D.	MAX. INSUL O.D.	TYPICAL WIRE RANGE	CURRENT RATING
16	2.54 mm (.100 in)	3.40 mm (.134 in)	14-20 AWG (2.0-0.5mm ²)	13 AMPS
20	1.02 mm (.040 in)	2.41 mm (.095 in)	16-22 AWG (1.5-0.35mm ²)	7.5 AMPS

M5X0.8-6H 8mm(2X) DEEP THREADED INSERT

RECOMMENDED TORQUE VALUES: 1.9-2.2 N.m

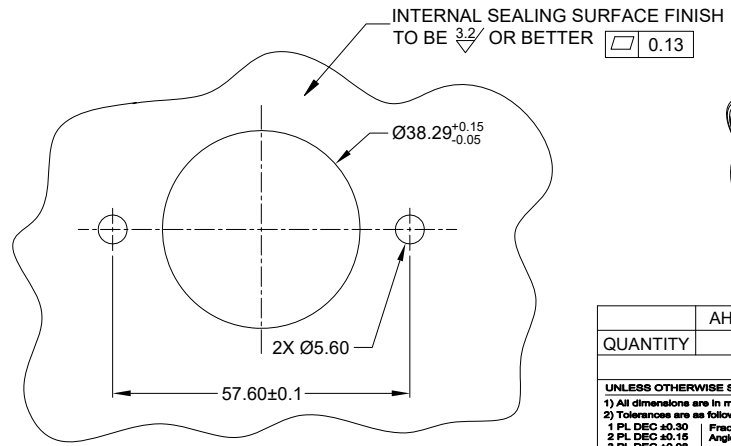

RECOMMENDED PANEL MOUNTING HOLE

RECOMMENDED PANEL THICKNESS: 1.6 TO 4.7MM

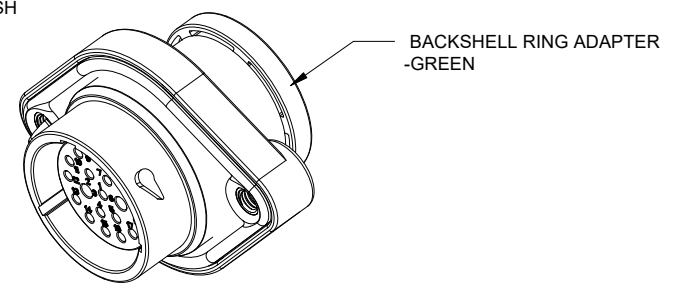

QUANTITY	AHDP02-18-20SN-SRA	DESCRIPTION	ITEM
	PART NUMBER		

MATERIALS LIST			
UNLESS OTHERWISE SPECIFIED 1) All dimensions are in metric (mm). 2) Tolerances are as follows: 1 PL DEC ±0.30 Fractions ±1/64 2 PL DEC ±0.15 Angles ±1° 3 PL DEC ±0.08 3) Note reference =		SIGNATURES DATE DRAWN: VITOLI 28MAR22 CHECKED: SULLENZHANG 28MAR22 ENGINEER: APPROVAL: TOMMY XIE 30MAR22 CUSTOMER:	
MATERIAL SPECIFICATIONS: WEIGHT: 53.8g		 Sine Systems - www.amphenol-sine.com 44724 Morley Drive Clinton Township, MI 48036	
PROCESS SPECIFICATIONS:		THIS DRAWING IS SUPPLIED FOR INFORMATION ONLY. DESIGN FEATURES, SPECIFICATIONS AND PERFORMANCE DATA SHOWN HEREON ARE THE PROPERTY OF THE AMPHENOL CORPORATION. NO RIGHTS OF REPRODUCTION ARE IMPLIED. ALL DIMENSIONS ARE SUBJECT TO NORMAL MANUFACTURING VARIATIONS.	
NEXT ASSY:		SCALE: NONE DURAMATE SHEET 1 OF 1	

TITLE: 20 POS. RECEPTACLE SOCKET PANELMATE AHDP SIZE 18, NORMAL SEAL, BRA
 DWG NO: AHDP02-18-20SN-BRA
 REV: A1
 SH: 1
 OF: 1