

FEATURES

8-bit half-flash ADC with 420 ns conversion time

Eight single-ended analog input channels

Available with input offset adjust

On-chip track-and-hold

SNR performance given for input frequencies up to 10 MHz

On-chip reference (2.5 V)

Automatic power-down at the end of conversion

Wide operating supply range

3 V \pm 10% and 5 V \pm 10%

Input ranges

0 V to 2 V p-p, V_{DD} = 3 V \pm 10%

0 V to 2.5 V p-p, V_{DD} = 5 V \pm 10%

Flexible parallel interface with \overline{EOC} pulse to allow stand-alone operation

APPLICATIONS

Data acquisition systems, DSP front ends

Disk drives

Mobile communication systems, subsampling applications

GENERAL DESCRIPTION

The AD7829-1 is a high speed 8-channel, microprocessor-compatible, 8-bit analog-to-digital converter with a maximum throughput of 2 MSPS. The AD7829-1 contains an on-chip reference of 2.5 V (2% tolerance); a track-and-hold amplifier; a 420 ns, 8-bit half-flash ADC; and a high speed parallel interface. The converter can operate from a single 3 V \pm 10% and 5 V \pm 10% supply.

The AD7829-1 combines the convert start and power-down functions at one pin, that is, the \overline{CONVST} pin. This allows a unique automatic power-down at the end of a conversion to be implemented. The logic level on the \overline{CONVST} pin is sampled after the end of a conversion when an \overline{EOC} (end of conversion) signal goes high, and if it is logic low at that point, the ADC is powered down. The parallel interface is designed to allow easy interfacing to microprocessors and DSPs. Using only address decoding logic, the parts are easily mapped into the microprocessor address space.

The \overline{EOC} pulse allows the ADCs to be used in a stand-alone manner (see the Parallel Interface section).

Rev. 0

Information furnished by Analog Devices is believed to be accurate and reliable. However, no responsibility is assumed by Analog Devices for its use, nor for any infringements of patents or other rights of third parties that may result from its use. Specifications subject to change without notice. No license is granted by implication or otherwise under any patent or patent rights of Analog Devices. Trademarks and registered trademarks are the property of their respective owners.

FUNCTIONAL BLOCK DIAGRAM

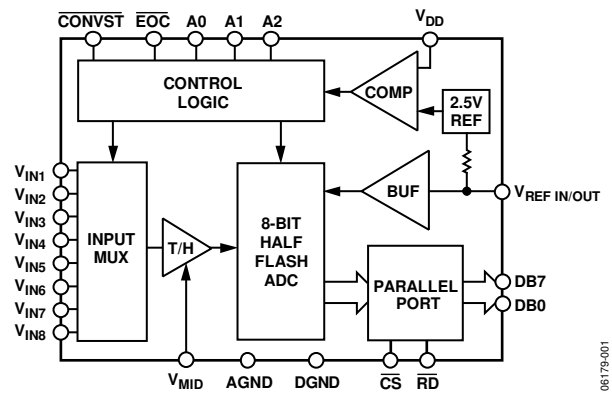

Figure 1.

The AD7829-1 is available in a 28-lead, wide body, small outline IC (SOIC_W) and a 28-lead thin shrink small outline package (TSSOP).

PRODUCT HIGHLIGHTS

1. **Fast Conversion Time.** The AD7829-1 has a conversion time of 420 ns. Faster conversion times maximize the DSP processing time in a real-time system.
2. **Analog Input Span Adjustment.** The V_{MID} pin allows the user to offset the input span. This feature can reduce the requirements of single-supply op amps and take into account any system offsets.
3. **FPBW (Full Power Bandwidth) of Track-and-Hold.** The track-and-hold amplifier has excellent high frequency performance. The AD7829-1 is capable of converting full-scale input signals up to a frequency of 10 MHz, making the parts ideally suited to subsampling applications.
4. **Channel Selection.** Channel selection is made without the necessity of writing to the part.

TABLE OF CONTENTS

Features	1	Typical Connection Diagram	10
Applications.....	1	ADC Transfer Function.....	11
General Description	1	Analog Input	11
Functional Block Diagram	1	Power-Up Times.....	14
Product Highlights	1	Power vs. Throughput.....	14
Revision History	2	Operating Modes.....	15
Specifications.....	3	Parallel Interface.....	17
Timing Characteristics	5	Microprocessor Interfacing.....	18
Timing Diagram	5	AD7829-1 to 8051	18
Absolute Maximum Ratings.....	6	AD7829-1 to PIC16C6x/PIC16C7x.....	18
ESD Caution.....	6	AD7829-1 to ADSP-21xx	18
Pin Configuration and Function Descriptions.....	7	Interfacing Multiplexer Address Inputs	18
Terminology	8	Outline Dimensions	20
Circuit Information	10	Ordering Guide	20
Circuit Description.....	10		

REVISION HISTORY

7/06—Revision 0: Initial Version

SPECIFICATIONS

$V_{DD} = 3\text{ V} \pm 10\%$, $V_{DD} = 5\text{ V} \pm 10\%$, $GND = 0\text{ V}$, $V_{REF\ IN/OUT} = 2.5\text{ V}$. All specifications -40°C to $+85^{\circ}\text{C}$, unless otherwise noted.

Table 1.

Parameter	Version B	Unit	Test Conditions/Comments
DYNAMIC PERFORMANCE			
Signal to (Noise + Distortion) Ratio ¹	48	dB min	$f_{IN} = 30\text{ kHz}$, $f_{SAMPLE} = 2\text{ MHz}$
Total Harmonic Distortion ¹	-55	dB max	
Peak Harmonic or Spurious Noise ¹	-55	dB max	
Intermodulation Distortion ¹			$f_a = 27.3\text{ kHz}$, $f_b = 28.3\text{ kHz}$
2nd Order Terms	-65	dB typ	
3rd Order Terms	-65	dB typ	
Channel-to-Channel Isolation ¹	-70	dB typ	$f_{IN} = 20\text{ kHz}$
DC ACCURACY			
Resolution	8	Bits	
Minimum Resolution for Which No Missing Codes Are Guaranteed	8	Bits	
Integral Nonlinearity (INL) ¹	± 0.75	LSB max	
Differential Nonlinearity (DNL) ¹	± 0.75	LSB max	
Gain Error ¹	± 2	LSB max	
Gain Error Match ¹	± 0.1	LSB typ	
Offset Error ¹	± 1	LSB max	
Offset Error Match ¹	± 0.1	LSB typ	
ANALOG INPUTS²			
$V_{DD} = 5\text{ V} \pm 10\%$			See Analog Input section
V_{IN1} to V_{IN8} Input Voltage	V_{DD}	V max	Input voltage span = 2.5 V
	0	V min	
V_{MID} Input Voltage	$V_{DD} - 1.25$	V max	Default $V_{MID} = 1.25\text{ V}$
	1.25	V min	
$V_{DD} = 3\text{ V} \pm 10\%$			Input voltage span = 2 V
V_{IN1} to V_{IN8} Input Voltage	V_{DD}	V max	
	0	V min	
V_{MID} Input Voltage	$V_{DD} - 1$	V max	Default $V_{MID} = 1\text{ V}$
	1	V min	
V_{IN} Input Leakage Current	± 1	μA max	
V_{IN} Input Capacitance	15	pF max	
V_{MID} Input Impedance	6	k Ω typ	
REFERENCE INPUT			
$V_{REF\ IN/OUT}$ Input Voltage Range	2.55	V max	2.5 V + 2%
	2.45	V min	2.5 V - 2%
Input Current	1	μA typ	
	100	μA max	
ON-CHIP REFERENCE			
Reference Error	± 50	mV max	Nominal 2.5 V
Temperature Coefficient	50	ppm/ $^{\circ}\text{C}$ typ	
LOGIC INPUTS			
Input High Voltage, V_{INH}	2.4	V min	$V_{DD} = 5\text{ V} \pm 10\%$
Input Low Voltage, V_{INL}	0.8	V max	$V_{DD} = 5\text{ V} \pm 10\%$
Input High Voltage, V_{INH}	2	V min	$V_{DD} = 3\text{ V} \pm 10\%$
Input Low Voltage, V_{INL}	0.4	V max	$V_{DD} = 3\text{ V} \pm 10\%$
Input Current, I_{IN}	± 1	μA max	Typically 10 nA, $V_{IN} = 0\text{ V}$ to V_{DD}
Input Capacitance, C_{IN}	10	pF max	

AD7829-1

Parameter	Version B	Unit	Test Conditions/Comments	
LOGIC OUTPUTS				
Output High Voltage, V_{OH}	4 2.4	V min V min	$I_{SOURCE} = 200 \mu A$ $V_{DD} = 5 V \pm 10\%$ $V_{DD} = 3 V \pm 10\%$	
Output Low Voltage, V_{OL}	0.4 0.2	V max V max	$I_{SINK} = 200 \mu A$ $V_{DD} = 5 V \pm 10\%$ $V_{DD} = 3 V \pm 10\%$	
High Impedance Leakage Current	± 1	μA max		
High Impedance Capacitance	10	pF max		
CONVERSION RATE				
Track/Hold Acquisition Time	200	ns max	See Circuit Description section	
Conversion Time	420	ns max		
POWER SUPPLY REJECTION				
$V_{DD} \pm 10\%$	± 1	LSB max		
POWER REQUIREMENTS				
V_{DD}	4.5	V min	$5 V \pm 10\%$; for specified performance	
	5.5	V max		
V_{DD}	2.7	V min	$3 V \pm 10\%$; for specified performance	
	3.3	V max		
I_{DD}				
	Normal Operation	12	mA max	8 mA typically
	Power-Down	5	μA max	Logic inputs = 0 V or V_{DD}
Power Dissipation				
	Normal Operation	0.2	μA typ	$V_{DD} = 3 V$
	Power-Down	36	mW max	Typically 24 mW
200 kSPS	9.58	mW typ		
500 kSPS	23.94	mW typ		

¹ See the Terminology section of this data sheet.

² Refer to the Analog Input section for an explanation of the analog input(s).

TIMING CHARACTERISTICS

$V_{REF\ IN/OUT} = 2.5\text{ V}$. All specifications -40°C to $+85^{\circ}\text{C}$, unless otherwise noted.

Table 2.

Parameter ^{1,2}	5 V \pm 10%	3 V \pm 10%	Unit	Description
t_1	420	420	ns max	Conversion time
t_2	20	20	ns min	Minimum $\overline{\text{CONVST}}$ pulse width
t_3	30	30	ns min	Minimum time between the rising edge of $\overline{\text{RD}}$ and the next falling edge of convert start
t_4	110	110	ns max	$\overline{\text{EOC}}$ pulse width
	70	70	ns min	
t_5	10	10	ns max	$\overline{\text{RD}}$ rising edge to $\overline{\text{EOC}}$ pulse high
t_6	0	0	ns min	$\overline{\text{CS}}$ to $\overline{\text{RD}}$ setup time
t_7	0	0	ns min	$\overline{\text{CS}}$ to $\overline{\text{RD}}$ hold time
t_8	30	30	ns min	Minimum $\overline{\text{RD}}$ pulse width
t_9^3	10	20	ns max	Data access time after $\overline{\text{RD}}$ low
t_{10}^4	5	5	ns min	Bus relinquish time after $\overline{\text{RD}}$ high
	20	20	ns max	
t_{11}	10	10	ns min	Address setup time before the falling edge of $\overline{\text{RD}}$
t_{12}	15	15	ns min	Address hold time after the falling edge of $\overline{\text{RD}}$
t_{13}	200	200	ns min	Minimum time between new channel selection and convert start
$t_{\text{POWER UP}}$	25	25	$\mu\text{s typ}$	Power-up time from the rising edge of $\overline{\text{CONVST}}$ using on-chip reference
$t_{\text{POWER UP}}$	1	1	$\mu\text{s max}$	Power-up time from the rising edge of $\overline{\text{CONVST}}$ using external 2.5 V reference

¹ Sample tested to ensure compliance.

² See Figure 21, Figure 22, and Figure 23.

³ Measured with the load circuit of Figure 2 and defined as the time required for an output to cross 0.8 V or 2.4 V with $V_{DD} = 5\text{ V} \pm 10\%$, and the time required for an output to cross 0.4 V or 2.0 V with $V_{DD} = 3\text{ V} \pm 10\%$.

⁴ Derived from the measured time taken by the data outputs to change 0.5 V when loaded with the circuit of Figure 2. The measured number is then extrapolated back to remove the effects of charging or discharging the 50 pF capacitor. This means that the time, t_{10} , quoted in the timing characteristics is the true bus relinquish time of the part and, as such, is independent of external bus loading capacitances.

TIMING DIAGRAM

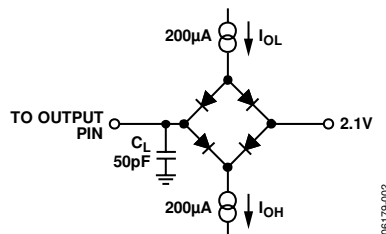

Figure 2. Load Circuit for Access Time and Bus Relinquish Time

ABSOLUTE MAXIMUM RATINGS

T_A = 25°C, unless otherwise noted.

Table 3.

Parameter	Rating
V _{DD} to AGND	−0.3 V to +7 V
V _{DD} to DGND	−0.3 V to +7 V
Analog Input Voltage to AGND V _{IN1} to V _{IN8}	−0.3 V to V _{DD} + 0.3 V
Reference Input Voltage to AGND	−0.3 V to V _{DD} + 0.3 V
V _{MID} Input Voltage to AGND	−0.3 V to V _{DD} + 0.3 V
Digital Input Voltage to DGND	−0.3 V to V _{DD} + 0.3 V
Digital Output Voltage to DGND	−0.3 V to V _{DD} + 0.3 V
Operating Temperature Range	
Industrial (B Version)	−40°C to +85°C
Storage Temperature Range	−65°C to +150°C
Junction Temperature	150°C
SOIC Package, Power Dissipation	450 mW
θ _{JA} Thermal Impedance	75°C/W
Lead Temperature, Soldering	
Vapor Phase (60 sec)	215°C
Infrared (15 sec)	220°C
TSSOP Package, Power Dissipation	450 mW
θ _{JA} Thermal Impedance	128°C/W
Lead Temperature, Soldering	
Vapor Phase (60 sec)	215°C
Infrared (15 sec)	220°C
ESD	1 kV

Stresses above those listed under Absolute Maximum Ratings may cause permanent damage to the device. This is a stress rating only; functional operation of the device at these or any other conditions above those indicated in the operational section of this specification is not implied. Exposure to absolute maximum rating conditions for extended periods may affect device reliability.

ESD CAUTION

ESD (electrostatic discharge) sensitive device. Electrostatic charges as high as 4000 V readily accumulate on the human body and test equipment and can discharge without detection. Although this product features proprietary ESD protection circuitry, permanent damage may occur on devices subjected to high energy electrostatic discharges. Therefore, proper ESD precautions are recommended to avoid performance degradation or loss of functionality.



PIN CONFIGURATION AND FUNCTION DESCRIPTIONS

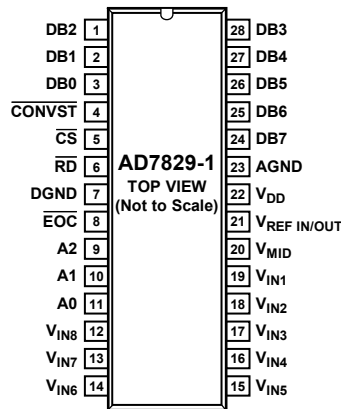

Figure 3. Pin Configuration

Table 4. Pin Function Descriptions

Pin No.	Mnemonic	Description
12 to 19	V_{IN8} to V_{IN1}	Analog Input Channels. The AD7829-1 has eight analog input channels. The inputs have an input span of 2.5 V and 2 V, depending on the supply voltage (V_{DD}). This span can be centered anywhere in the range AGND to V_{DD} using the V_{MID} pin. The default input range (V_{MID} unconnected) is AGND to 2 V ($V_{DD} = 3 V \pm 10\%$) or AGND to 2.5 V ($V_{DD} = 5 V \pm 10\%$). See the Analog Input section of the data sheet for more information.
22	V_{DD}	Positive Supply Voltage, 3 V \pm 10% and 5 V \pm 10%.
23	AGND	Analog Ground. Ground reference for track/hold, comparators, reference circuit, and multiplexer.
7	DGND	Digital Ground. Ground reference for digital circuitry.
4	\overline{CONVST}	Logic Input Signal. The convert start signal initiates an 8-bit analog-to-digital conversion on the falling edge of this signal. The falling edge of this signal places the track/hold in hold mode. The track/hold goes into track mode again 120 ns after the start of a conversion. The state of the \overline{CONVST} signal is checked at the end of a conversion. If it is logic low, the AD7829-1 powers down (see the Operating Modes section).
8	\overline{EOC}	Logic Output. The end of conversion signal indicates when a conversion has finished. The signal can be used to interrupt a microcontroller when a conversion has finished or latch data into a gate array (see the Parallel Interface section).
5	\overline{CS}	Logic Input Signal. The chip select signal is used to enable the parallel port of the AD7829. This is necessary if the ADC is sharing a common data bus with another device.
6	\overline{RD}	Logic Input Signal. The read signal is used to take the output buffers out of their high impedance state and drive data onto the data bus. The signal is internally gated with the \overline{CS} signal. Both \overline{RD} and \overline{CS} must be logic low to enable the data bus.
9 to 11	A2 to A0	Channel Address Inputs. The address of the next multiplexer channel must be present on these inputs when the \overline{RD} signal goes low.
1 to 3, 24 to 28	DB2 to DB0, DB7 to DB3	Data Output Lines. They are normally held in a high impedance state. Data is driven onto the data bus when both \overline{RD} and \overline{CS} go active low.
21	$V_{REF IN/OUT}$	Analog Input and Output. An external reference can be connected to the AD7829-1 at this pin. The on-chip reference is also available at this pin. When using the internal reference, this pin can be left unconnected or, in some cases, it can be decoupled to AGND with a 0.1 μ F capacitor.
20	V_{MID}	The V_{MID} pin, if connected, is used to center the analog input span anywhere in the range of AGND to V_{DD} (see the Analog Input section).

TERMINOLOGY

Signal-to-(Noise + Distortion) Ratio

The measured ratio of signal-to-(noise + distortion) at the output of the A/D converter. The signal is the rms amplitude of the fundamental. Noise is the rms sum of all nonfundamental signals up to half the sampling frequency ($f_s/2$), excluding dc. The ratio is dependent upon the number of quantization levels in the digitization process; the more levels, the smaller the quantization noise. The theoretical signal-to-(noise + distortion) ratio for an ideal N-bit converter with a sine wave input is given by

$$\text{Signal-to-(Noise + Distortion)} = (6.02N + 1.76) \text{ dB}$$

Thus, for an 8-bit converter, this is 50 dB.

Total Harmonic Distortion (THD)

The ratio of the rms sum of harmonics to the fundamental. For the AD7829-1 it is defined as

$$\text{THD (dB)} = 20 \log \frac{\sqrt{V_2^2 + V_3^2 + V_4^2 + V_5^2 + V_6^2}}{V_1}$$

where V_1 is the rms amplitude of the fundamental, and V_2 , V_3 , V_4 , V_5 , and V_6 are the rms amplitudes of the second through the sixth harmonics.

Peak Harmonic or Spurious Noise

The ratio of the rms value of the next largest component in the ADC output spectrum (up to $f_s/2$ and excluding dc) to the rms value of the fundamental. Normally, the value of this specification is determined by the largest harmonic in the spectrum, but for parts where the harmonics are buried in the noise floor, it will be a noise peak.

Intermodulation Distortion

With inputs consisting of sine waves at two frequencies, f_a and f_b , any active device with nonlinearities creates distortion products at sum and difference frequencies of $m f_a \pm n f_b$, where $m, n = 0, 1, 2, 3, \dots$. Intermodulation terms are those for which neither m nor n is equal to zero. For example, the second order terms include $(f_a + f_b)$ and $(f_a - f_b)$, while the third order terms include $(2f_a + f_b)$, $(2f_a - f_b)$, $(f_a + 2f_b)$, and $(f_a - 2f_b)$. The AD7829-1 is tested using the CCIF standard, where two input frequencies near the top end of the input bandwidth are used. In this case, the second and third order terms are of different significance. The second order terms are usually distanced in frequency from the original sine waves, while the third order terms are usually at a frequency close to the input frequencies.

As a result, the second and third order terms are specified separately. The calculation of the intermodulation distortion is as per the THD specification, where it is the ratio of the rms sum of the individual distortion products to the rms amplitude of the fundamental expressed in decibels (dB).

Channel-to-Channel Isolation

A measure of the level of crosstalk between channels. It is measured by applying a full-scale 20 kHz sine wave signal to one input channel and determining how much that signal is attenuated in each of the other channels. The figure given is the worst case across all eight channels of the AD7829-1.

Relative Accuracy or Endpoint Nonlinearity

The maximum deviation from a straight line passing through the endpoints of the ADC transfer function.

Differential Nonlinearity

The difference between the measured and the ideal 1 LSB change between any two adjacent codes in the ADC.

Offset Error

The deviation of the 128th code transition (01111111) to (10000000) from the ideal, that is, V_{MID} .

Offset Error Match

The difference in offset error between any two channels.

Zero-Scale Error

The deviation of the first code transition (00000000) to (00000001) from the ideal; that is, $V_{\text{MID}} - 1.25 \text{ V} + 1 \text{ LSB}$ ($V_{\text{DD}} = 5 \text{ V} \pm 10\%$), or $V_{\text{MID}} - 1.0 \text{ V} + 1 \text{ LSB}$ ($V_{\text{DD}} = 3 \text{ V} \pm 10\%$).

Full-Scale Error

The deviation of the last code transition (11111110) to (11111111) from the ideal; that is, $V_{\text{MID}} + 1.25 \text{ V} - 1 \text{ LSB}$ ($V_{\text{DD}} = 5 \text{ V} \pm 10\%$), or $V_{\text{MID}} + 1.0 \text{ V} - 1 \text{ LSB}$ ($V_{\text{DD}} = 3 \text{ V} \pm 10\%$).

Gain Error

The deviation of the last code transition (1111 . . . 110) to (1111 . . . 111) from the ideal; that is, $V_{\text{REF}} - 1 \text{ LSB}$, after the offset error has been adjusted out.

Gain Error Match

The difference in gain error between any two channels.

Track/Hold Acquisition Time

The time required for the output of the track/hold amplifier to reach its final value, within $\pm 1/2$ LSB, after the point at which the track/hold returns to track mode. This happens approximately 120 ns after the falling edge of CONVST.

It also applies to situations where a change in the selected input channel takes place or where there is a step input change on the input voltage applied to the selected V_{IN} input of the AD7829-1.

It means that the user must wait for the duration of the track/hold acquisition time after a channel change/step input change to V_{IN} before starting another conversion, to ensure that the part operates to specification.

PSR (Power Supply Rejection)

Variations in power supply affect the full-scale transition but not the converter's linearity. Power supply rejection is the maximum change in the full-scale transition point due to a change in power supply voltage from the nominal value.

CIRCUIT INFORMATION

CIRCUIT DESCRIPTION

The AD7829-1 consists of a track-and-hold amplifier followed by a half-flash analog-to-digital converter. These devices use a half-flash conversion technique where one 4-bit flash ADC is used to achieve an 8-bit result. The 4-bit flash ADC contains a sampling capacitor followed by 15 comparators that compare the unknown input to a reference ladder to achieve a 4-bit result. This first flash, that is, coarse conversion, provides the four MSBs. For a full 8-bit reading to be realized, a second flash, that is, a fine conversion, must be performed to provide the four LSBs. The 8-bit word is then placed on the data output bus.

Figure 4 and Figure 5 show simplified schematics of the ADC. When the ADC starts a conversion, the track-and-hold goes into hold mode and holds the analog input for 120 ns. This is the acquisition phase as shown in Figure 4, when Switch 2 is in Position A. At the point when the track-and-hold returns to its track mode, this signal is sampled by the sampling capacitor as Switch 2 moves into Position B. The first flash occurs at this instant and is then followed by the second flash. Typically, the first flash is complete after 100 ns, that is, at 220 ns, while the end of the second flash and, hence, the 8-bit conversion result, is available at 330 ns (minimum). The maximum conversion time is 420 ns. As shown in Figure 6, the track-and-hold returns to track mode after 120 ns and starts the next acquisition before the end of the current conversion. Figure 8 shows the ADC transfer function.

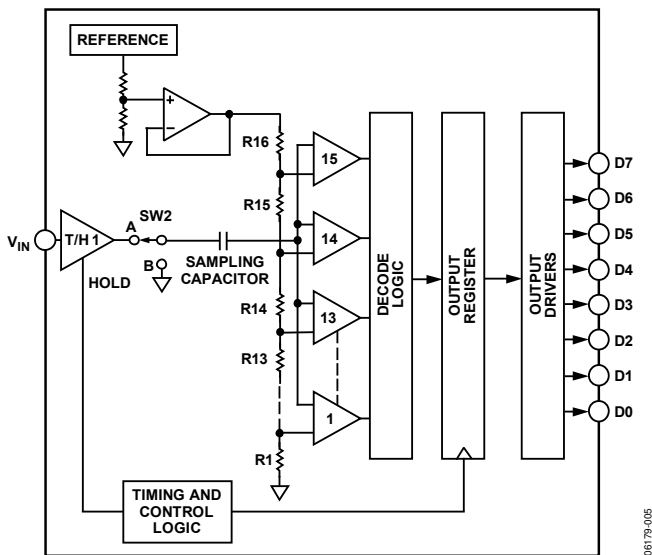

Figure 4. ADC Acquisition Phase

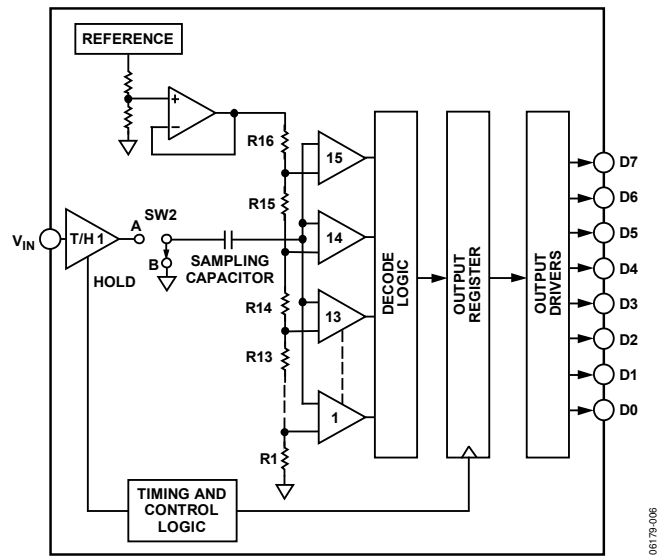

Figure 5. ADC Conversion Phase

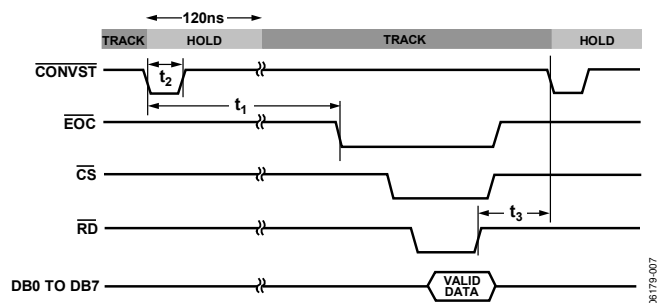

Figure 6. Track-and-Hold Timing

TYPICAL CONNECTION DIAGRAM

Figure 7 shows a typical connection diagram for the AD7829-1. The AGND and DGND are connected together at the device for good noise suppression. The parallel interface is implemented using an 8-bit data bus. The end of conversion signal (EOC) idles high, the falling edge of $\overline{\text{CONVST}}$ initiates a conversion, and at the end of conversion the falling edge of $\overline{\text{EOC}}$ is used to initiate an interrupt service routine (ISR) on a microprocessor (see the Parallel Interface section). $V_{\text{REF IN/OUT}}$ and V_{MID} are connected to a voltage source, such as the AD780, while V_{DD} is connected to a voltage source that can vary from 4.5 V to 5.5 V (see Table 5 in the Analog Input section). When V_{DD} is first connected, the AD7829-1 powers up in a low current mode, that is, power-down. Ensure that the $\overline{\text{CONVST}}$ line is not floating when V_{DD} is applied, because this can put the AD7829-1 into an unknown state.

A suggestion is to tie $\overline{\text{CONVST}}$ to V_{DD} or DGND through a pull-up or pull-down resistor. A rising edge on the $\overline{\text{CONVST}}$ pin causes the AD7829-1 to fully power up. For applications where power consumption is of concern, the automatic power-down at the end of a conversion should be used to improve power performance (see the Power vs. Throughput section). If the AD7829-1 is operated outside normal V_{DD} limits (for example, a brown-out), it may take two conversions to reset the part once the correct V_{DD} has been established.

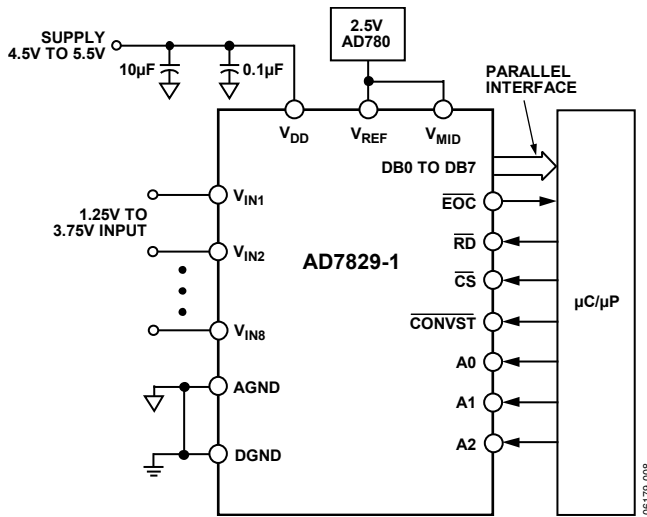

Figure 7. Typical Connection Diagram

ADC TRANSFER FUNCTION

The output coding of the AD7829-1 is straight binary. The designed code transitions occur at successive integer LSB values (that is, 1 LSB, 2 LSBs, and so on). The LSB size is equal to $V_{\text{REF}}/256$ ($V_{\text{DD}} = 5 \text{ V}$), or the LSB size is equal to $(0.8 V_{\text{REF}})/256$ ($V_{\text{DD}} = 3 \text{ V}$). The ideal transfer characteristic for the AD7829-1 is shown in Figure 8.

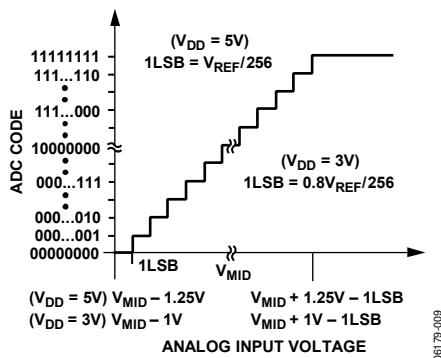

Figure 8. Transfer Characteristic

ANALOG INPUT

The AD7829-1 has eight input channels. Each input channel has an input span of 2.5 V or 2.0 V, depending on the supply voltage (V_{DD}). This input span is automatically set up by an on-chip “ V_{DD} detector” circuit. A 5 V operation of the ADCs is detected when V_{DD} exceeds 4.1 V, and a 3 V operation is detected when V_{DD} falls below 3.8 V. This circuit also possesses a degree of glitch rejection; for example, a glitch from 5.5 V to 2.7 V up to 60 ns wide does not trip the V_{DD} detector.

The V_{MID} pin is used to center this input span anywhere in the range of AGND to V_{DD} . If no input voltage is applied to V_{MID} , the default input range is AGND to 2.0 V ($V_{\text{DD}} = 3 \text{ V} \pm 10\%$), that is, centered about 1.0 V; or AGND to 2.5 V ($V_{\text{DD}} = 5 \text{ V} \pm 10\%$), that is, centered about 1.25 V. When using the default input range, the V_{MID} pin can be left unconnected; or, in some cases, it can be decoupled to AGND with a 0.1 μF capacitor.

If, however, an external V_{MID} is applied, the analog input range is from $V_{\text{MID}} - 1.0 \text{ V}$ to $V_{\text{MID}} + 1.0 \text{ V}$ ($V_{\text{DD}} = 3 \text{ V} \pm 10\%$), or from $V_{\text{MID}} - 1.25 \text{ V}$ to $V_{\text{MID}} + 1.25 \text{ V}$ ($V_{\text{DD}} = 5 \text{ V} \pm 10\%$).

The range of values of V_{MID} that can be applied depends on the value of V_{DD} . For $V_{\text{DD}} = 3 \text{ V} \pm 10\%$, the range of values that can be applied to V_{MID} is from 1.0 V to $V_{\text{DD}} - 1.0 \text{ V}$ and is 1.25 V to $V_{\text{DD}} - 1.25 \text{ V}$ when $V_{\text{DD}} = 5 \text{ V} \pm 10\%$. Table 5 shows the relevant ranges of V_{MID} and the input span for various values of V_{DD} . Figure 9 illustrates the input signal range available with various values of V_{MID} .

Table 5.

V_{DD}	V_{MID} Internal	V_{MID} Ext Maximum	V_{IN} Span	V_{MID} Ext Minimum	V_{IN} Span
5.5	1.25	4.25	3.0 to 5.5	1.25	0 to 2.5
5.0	1.25	3.75	2.5 to 5.0	1.25	0 to 2.5
4.5	1.25	3.25	2.0 to 4.5	1.25	0 to 2.5
3.3	1.00	2.3	1.3 to 3.3	1.00	0 to 2.0
3.0	1.00	2.0	1.0 to 3.0	1.00	0 to 2.0
2.7	1.00	1.7	0.7 to 2.7	1.00	0 to 2.0

AD7829-1

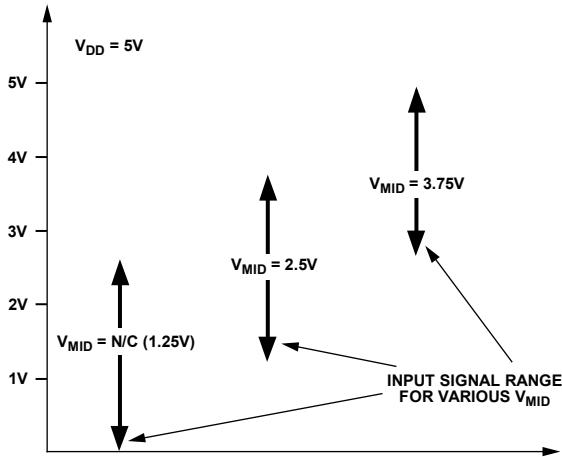

Figure 9. Analog Input Span Variation with V_{MID}

V_{MID} can be used to remove offsets in a system by applying the offset to the V_{MID} pin, as shown in Figure 10; or it can be used to accommodate bipolar signals by applying V_{MID} to a level-shifting circuit before V_{IN} , as shown in Figure 11. When V_{MID} is being driven by an external source, the source can be directly tied to the level-shifting circuitry (see Figure 11); however, if the internal V_{MID} , that is, the default value, is being used as an output, it must be buffered before applying it to the level-shifting circuitry, because the V_{MID} pin has an impedance of approximately 6 k Ω (see Figure 12).

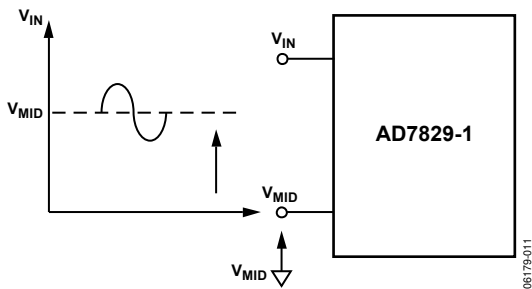

Figure 10. Removing Offsets Using V_{MID}

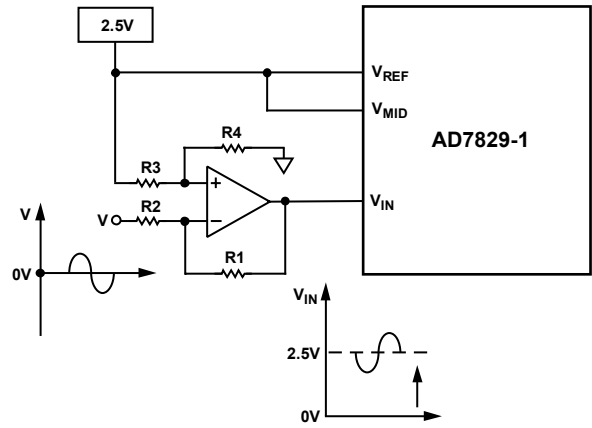

Figure 11. Accommodating Bipolar Signals Using External V_{MID}

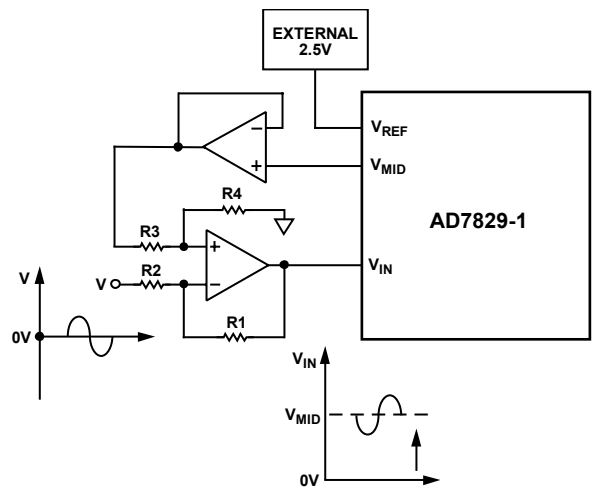

Figure 12. Accommodating Bipolar Signals Using Internal V_{MID}

NOTE: Although there is a V_{REF} pin from which a voltage reference of 2.5 V can be sourced, or to which an external reference can be applied, this does not provide an option of varying the value of the voltage reference. As stated in the specifications for the AD7829-1, the input voltage range at this pin is $2.5 \text{ V} \pm 2\%$.

Analog Input Structure

Figure 13 shows an equivalent circuit of the analog input structure of the AD7829-1. The two diodes, D1 and D2, provide ESD protection for the analog inputs. Care must be taken to ensure that the analog input signal never exceeds the supply rails by more than 200 mV. This causes these diodes to become forward biased and start conducting current into the substrate. 20 mA is the maximum current these diodes can conduct without causing irreversible damage to the part. However, it is worth noting that a small amount of current (1 mA) conducted into the substrate due to an overvoltage on an unselected channel can cause inaccurate conversions on a selected channel.

Capacitor C2 in Figure 13 is typically about 4 pF and can be primarily attributed to pin capacitance. The resistor, R1, is a lumped component made up of the on resistance of several components, including that of the multiplexer and the track-and-hold. This resistor is typically about 310 Ω. Capacitor C1 is the track-and-hold capacitor and has a capacitance of 0.5 pF. Switch 1 is the track-and-hold switch, while Switch 2 is that of the sampling capacitor, as shown in Figure 4 and Figure 5.

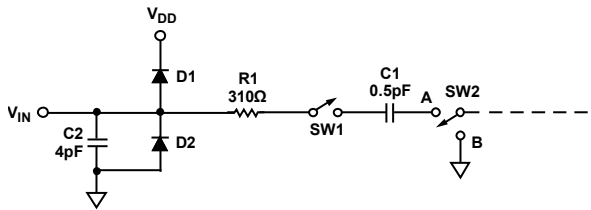

Figure 13. Equivalent Analog Input Circuit

When in track phase, Switch 1 is closed and Switch 2 is in Position A; when in hold mode, Switch 1 opens, while Switch 2 remains in Position A. The track-and-hold remains in hold mode for 120 ns (see the Circuit Description section), after which it returns to track mode and the ADC enters its conversion phase. At this point, Switch 1 opens and Switch 2 moves to Position B. At the end of the conversion, Switch 2 moves back to Position A.

Analog Input Selection

On power-up, the default VIN selection is VIN1. When returning to normal operation from power-down, the VIN selected is the same one that was selected prior to power-down being initiated. Table 6 shows the multiplexer address corresponding to each analog input from VIN1 to VIN8 for the AD7829-1.

Table 6.

A2	A1	A0	Analog Input Selected
0	0	0	VIN1
0	0	1	VIN2
0	1	0	VIN3
0	1	1	VIN4
1	0	0	VIN5
1	0	1	VIN6
1	1	0	VIN7
1	1	1	VIN8

Channel selection on the AD7829-1 is made without the necessity of a write operation. The address of the next channel to be converted is latched at the start of the current read operation, that is, on the falling edge of RD while CS is low, as shown in Figure 14. This allows for improved throughput rates in “channel hopping” applications.

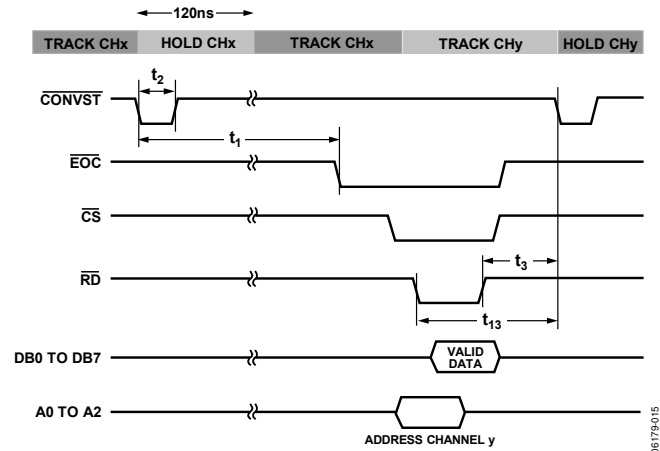

Figure 14. Channel Hopping Timing

There is a minimum time delay between the falling edge of RD and the next falling edge of the CONVST signal, t13. This is the minimum acquisition time required of the track-and-hold to maintain 8-bit performance. Figure 15 shows the typical performance of the AD7829-1 when channel hopping for various acquisition times. These results were obtained using an external reference and internal VMID while channel hopping between VIN1 and VIN4 with 0 V on Channel 4 and 0.5 V on Channel 1.

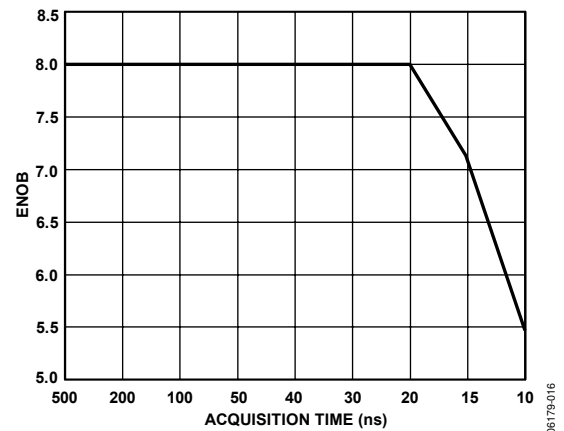

Figure 15. Effective Number of Bits vs. Acquisition Time for the AD7829-1

The on-chip track-and-hold can accommodate input frequencies to 10 MHz, making the AD7829-1 ideal for subsampling applications. When the AD7829-1 is converting a 10 MHz input signal at a sampling rate of 2 MSPS, the effective number of bits typically remains above seven, corresponding to a signal-to-noise ratio of 42 dB, as shown in Figure 16.

AD7829-1

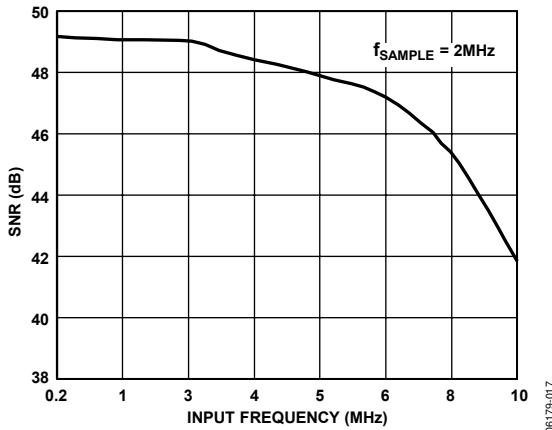

Figure 16. SNR vs. Input Frequency on the AD7829-1

POWER-UP TIMES

The AD7829-1 has a 1 μ s power-up time when using an external reference and a 25 μ s power-up time when using the on-chip reference. When V_{DD} is first connected, the AD7829-1 is in a low current mode of operation. Ensure that the $\overline{\text{CONVST}}$ line is not floating when V_{DD} is applied. If there is a glitch on $\overline{\text{CONVST}}$ while V_{DD} is rising, the part attempts to power up before V_{DD} has fully settled and may enter an unknown state. In order to carry out a conversion, the AD7829-1 must first be powered up.

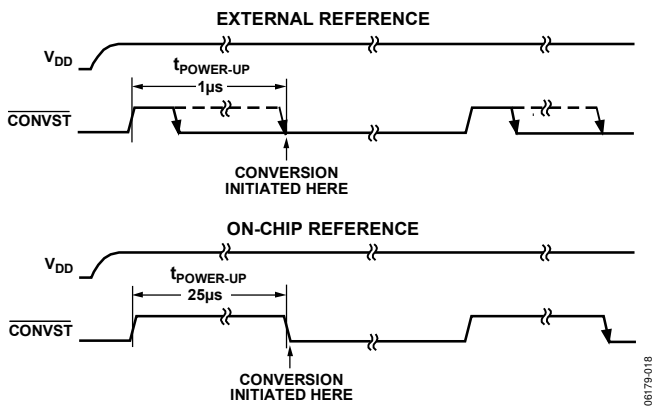

Figure 17. AD7829-1 Power-Up Time

The AD7829-1 is powered up by a rising edge on the $\overline{\text{CONVST}}$ pin. A conversion is initiated on the falling edge of $\overline{\text{CONVST}}$. Figure 17 shows how to power up the AD7829-1 when V_{DD} is first connected or after the AD7829-1 has been powered down using the $\overline{\text{CONVST}}$ pin when using either the on-chip reference or an external reference. When using an external reference, the falling edge of $\overline{\text{CONVST}}$ may occur before the required power-up time has elapsed. However, the conversion is not initiated on the falling edge of $\overline{\text{CONVST}}$ but rather at the moment when the part has completely powered up, that is, after 1 μ s.

If the falling edge of $\overline{\text{CONVST}}$ occurs after the required power-up time has elapsed, then it is upon this falling edge that a conversion is initiated. When using the on-chip reference, it is necessary to wait the required power-up time of approximately 25 μ s before initiating a conversion. That is, a falling edge on $\overline{\text{CONVST}}$ must not occur before the required power-up time has elapsed, when V_{DD} is first connected or after the AD7829-1 has been powered down using the $\overline{\text{CONVST}}$ pin, as shown in Figure 17.

POWER VS. THROUGHPUT

Superior power performance can be achieved by using the automatic power-down (Mode 2) at the end of a conversion (see the Operating Modes section).

Figure 18 shows how the automatic power-down is implemented using the $\overline{\text{CONVST}}$ signal to achieve the optimum power performance for the AD7829-1. The duration of the $\overline{\text{CONVST}}$ pulse is set to be equal to or less than the power-up time of the devices (see the Operating Modes section). As the throughput rate is reduced, the device remains in its power-down state longer, and the average power consumption over time drops accordingly.

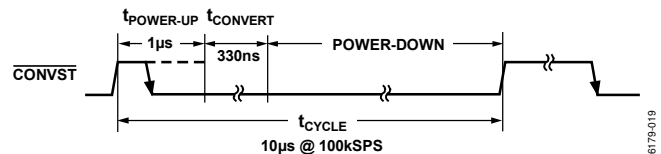

Figure 18. Automatic Power-Down

For example, if the AD7829-1 is operated in a continuous sampling mode, with a throughput rate of 100 kSPS and using an external reference, the power consumption is calculated as follows. The power dissipation during normal operation is 36 mW, $V_{DD} = 3$ V. If the power-up time is 1 μ s and the conversion time is 330 ns (@ +25°C), the AD7829-1 can be said to dissipate 36 mW (maximum) for 1.33 μ s during each conversion cycle. If the throughput rate is 100 kSPS, the cycle time is 10 μ s and the average power dissipated during each cycle is $(1.33/10) \times (36 \text{ mW}) = 4.79 \text{ mW}$. This calculation uses the minimum conversion time, thus giving the best-case power dissipation at this throughput rate. However, the actual power dissipated during each conversion cycle may increase, depending on the actual conversion time (up to a maximum of 420 ns).

Figure 19 shows the power vs. throughput rate for automatic, full power-down.

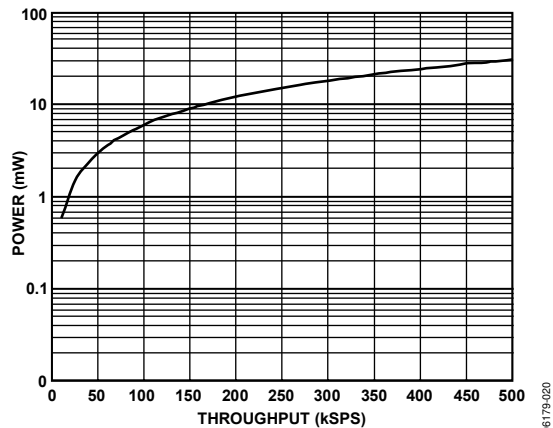

Figure 19. AD7829-1 Power vs. Throughput

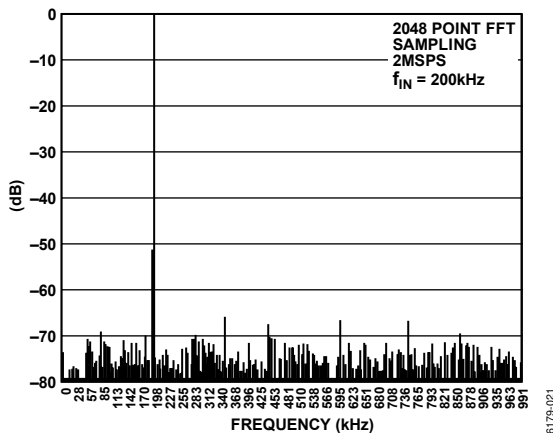

Figure 20. AD7829-1 SNR

OPERATING MODES

The AD7829-1 has two possible modes of operation, depending on the state of the $\overline{\text{CONVST}}$ pulse approximately 100 ns after the end of a conversion, that is, upon the rising edge of the $\overline{\text{EOC}}$ pulse.

Mode 1 Operation (High-Speed Sampling)

When the AD7829-1 is operated in Mode 1, it is not powered down between conversions. This mode of operation allows high throughput rates to be achieved. Figure 21 shows how this optimum throughput rate is achieved by bringing $\overline{\text{CONVST}}$ high before the end of a conversion, that is, before the $\overline{\text{EOC}}$ pulses low. When operating in this mode, a new conversion should not be initiated until 30 ns after the end of a read operation. This allows the track/hold to acquire the analog signal to 0.5 LSB accuracy.

Mode 2 Operation (Automatic Power-Down)

When the AD7829-1 is operated in Mode 2 (see Figure 22), it automatically powers down at the end of a conversion. The $\overline{\text{CONVST}}$ signal is brought low to initiate a conversion and is left logic low until after the $\overline{\text{EOC}}$ goes high, that is, approximately 100 ns after the end of the conversion. The state of the $\overline{\text{CONVST}}$ signal is sampled at this point (that is, 530 ns maximum after $\overline{\text{CONVST}}$ falling edge) and the AD7829-1 powers down as long as $\overline{\text{CONVST}}$ is low. The ADC is powered up again on the rising edge of the $\overline{\text{CONVST}}$ signal. Superior power performance can be achieved in this mode of operation by powering up the AD7829-1 only to carry out a conversion. The parallel interface of the AD7829-1 is still fully operational while the ADCs are powered down. A read can occur while the part is powered down, and so it does not necessarily need to be placed within the $\overline{\text{EOC}}$ pulse, as shown in Figure 22.

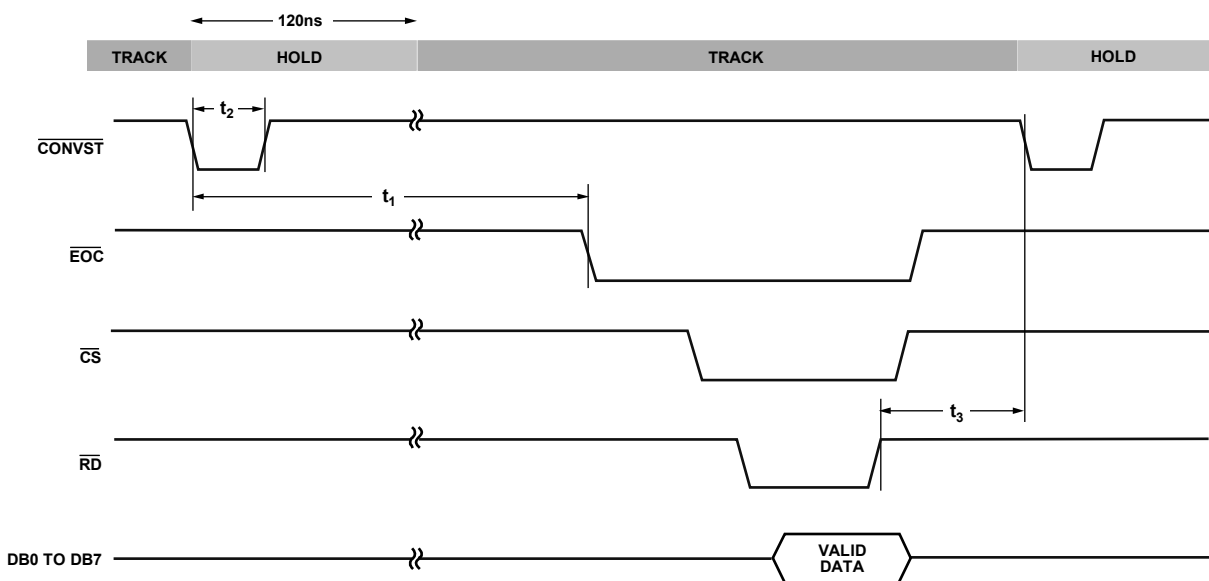

Figure 21. Mode 1 Operation

AD7829-1

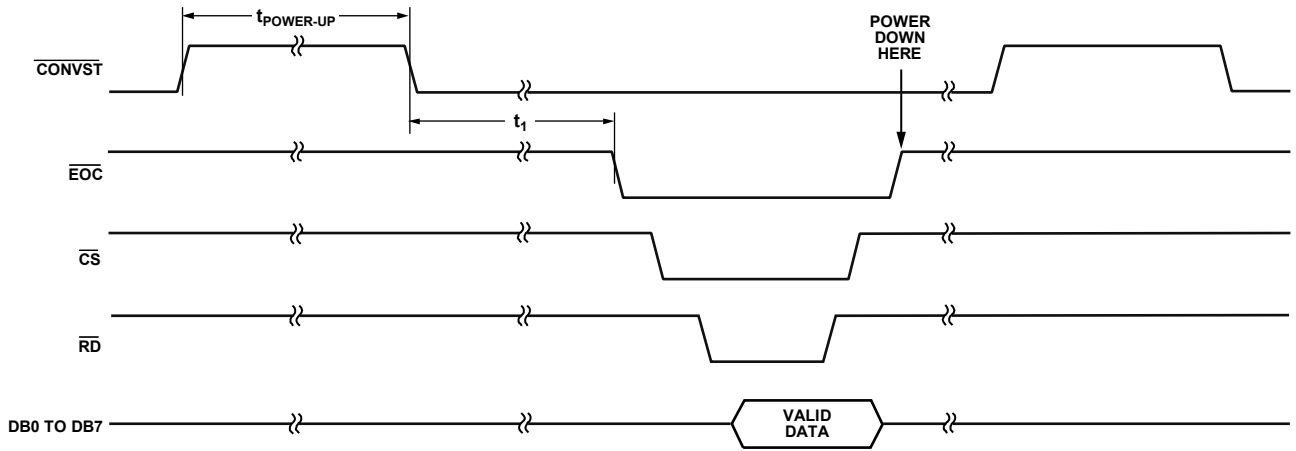

Figure 22. Mode 2 Operation

06179-023

PARALLEL INTERFACE

The parallel interface of the AD7829-1 is eight bits wide. Figure 23 shows a timing diagram illustrating the operational sequence of the AD7829-1 parallel interface. The multiplexer address is latched into the AD7829-1 on the falling edge of the \overline{RD} input. The on-chip track/hold goes into hold mode on the falling edge of \overline{CONVST} . A conversion is also initiated at this point. When the conversion is complete, the end of conversion line (\overline{EOC}) pulses low to indicate that new data is available in the output register of the AD7829-1. The \overline{EOC} pulse stays logic low for a maximum time of 110 ns.

However, the \overline{EOC} pulse can be reset high by a rising edge of \overline{RD} . This \overline{EOC} line can be used to drive an edge-triggered interrupt of a microprocessor. \overline{CS} and \overline{RD} going low accesses the 8-bit conversion result. It is possible to tie \overline{CS} permanently low and use only \overline{RD} to access the data. In systems where the part is interfaced to a gate array or ASIC, this \overline{EOC} pulse can be applied to the \overline{CS} and \overline{RD} inputs to latch data out of the AD7829-1 and into the gate array or ASIC. This means that the gate array or ASIC does not need any conversion status recognition logic, and it also eliminates the logic required in the gate array or ASIC to generate the read signal for the AD7829-1.

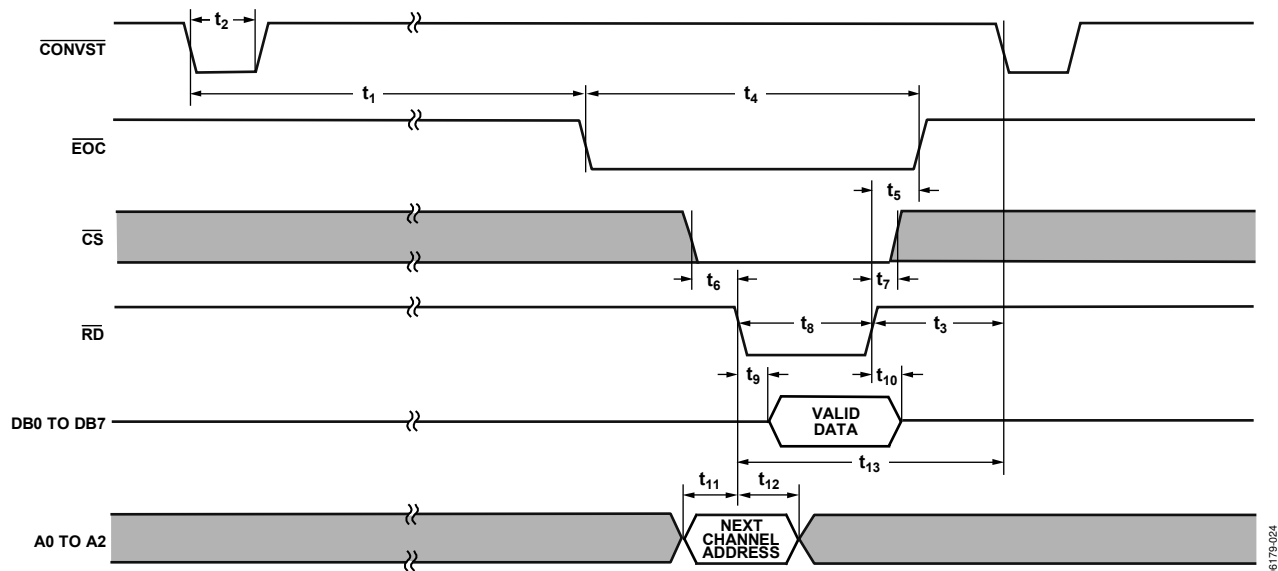

Figure 23. AD7829-1 Parallel Port Timing

06179-024

AD7829-1

MICROPROCESSOR INTERFACING

The parallel port on the AD7829-1 allows the ADCs to be interfaced to a range of many different microcontrollers. This section explains how to interface the AD7829-1 with some of the more common microcontroller parallel interface protocols.

AD7829-1 TO 8051

Figure 24 shows a parallel interface between the AD7829-1 and the 8051 microcontroller. The $\overline{\text{EOC}}$ signal on the AD7829-1 provides an interrupt request to the 8051 when a conversion ends and data is ready. Port 0 of the 8051 can serve as an input or output port, or, as in this case when used together with the address latch enable (ALE) of the AD8051, it can be used as a bidirectional low order address and data bus. The ALE output of the 8051 is used to latch the low byte of the address during accesses to the device, while the high order address byte is supplied from Port 2. Port 2 latches remain stable when the AD7829-1 is addressed, because they do not have to be turned around (set to 1) for data input, as is the case for Port 0.

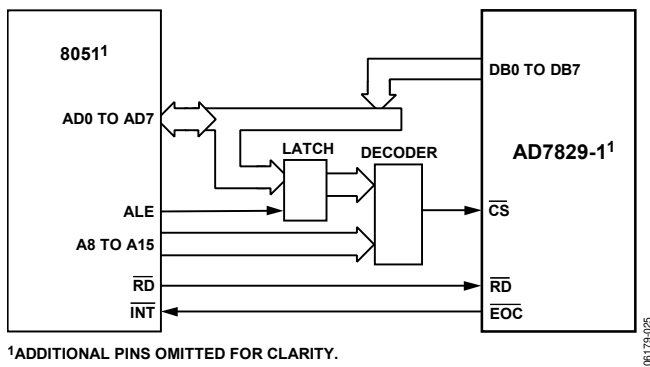
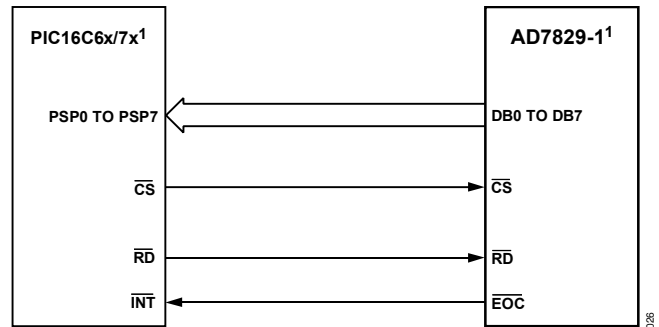

Figure 24. Interfacing to the 8051

AD7829-1 TO PIC16C6x/PIC16C7x

Figure 25 shows a parallel interface between the AD7829-1 and the PIC16C64/PIC16C65/PIC16C74. The $\overline{\text{EOC}}$ signal on the AD7829-1 provides an interrupt request to the microcontroller when a conversion begins. Of the PIC16C6x/PIC16C7x range of microcontrollers, only the PIC16C64/PIC16C65/PIC16C74 can provide the option of a parallel slave port. Port D of the microcontroller operates as an 8-bit wide parallel slave port when Control Bit PSMODE in the TRISE register is set. Setting PSMODE enables Port Pin RE0 to be the RD output and RE2 to be the CS (chip select) output. For this functionality, the corresponding data direction bits of the TRISE register must be configured as outputs (reset to 0). See the PIC16C6x/PIC16C7x Microcontroller User Manual for more information.



ADDITIONAL PINS OMITTED FOR CLARITY.

Figure 25. Interfacing to the PIC16C6x/PIC16C7x

AD7829-1 TO ADSP-21xx

Figure 26 shows a parallel interface between the AD7829-1 and the ADSP-21xx series of DSPs. As before, the $\overline{\text{EOC}}$ signal on the AD7829-1 provides an interrupt request to the DSP when a conversion ends.

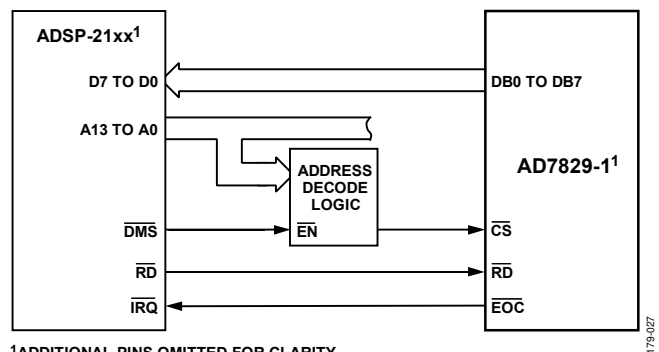

ADDITIONAL PINS OMITTED FOR CLARITY.

Figure 26. Interfacing to the ADSP-21xx

INTERFACING MULTIPLEXER ADDRESS INPUTS

Figure 27 shows a simplified interfacing scheme between the AD7829-1 and any microprocessor or microcontroller that facilitates easy channel selection on the ADCs. The multiplexer address is latched on the falling edge of the RD signal, as outlined in the Parallel Interface section, which allows the use of the three LSBs of the address bus to select the channel address. As shown in Figure 27, only Address Bit A3 to Address Bit A15 are address decoded, allowing A0 to A2 to be changed according to desired channel selection without affecting chip selection.

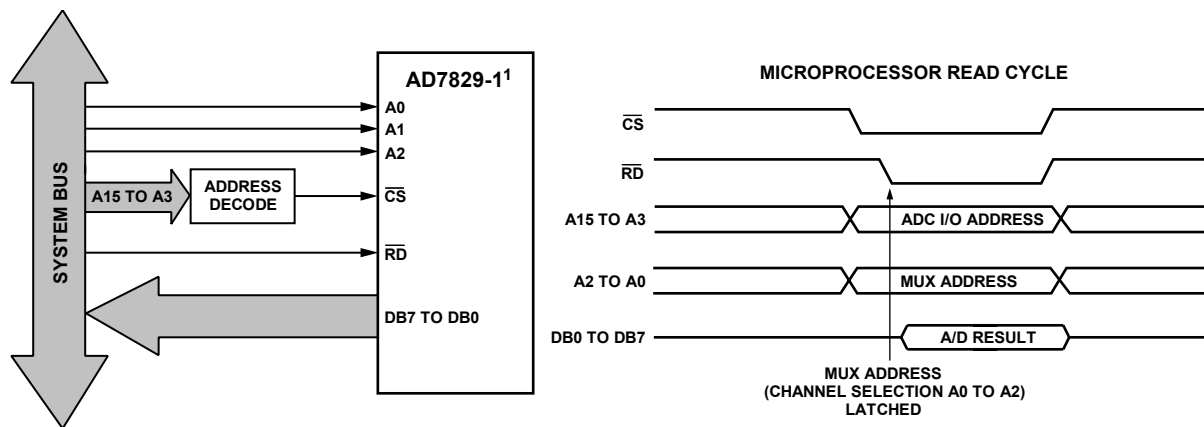
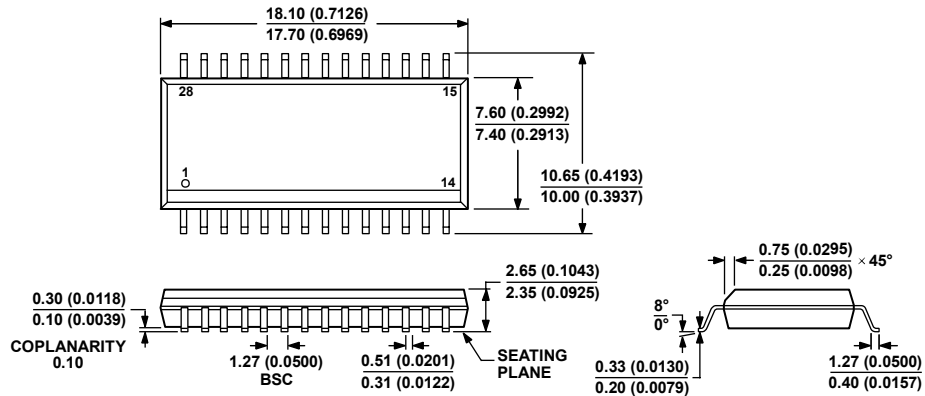

Figure 27. AD7829-1 Simplified Microinterfacing Scheme

06179-028

OUTLINE DIMENSIONS



COMPLIANT TO JEDEC STANDARDS MS-013-AE
CONTROLLING DIMENSIONS ARE IN MILLIMETERS; INCH DIMENSIONS
(IN PARENTHESES) ARE ROUNDED-OFF MILLIMETER EQUIVALENTS FOR
REFERENCE ONLY AND ARE NOT APPROPRIATE FOR USE IN DESIGN.

Figure 28. 28-Lead Standard Small Outline Package [SOIC_W]
Wide Body
(RW-28)
Dimensions shown in millimeters and (inches)

060706-A

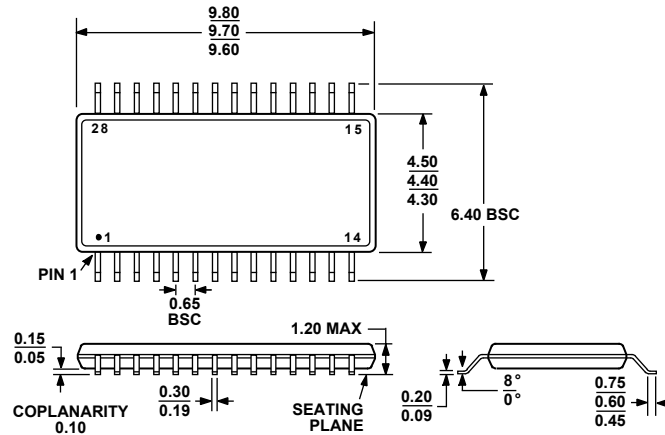

COMPLIANT TO JEDEC STANDARDS MO-153-AE

Figure 29. 28-Lead Thin Shrink Small Outline Package [TSSOP]
(RU-28)
Dimensions shown in millimeters

ORDERING GUIDE

Model	Temperature Range	Package Description	Package Option	Linearity Error
AD7829BRU-1	-40°C to +85°C	28-Lead Thin Shrink Small Outline Package [TSSOP]	RU-28	±0.75 LSB
AD7829BRU-1REEL7	-40°C to +85°C	28-Lead Thin Shrink Small Outline Package [TSSOP]	RU-28	±0.75 LSB
AD7829BRUZ-1 ¹	-40°C to +85°C	28-Lead Thin Shrink Small Outline Package [TSSOP]	RU-28	±0.75 LSB
AD7829BRUZ-1REEL7 ¹	-40°C to +85°C	28-Lead Thin Shrink Small Outline Package [TSSOP]	RU-28	±0.75 LSB
AD7829BRW-1	-40°C to +85°C	28-Lead Standard Small Outline Package [SOIC_W]	RW-28	±0.75 LSB
AD7829BRW-1RL7	-40°C to +85°C	28-Lead Standard Small Outline Package [SOIC_W]	RW-28	±0.75 LSB
AD7829BRWZ-1 ¹	-40°C to +85°C	28-Lead Standard Small Outline Package [SOIC_W]	RW-28	±0.75 LSB
AD7829BRWZ-1RL7 ¹	-40°C to +85°C	28-Lead Standard Small Outline Package [SOIC_W]	RW-28	±0.75 LSB

¹ Z = Pb-free part.