

cannon

MDSM/RTG88
MICROMINIATURE
C O N N E C T O R S

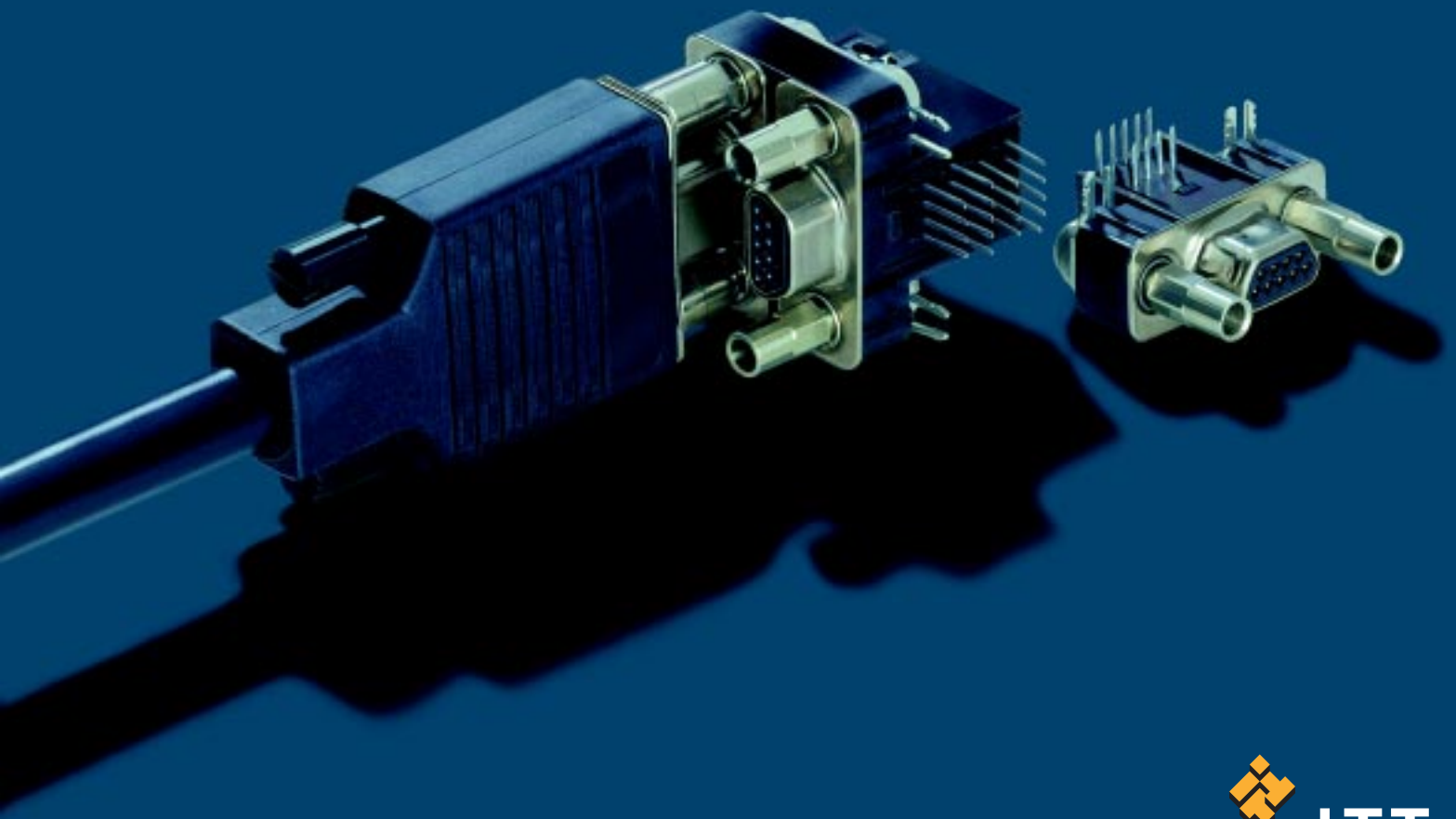

Contents

MICRO MDSM	
Shielded connectors	3
Doubledecker.....	6
Contacts	8
Locking devices.....	9
MDSM with straight solder pins	10
MDSM with crimp contacts, for panel mounting.....	12
Cables.....	14
Tools	14
Product Safety Information.....	15

RoHS Compliance Information

ITT has implemented a strict parts control plan for all ITT electronics plants worldwide that allows the Cannon, VEAM and BIW Connector Systems product portfolios to meet the requirements of European Union Directive 2002/95/EC better known as the Reduction of Hazardous Substances initiative. As appropriate, specific Cannon, VEAM and BIW Connector System products may be ordered with an R prefix number which insures our customers will receive RoHS compliant parts for their commercial electronics applications and equipment. Since most RoHS hazardous substances center around specific metal plating and lead solder coatings, ITT's products for RoHS compliance are available in the following plating finishes: electroless nickel, stainless steel, Anodize over aluminum and gold plating. It should be noted that gold plating would be recommended as the replacement for tin-lead solder when ordering board mount connectors.



MICRO MDSM

Shielded Connectors

MICRO MDSM is the Cannon designation for a shielded interface connector in its Microminiature series. It is ideally suited for applications with specific requirements to the shielding, e.g. components for telecommunications and computers.

The MDSM connector is suitable for modern solder methods, e.g. IR reflow and vapor phase soldering. It is available with crimp contacts (sockets only) as a cable connecting receptacle. Or with 90° solder pins as a pcb connector. The contacts are spaced at 1.27 mm, the solder pins at 1.27 x 2.54 mm. Different locking devices are available – see page 9.

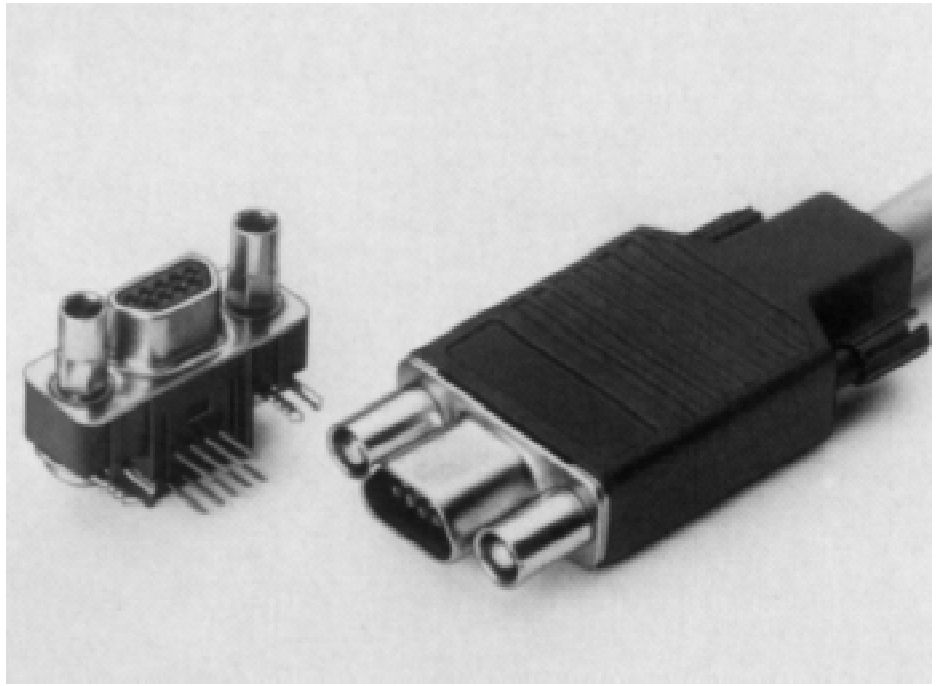

Technical Data

Insulator	Thermoplast, UL94V-0
Contact guiding plate	PA, high temperature resistant
Shell	Steel, tinned and nickel plated
Contacts	Copper alloy
Contact finish	Gold over PdNi
Contact termination area	Tin (SnPb)
Wire size	AWG 28 – 26
Insulation dia.	0.95 mm max
Contact spacing	1.27 mm
Contact number	9, 15, 25
Temperature range acc. DIN IEC 68 Part 1	-55 / 125°C

Electrical Data

Current rating	2.5 A / 25°C
Test voltage	350 Vrms
Contact resistance	20 mΩ max (crimp version) 35 mΩ max (pcb version)
Insulation resistance	5000 MΩ min

Shielding Effectiveness

Frequency MHz	Attenuation dB
10	56
30	47
159	34
500	26
750	22
1000	19

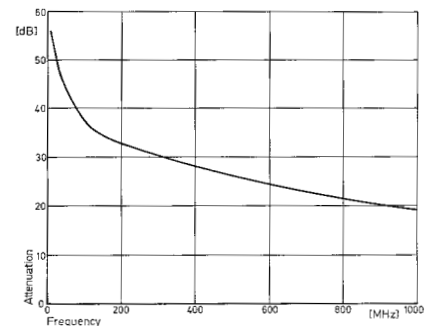

Order Reference

MDSM - 9 P E - Z7 - VR - *

Series _____

Number of contacts _____

9, 15, 25

Contact type _____

P - Pin

S - Socket (with crimp termination only)

Termination method _____

C - Crimp termination (contacts to be ordered separately)

E - Solder pin 90°, spacing 1,27 x 2,54 mm, with rivet nut and grounding tab
(Pin connector only)

Mounting method _____

Z7 - Locking screw ¹⁾

Z10 - Screw for wall thickness 1,5 mm ¹⁾

Z11 - Screw, long, blank ²⁾

Z12 - Screw for wall thickness 1,0 mm ¹⁾

Z24 - Push pull ²⁾

Z33 - Locking screw, short ¹⁾

Z34 - Screw, short, for wall thickness 1,5 mm ¹⁾

Z35 - Screw, short, for wall thickness 1,0 mm ¹⁾

Z41 - Locking screw ¹⁾

Z42 - Screw, for wall thickness 1,5 mm ¹⁾

Z43 - Screw, for wall thickness 1,0 mm ¹⁾

Packaging _____

VR - Tube packaging (not for termination method C)

VS1 - 100 pieces

Modification _____

Please consult factory

¹⁾ for pin connectors only

²⁾ for socket connectors only (cable connecting receptacle)

Tube packaging (VR)

A tube contains the following numbers of MDSM connectors:

No. of contacts	No. of connectors
9	25
15	22
25	17

Ordering MDSM connectors

Tube loaded connectors can only be supplied in the quantity per tube shown above or in multiples thereof. Other quantities cannot be supplied. This also applies when ordering VS1.

MICRO MDSM

Cable Connector

Socket contacts see page 8

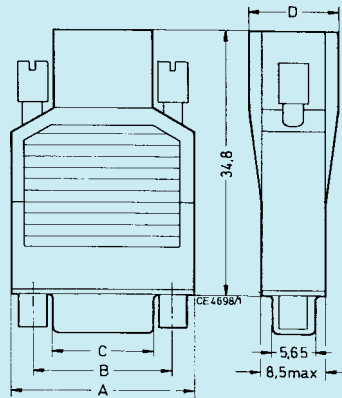

No of contacts	Designation	Dimensions			
		A max	B ± 0,1	C ± 0,1	D ± 0,2
9	MDSM-9SC-Z11-VS1 MDSM-9SC-Z24-VS1	19,9	14,35	9,45	8
15	MDSM-15SC-Z11-VS1 MDSM-15SC-Z24-VS1	23,7	18,16	13,25	8
25	MDSM-25SC-Z11-VS1 MDSM-25SC-Z24-VS1	30,05	24,5	19,6	8

PCB Connector 90°

with pin contacts

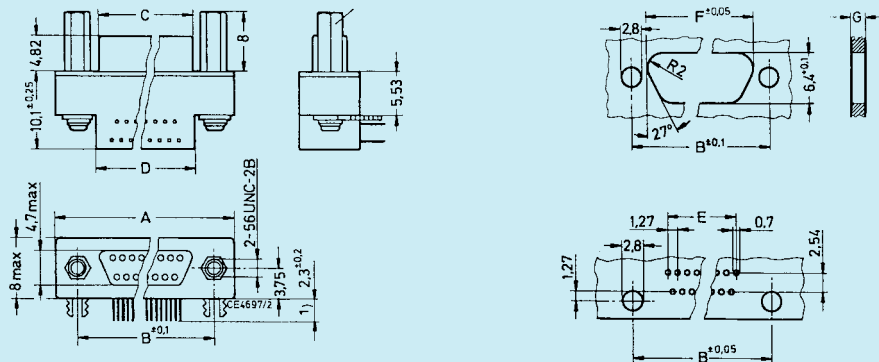

No of contacts	Designation	Dimensions								
		A max	B	C max	D max	E	F	G (wall thickness)		
								-Z7	-Z10	-Z12
9	MDSM-9PE-Z* -VR25	19,9	14,35	8,6	9,0	5,08	10,24	0,00	1,5	1,0
15	MDSM-15PE-Z* -VR22	23,7	18,16	12,4	12,8	8,89	14,00	0,00	1,5	1,0
25	MDSM-25PE-Z* -VR17	30,05	24,5	18,8	19,15	15,24	20,35	0,00	1,5	1,0

* indicate mounting method

Doubledecker

This connector version offers higher packaging density. The MDSM Doubledecker provides twice the number of contacts in only 30% extra space.

Two Standard MDSM cable connectors with the corresponding number of contacts mate with the MDSM Doubledecker. The MDSM Doubledecker is available with pin contacts only.

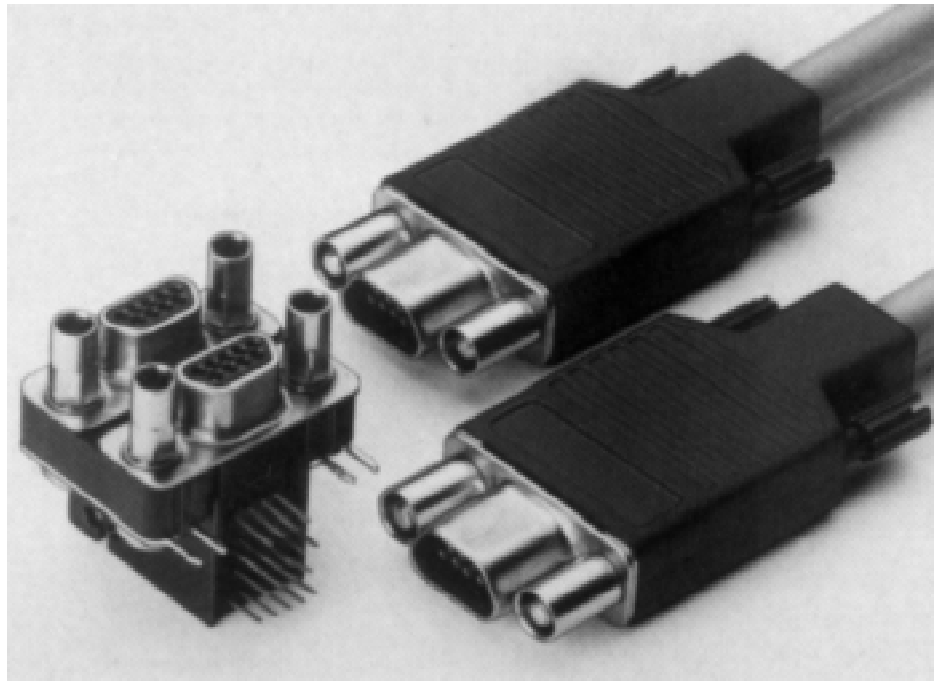

Technical Data

Insulator	Thermoplast, UL94V-0
Contact guiding plate	PA, high temperature resistant
Shell	Steel, tinned and nickel plated
Contacts	Copper alloy
Contact finish	Gold over PdNi
Contact termination area	tinned (SnPb)
Contact spacing	1.27 mm
Contact number	18, 30
Temperature range acc. DIN IEC 68 Part 1	-55 / 125°C

Electrical Data

Current rating	2.5 A / 25°C (row 1, 2) 1.8 A / 25°C (row 3, 4)
Test voltage	350 Vrms
Contact resistance	35 mΩ max (row 1, 2) 55 mΩ max. (row 3, 4)
Insulation resistance	5000 MΩ min

Doubledecker

Order Reference

MDSM - 18 P E - Z7 - VR

Series _____

Number of contacts _____
18, 30

Contact type _____
P - Pin

Termination method _____
E - Solder pin 90°, spacing 1,27 x 2,54 mm
with rivet nut and grounding tab

Mounting method* _____
Z7 - Locking screw
Z10 - Screw for wall thickness 1,5 mm
Z12 - Screw for wall thickness 1,0 mm
* Additional mounting methods on page 9

Packaging _____
VR - Tube packaging (not for termination method C)

Tube packaging (VR)

A tube contains the following numbers of MDSM connectors:

No. of contacts	No. of connectors
18	25
30	22

Ordering MDSM connectors

Tube loaded connectors can only be supplied in the quantity per tube shown in the table or in multiples thereof. Other quantities cannot be supplied.

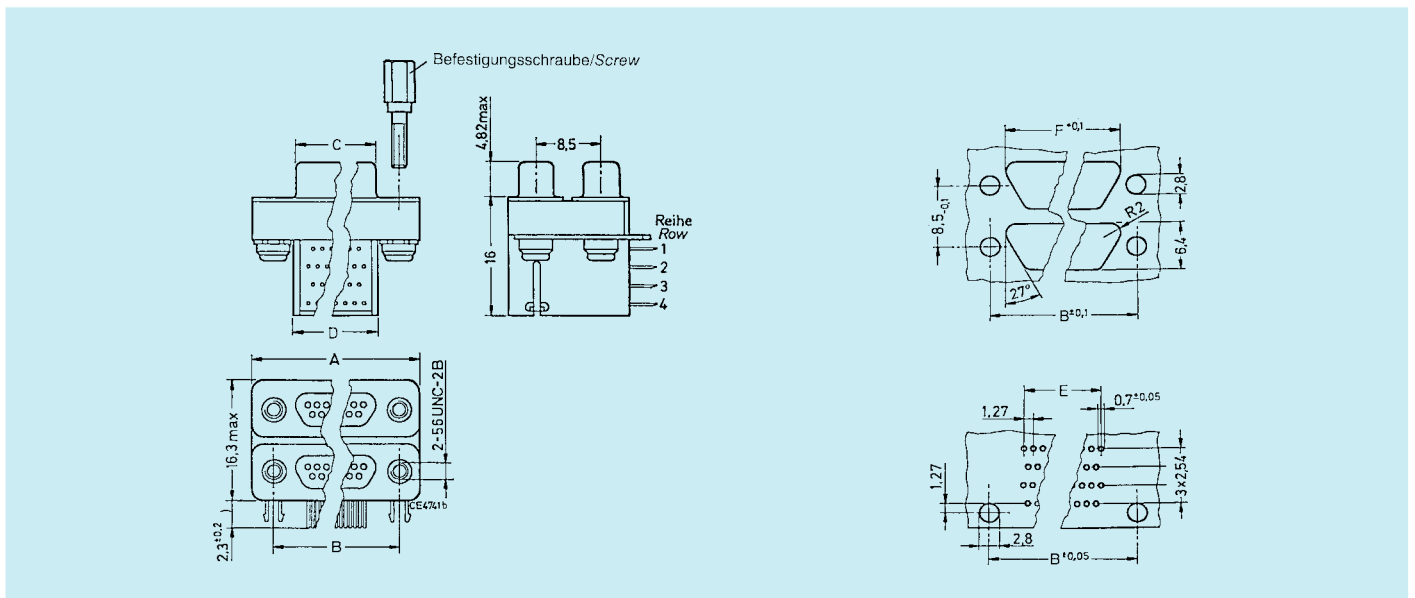

No of contacts	Designation	Dimensions								
		A max	B	C max	D max	E	F	G (Wall thickness)		
								-Z7	-Z10	-Z12
18	MDSM-18PE-Z* -VR25	19,9	14,35	8,6	9,0	5,08	10,24	0,00	1,5	1,0
30	MDSM-30PE-Z* -VR22	23,7	18,16	12,4	12,8	8,89	14,00	0,00	1,5	1,0

* indicate mounting method

MICRO MDS/MDSM

Signal Contacts

on reels / 1000 pieces (TS)

MDS-P-TS	Pin contact
MDS-S-TS	Socket contact

on reels / 10 000 pieces (RL)

MDS-P-RL	Pin contact
MDS-S-RL	Socket contact

The contacts (1.2 mm PdNi with 0.1 μm Au over 0.5 μm Ni) are tin plated in the crimp area.
Wire size AWG 28 – 26 (0.09 – 0.14 mm²).

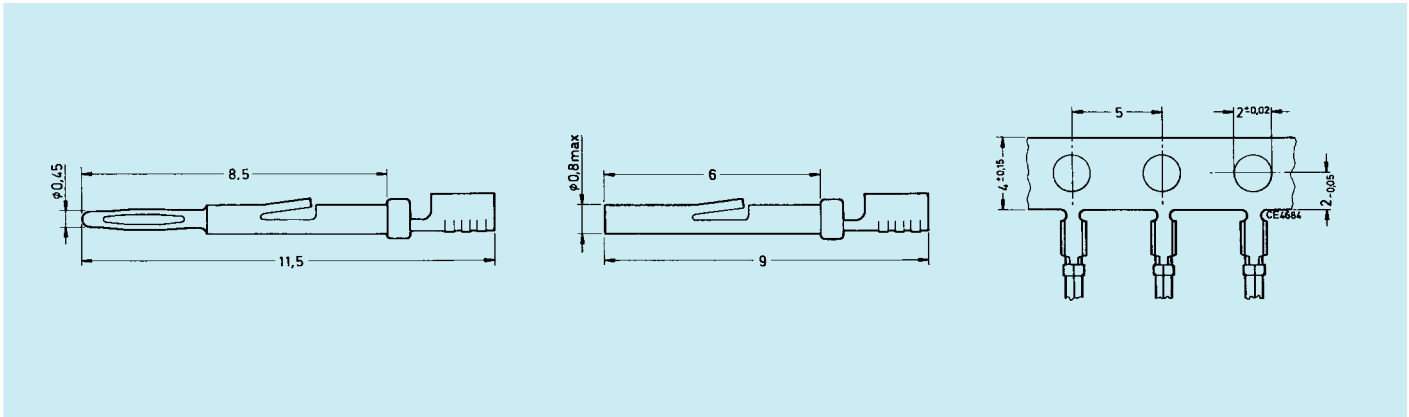

MICRO MDSM

Screw locking

for cable connectors (socket side)

Z11 Screw, long, blank

for pcb connectors (pin side)

Z7 Locking screw

Z10 Screw for wall thickness 1.5 mm

Z12 Screw for wall thickness 1 mm

Z33 Locking screw, short

Z34 Screw, short, for wall thickness 1.5 mm

Z35 Screw, short, for wall thickness 1 mm

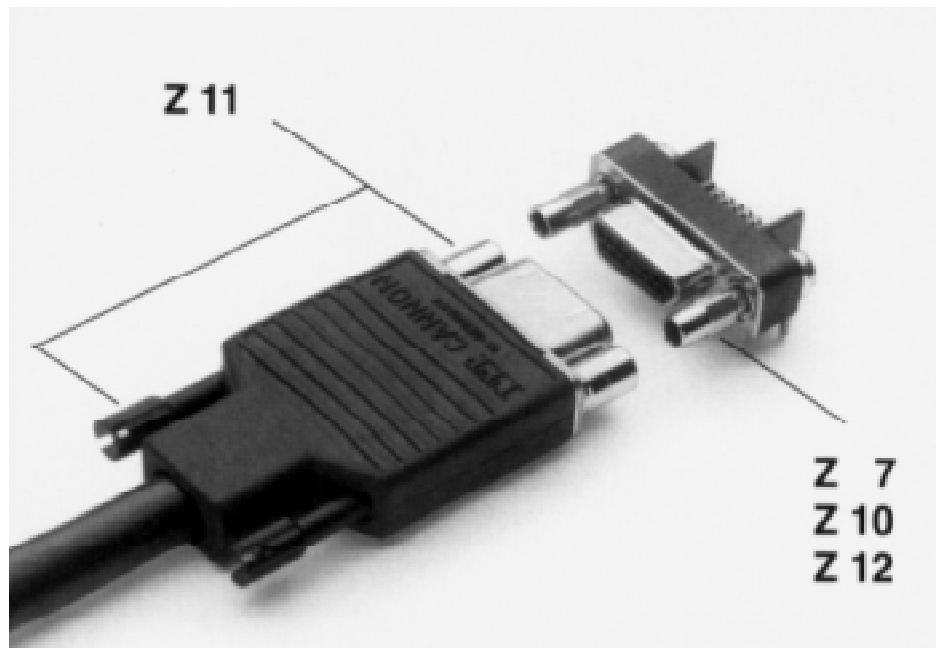

Push Pull

for cable connectors (socket side)

Z24 Push pull

for pcb connectors (pin side)

Z41 Locking pin

Z42 Screw, for wall thickness 1.5 mm

Z43 Screw, for wall thickness 1 mm

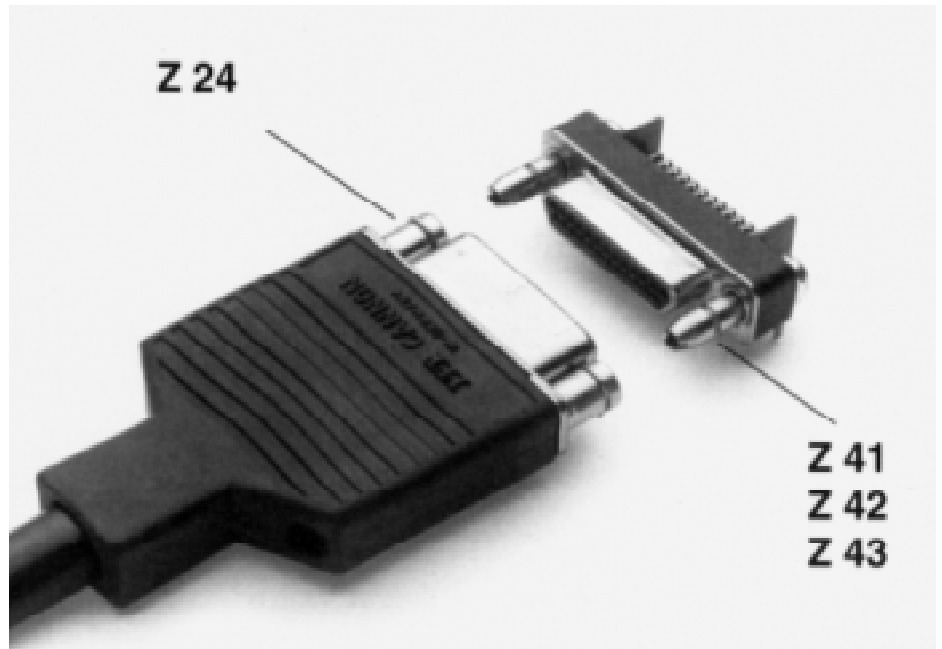

MICRO MDSM

with straight solder pins

Due to customer requirements connectors MDSM-9PE-Z** with 90° termination are not suitable for all applications. There is great interest for a MDSM version with straight terminations. To fulfill market requirements the following connector versions and tools were developed:

MDSM-9PA-Z7/Z10 and MDSM-9PA-Z41/Z42 with straight terminations and pcb locking.

Typical Applications

SSA band and disk drives, SSA distribution panels, bar code readers, mobile telecommunications and medical equipment.

Locking of PC Board

The mating and unmating forces are concentrated on to an integrated PCB locking, after the connector has been mounted on a pc board.

Please note:

The standard screw locking which is being used for MDSM-9PE-Z10 do **not** apply to MDSMA-9PA.

The MDSM-9PA screws require a shorter thread.

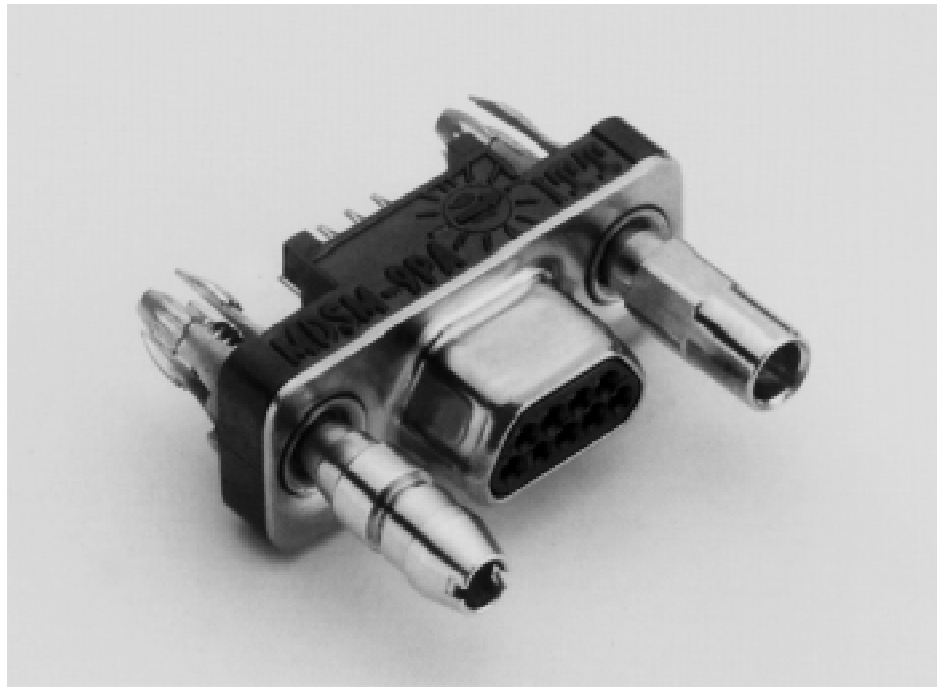

MDSM-9PA Connector optionally with push-pull or screw locking

Technical Data

Insulator	Thermoplast, UL 94V-0
Shell	Steel, tinned and nickel plated
Contacts	Copper alloy
Contact finish	Gold over PdNi
Contact termination	tinned
Wire size	AWG 28 – 26
Contact spacing	1,27 mm
Contact number	9
Temperature range acc to DIN IEC 68 part 1	-55 / 125°C

Electrical Data

Current rating	1,5 A / 55°C
Voltage rating	350 Vrms
Contact resistance	20 mΩ max
Insulation resistance	5000 MΩ

Dimensions

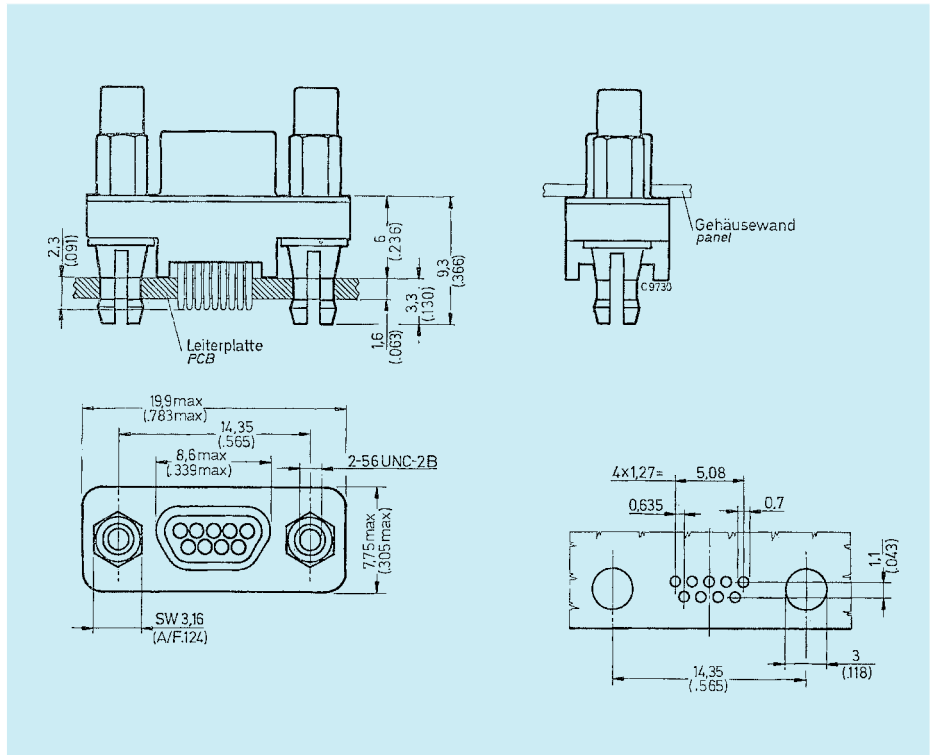

Mounting Methods

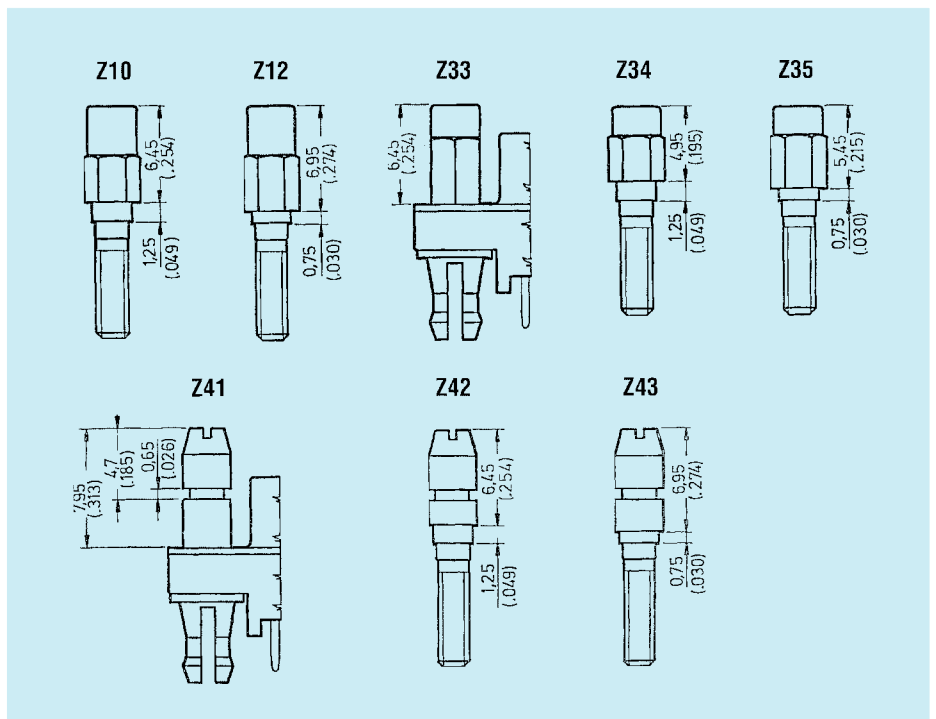

MICRO MDSM

with crimp contacts, for panel mounting

The market shows great interest for a MDSM Inline receptacle with pin contacts for crimp termination. To fulfill this requirements the following connector versions and tools have been developed to accomodate pin contacts crimped to wire sizes AWG 28 – 26:

- MDSM-9PC-Z7/Z10-O- VS1
- MDSM-9PC-Z42-O-VS1

Contacts

Contacts MDS-P-TS (1000 contacts / reel) or MDS-P-RL (10.000 contacts / reel) to be ordered separately.

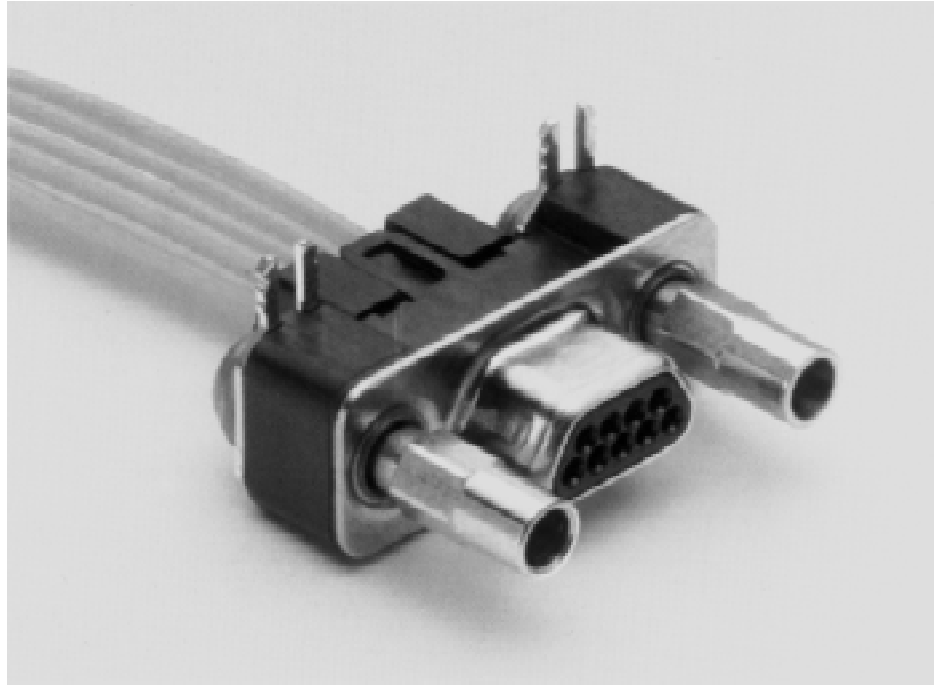

MDSM-9PC Connector with screw locking

Technical Data

Insulator	Thermoplast, UL 94V-0
Shell	Steel, tinned and nickel plated
Contacts	Copper alloy
Contact finish	Gold over PdNi
Contact termination	tinned
Wire size	AWG 28 – 26
Contact spacing	1,27 mm
Contact number	9
Temperature range acc to DIN IEC 68 part 1	-55 / 125°C

Electrical Data

Current rating	2,0 A / 55°C
Voltage rating	350 Veff
Contact resistance	20 mΩ max
Insulation resistance	5000 MΩ

MICRO MDSM

Dimensions

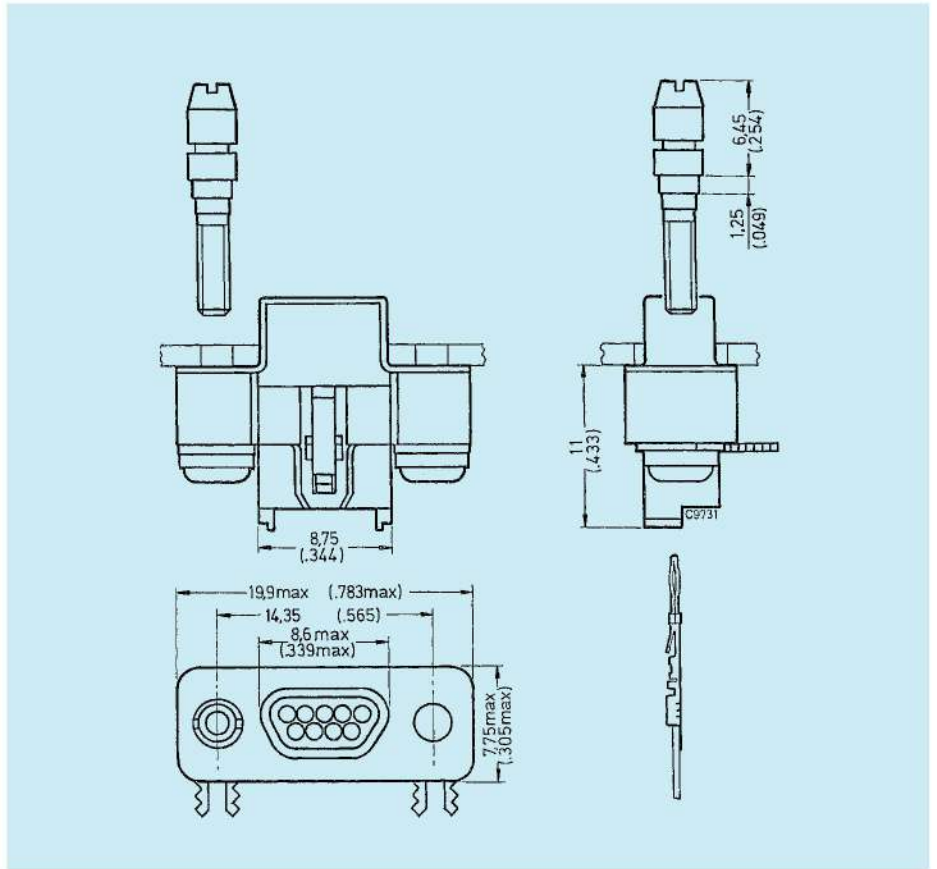

Panel Cutout

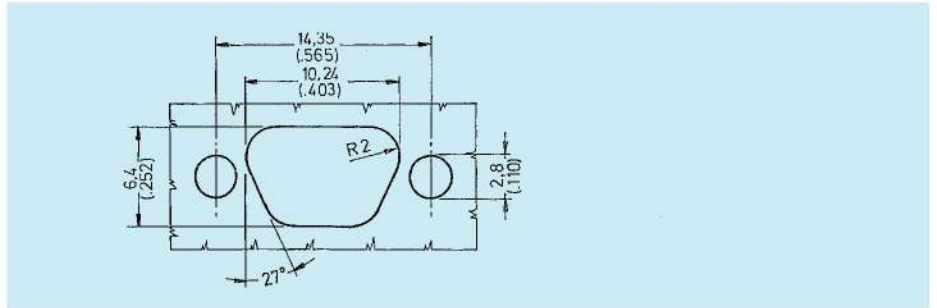

MDSM**Stranded wire**

Conductors	Copper, tinned AWG 26 / 7 x 0,160 mm AWG 28 / 7 x 0,127 mm
Insulation	PVC, PP or HDPE, Outer dia. max. 0,9 mm
Wall thickness	AWG 26: generally min. 0,140 mm AWG 28: generally min. 0,152 mm for all: min. permissible thickness at any position .127 mm

Cable

Shielding	Shielding braid, tinned copper, coverage min. 80%								
Insulation	PVC								
Wall thickness	0.56 mm min. at any position* 0.76 mm min. at any position**								
Outer diameter	<table> <thead> <tr> <th>Strands</th> <th>Outer diameter mm max.</th> </tr> </thead> <tbody> <tr> <td>9</td> <td>5,7</td> </tr> <tr> <td>15</td> <td>6,7</td> </tr> <tr> <td>25</td> <td>7,9</td> </tr> </tbody> </table>	Strands	Outer diameter mm max.	9	5,7	15	6,7	25	7,9
Strands	Outer diameter mm max.								
9	5,7								
15	6,7								
25	7,9								
Temperature range	-40 / 80°C								
Operating voltage	300 Vrms								
Test voltage	1000 Vrms min.								
Conductor resistance	240 Ω/km								

* Cable with 9 wires or 5 twisted pairs

** Cable with more than 9 wires or more than 5 twisted pairs

Tooling

Hand crimp tool (for reeled contacts)	CCTR-MDS
Semi-automatic stripper / crimper	EPS 3500-MDS
Insertion tool	CT 120090-102
Other tools	see assembly instruction

THIS NOTE SHOULD BE READ IN CONJUNCTION WITH THE PRODUCT DATA SHEET/CATALOGUE. FAILURE TO OBSERVE THE ADVICE IN THIS INFORMATION SHEET AND THE OPERATING CONDITIONS SPECIFIED IN THE PRODUCT DATA SHEET/CATALOGUE COULD RESULT IN HAZARDOUS SITUATIONS.

1. MATERIAL CONTENT AND PHYSICAL FORM

Electrical connectors do not usually contain hazardous materials. They contain conducting and non-conducting materials and can be divided into two groups.

a) Printed circuit types and low cost audio types which employ all plastic insulators and casings.

b) Rugged, Fire Barrier and High Reliability types with metal casings and either natural rubber, synthetic rubber, plastic or glass insulating materials.

Contact materials vary with type of connector and also application and are usually manufactured from either copper, copper alloys, nickel, alumel, chromel or steel. In special applications, other alloys may be specified.

2. FIRE CHARACTERISTICS AND ELECTRIC SHOCK HAZARD

There is no fire hazard when the connector is correctly wired and used within the specified parameters. Incorrect wiring or assembly of the connector or careless use of metal tools or conductive fluids, or transit damage to any of the component parts may cause electric shock or burns. Live circuits must not be broken by separating mated connectors as this may cause arcing, ionisation and burning.

Heat dissipation is greater at maximum resistance in a circuit. Hot spots may occur when resistance is raised locally by damage, e.g. cracked or deformed contacts, broken strands of wire. Local overheating may also result from the use of the incorrect application tools or from poor quality soldering or slack screw terminals. Overheating may occur if the ratings in the Product Data Sheet/Catalogue are exceeded and can cause breakdown of insulation and hence electric shock.

If heating is allowed to continue it intensifies by further increasing the local resistance through loss of temper of spring contacts, formation of oxide film on contacts and wires, and leakage currents through carbonisation of insulation and tracking paths. Fire can then result in the presence of combustible materials and this may release noxious fumes. Overheating may not be visually apparent. Burns may result from touching overheated components.

3. HANDLING

Care must be taken to avoid damage to any component parts of electrical connectors during installation and use. Although there are normally no sharp edges, care must be taken when handling certain components to avoid injury to fingers.

Electrical connectors may be damaged in transit to the customers, and damage may result in creation of hazards. Products should therefore be examined prior to installation/use and rejected if found to be damaged.

4. DISPOSAL

Incineration of certain materials may release noxious or even toxic fumes.

5. APPLICATION

Connectors with exposed contacts should not be selected for use on the current supply side of an electrical circuit, because an electric shock could result from touching exposed contacts on an unmated connector. Voltages in excess of 30 V ac or 42.5 V dc are potentially hazardous and care should be taken to ensure that such voltages can not be transmitted in any way to exposed metal parts of the connector body. The connector and wiring should be checked, before making live, to have no damage to metal parts or insulators, no solder blobs, loose strands, conducting lubricants, swarf, or any other undesired conducting particles. Insulation resistance should be checked to make certain that no low resistance joints or spurious conducting path are existing between contacts and exposed metal parts of the connector body. Further the contact resistance of the connectors should be measured within the electrical circuit in order to identify high resistances which result in excessive connector heating.

Always use the correct application tools as specified in the Data Sheet/Catalogue.

Do not permit untrained personnel to wire, assemble or tramper with connectors.

For operation voltage please see appropriate national regulations.

IMPORTANT GENERAL INFORMATION.

1. Air and creepage paths/Operating voltage

The admissible operating voltages depend on the individual applications and the valid national and other applicable safety regulations.

For this reason the air and creepage path data are only reference values. Observe reduction of air and creepage paths due to PCboard and/or harnessing.

2. Temperature

All information given are temperature limits. The operation temperature depends on the individual application.

3. Other important information

Cannon continuously endeavours to improve their products. Therefore, Cannon products may deviate from the description, technical data and shape as shown in this catalogue and data sheets.

4. Harnessing and Assembly Instructions

If applicable, our special harnessing and/or assembly instruction has to be adhered to. This is provided at request.

ITT Cannon manufactures the highest quality products available in the marketplace; however these products are intended to be used in accordance with the specifications in this catalog. Any use or application that deviates from stated operating specifications is not recommended and may be unsafe. No information and data contained in this catalog shall be construed to create any liability on the part of Cannon. Any new issue of this catalog shall automatically invalidate and supersede any and all previous issues. **A limited warranty applies to Cannon products. Except for obligations assumed by Cannon under this warranty, Cannon shall not be liable for any loss, damage, cost of repairs, incidental or consequential damages of any kind, whether or not based on express or implied warranty, contract, negligence or strict liability arising in connection with the design, manufacture, sale, use or repair of the products.** Product availability, prices and delivery dates are exclusively subject to our respective order confirmation form; the same applies to orders based on development samples delivered. This catalog is not be construed as an offer. It is intended merely as an invitation to make an offer. By this publication, Cannon does not assume responsibility or any liability for any patent infringements or other rights of third parties which may result from its use. Reprinting this catalog is generally permitted, indicating the source. However, Cannon's prior consent must be obtained in all cases.

Cannon is a trademark of ITT Industries, Inc

Cannon Worldwide Facilities

Austria

Afrikanergasse 3
1020 Vienna
FAX: (1) 2160948 PH: (1) 2160947

Benelux

Rue Col. Bourg Str. 105A
1140 Brussels, Belgium
FAX: (02) 7269201 PH: (02) 726 75 94
NL
FAX: 31.35.691.8796 PH: 31.35.691.6855

China

No. 24, 2 Block
Taohuawu New District
Zhenjiang, Jiangsu
P.R.C.
FAX: 86 511 4428616 PH: 86 511 443 3399

Denmark

Park Allé 287 A
2605 Brøndby
FAX: 43 43 58 58 PH: 43 45 52 88

Finland

Virkatie 1
1510 Vantaa
FAX:+358 9 70039188 PH: +358 9 70039180

France

2, Ave Sablons Bouillants, B.P. 133
77109 Meaux
FAX: (1) 64 33 16 82 PH: (1) 60 24 51 51

Germany

Postfach 11 20, 71365 Weinstadt
Cannonstrasse 1, 71384 Weinstadt
FAX: (07151) 699217 PH: (07151) 699-0

Hong Kong

906 New World Office Building
West Wing, 20 Salisbury Road
Tsim Sha Tsui, Kowloon
FAX: (852) 2369-5651 PH: (852) 2732-2720

Italy

Via Panzeri 10
20123 Milano
FAX: (02) 8372036 PH: (02) 581801

Japan

5362-1, 5-chome, Hibarigaoka
Zama-shi, Kanagawa 228
FAX: 0462-57-1680 PH: 0462-57-2010

Korea

620, Changkang Bldg.
#22, Dohwa-dong, Mapo-ku
Seoul
FAX: (02) 717 7330 PH: (02) 702 7111

Spain

Edificio Italia 1a planta
Parque Empresarial San Fernando
San Fernando de Henares
28831 Madrid
FAX: (34) 91 656 15 83 PH: (34) 91 656 03 11

Sweden

Norr Mälarstrand 64
Jaktvarvet 1
11235 Stockholm
FAX: (46) 8 650 0072 PH: (46) 8 650 0071

Switzerland

Herzogenmühle 18
8304 Wallisellen
FAX: (01) 830-3104 PH: (01) 830-3888, 830-3613

United Kingdom

Jays Close, Viabes Estate
Basingstoke Hampshire RG22 4BA
FAX: (01256) 323356 PH: (01256) 311200

United States

666 E. Dyer Road
Santa Ana, CA 92705-5612
FAX: 714.628.2142 PH: 714.557.4700

INTERNET

<http://www.ittcannon.com>
