

Approval Sheet

(產品承認書)

產品名稱 (Product)	<u>Bluetooth Low Energy Module</u>
解決方案 (Solution)	<u>Nordic nRF52820 QFN Package</u>
產品型號 (Model No.)	<u>MDBT50 – 256R (Chip Antenna)</u> <u>MDBT50 – P256R (PCB Antenna)</u>
產品料號 (Part No.)	<u>see 4.3 Order Code</u>

1. Working distance of MDBT50 & MDBT50-P in open space:
 - **125 kbps:** up to 500 meters
 - **1 Mbps:** up to 270 meters
 - **2 Mbps:** up to 135 meters
2. Declaration ID includes all Nordic applied profiles.
3. Granted main regional certification such as FCC (USA), CE(EU), TELEC (Japan), SRRC (China), IC (Canada), NCC (Taiwan), and KC (South Korea)

Index

1. Overall Introduction	4
1.1. Application	4
1.2. Features	5
2. Product Dimension	7
2.1. PCB Dimensions & Pin Indication.....	7
2.2. Recommended Layout of Solder Pad	9
2.3. RF Layout Suggestion (aka Keep-Out Area)	13
2.4. Footprint & Design Guide	15
2.5. Pin Assignment.....	16
2.6. GPIO Located Near the Radio.....	17
3. Main Chip Solution.....	18
4. Shipment Packaging Information	19
4.1. Marking on Metal Shield	20
4.2. Packaging Info.....	21
4.3. Order Code.....	23
5. Specification	24
5.1. Absolute Maximum Ratings	24
5.2. Operating Conditions	24
5.3. Electrical Specifications	25
6. Block Diagram	31
7. Antenna	32
7.1. MDBT50	32
7.2. MDBT50-P.....	33
8. Reference Circuit.....	34
8.1. Reg0 LDO Mode.....	35
8.2. Reg0 LDO Mode Disabled.....	37
8.3. USB Powered	39
8.4. USB Disabled	41
9. Certification	43
9.1. Declaration ID	43
9.2. FCC Certificate (USA)	44
9.3. TELEC Certificate (Japan).....	45

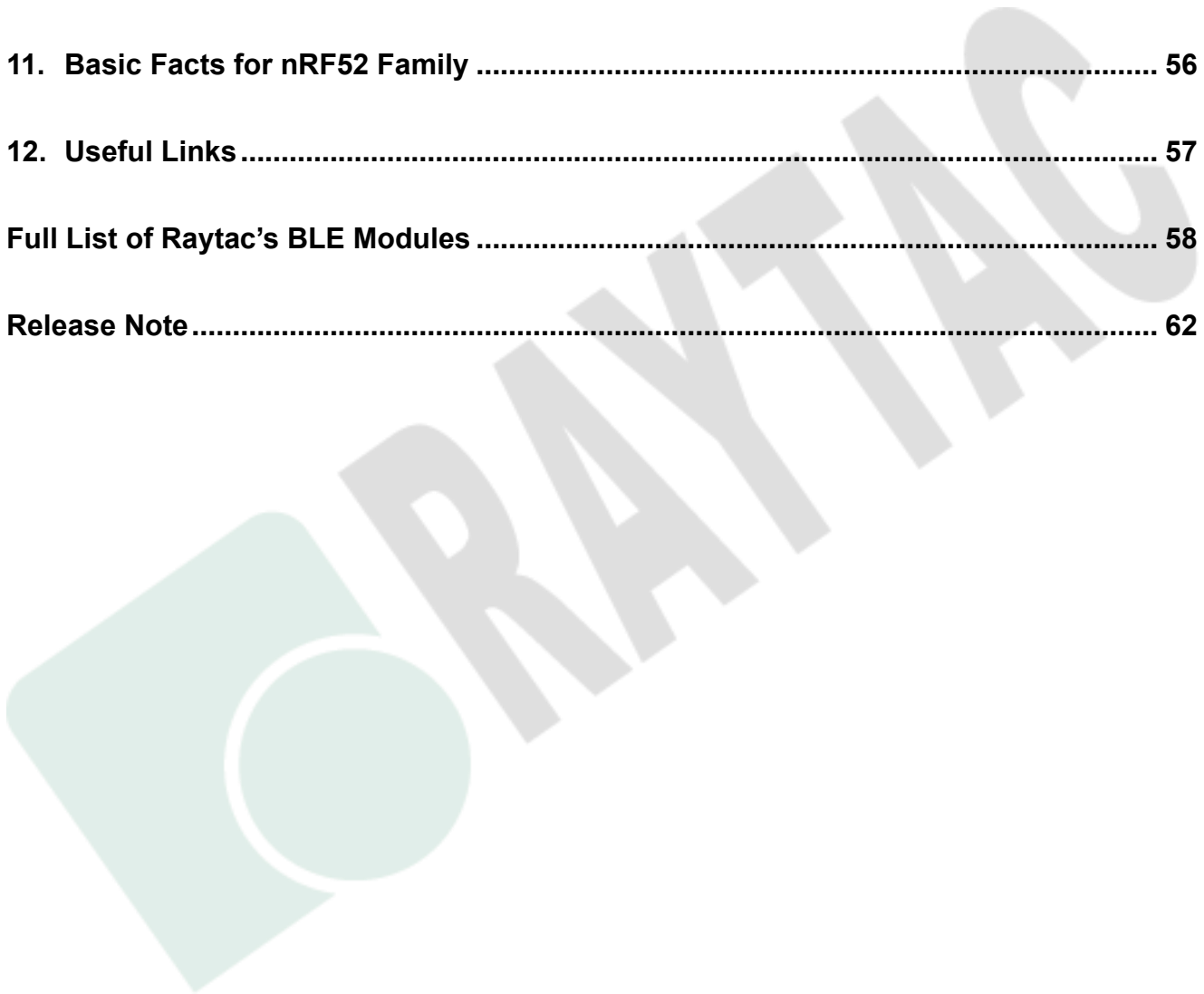

9.4.	NCC Certificate (Taiwan)	46
9.5.	CE (EU) & RCM (Australia & New Zealand) Test Report.....	48
9.6.	IC Certificate (Canada).....	50
9.7.	SRRC Certificate (China).....	51
9.8.	KC Certificate (South Korea)	52
9.9.	RoHS & REACH Report	53
9.10.	End-Product Label.....	53
10.	Notes and Cautions.....	55
11.	Basic Facts for nRF52 Family	56
12.	Useful Links.....	57
	Full List of Raytac’s BLE Modules	58
	Release Note.....	62



1. Overall Introduction

Raytac's MDBT50-256R & MDBT50-P256R is a BT 5.0 & BT 5.1 stack (Bluetooth low energy or BLE) module designed based on **Nordic nRF52820 SoC solution**, which incorporates: **GPIO, SPI, UART, I2C** and **USB** interfaces for connecting peripherals and sensors.

Features:

1. Embedded 2.4GHz transceiver supports Bluetooth 5.1 ( **Bluetooth**®), IEEE 802.15.4 ( **THREAD** & Zigbee) & 2.4Ghz RF & ANT+ upon customer's preference.
2. Compact size with **(L) 13.2 x (W) 8.4 x (H) 2.1 mm**.
3. Low power requirements, ultra-low peak, average and idle mode power consumption.
4. Be compatible with a large installed base of mobile phones, tablets and computers.
5. Fully coverage of BLE software stack.
6. BLE & RF transmission switching helps products fit all operation system and most hardware.

1.1. Application

- IoT Networks
 - Smart home sensors and controllers
 - Industrial IoT sensors and controllers
- Interactive entertainment devices
 - Remote controls
 - Gaming controller
- Advanced computer peripherals and I/O devices
 - Mouse
 - Keyboard
 - Multi-touch trackpad

1.2. Features

- Bluetooth 5.1, IEEE 802.15.4, 2.4 GHz transceiver
 - -95 dBm sensitivity in 1 Mbps Bluetooth low energy (BLE) mode
 - -103 dBm sensitivity in 125 Kbps BLE mode (long range)
 - +8 dBm TX power (down to -20 dBm in 4 dB steps)
 - On-air compatible with nRF52, nRF51, nRF24L and nRF24AP Series
 - Programmable output power from +8dBm to -20dB
 - RSSI (1 dB resolution)
 - Supported data rates:
 - Bluetooth 5.1: 2 Mbps, 1 Mbps, 500 kbps, 125 kbps
 - IEEE 802.15.4-2006: 250 kbps
 - Proprietary 2.4 GHz: 2 Mbps, 1 Mbps
 - Angle-of-arrival (AoA) and angle-of-departure (AoD) direction finding using Bluetooth®.
- ARM Cortex –M4 32-bit processor with 64 MHz
- Memory: 256KB flash / 32KB RAM
- HW accelerated security
 - 128 bit AES / ECB / CCM / AAR co-processor (on-the-fly packet encryption)
- Advanced on-chip interfaces
 - USB 2.0 full speed (12 Mbps) controller
 - 8MHz SPI
 - Programmable peripheral interconnect (PPI)
 - 18 general purpose I/O pins
 - EasyDMA automated data transfer between memory and peripherals
- 4 X 32-bit timers with counter mode
- Up to 2 x SPI masters / 2 x SPI slaves with EasyDMA
- Up to 2 x I2C compatible 2-wire master / slave
- 1 x UART(CTS/RTS) with EasyDMA
- Quadrature decoder (QDEC)
- 2 x real-time counters (RTC)

- Flexible power management
 - Supply voltage range 1.7V to 5.5V
 - On-chip DC/DC and LDO regulators with automated low current modes
 - Automated peripheral power management
 - Fast wake-up using 64MHz internal oscillator
 - 0.3uA at 3V in System OFF mode, no RAM retention
 - 1.2uA at 3V in System ON mode, no RAM retention, wake on RTC
- Nordic SoftDevice ready with support for concurrent multi-protocol
- Operating temperature from -40 to 105 °C

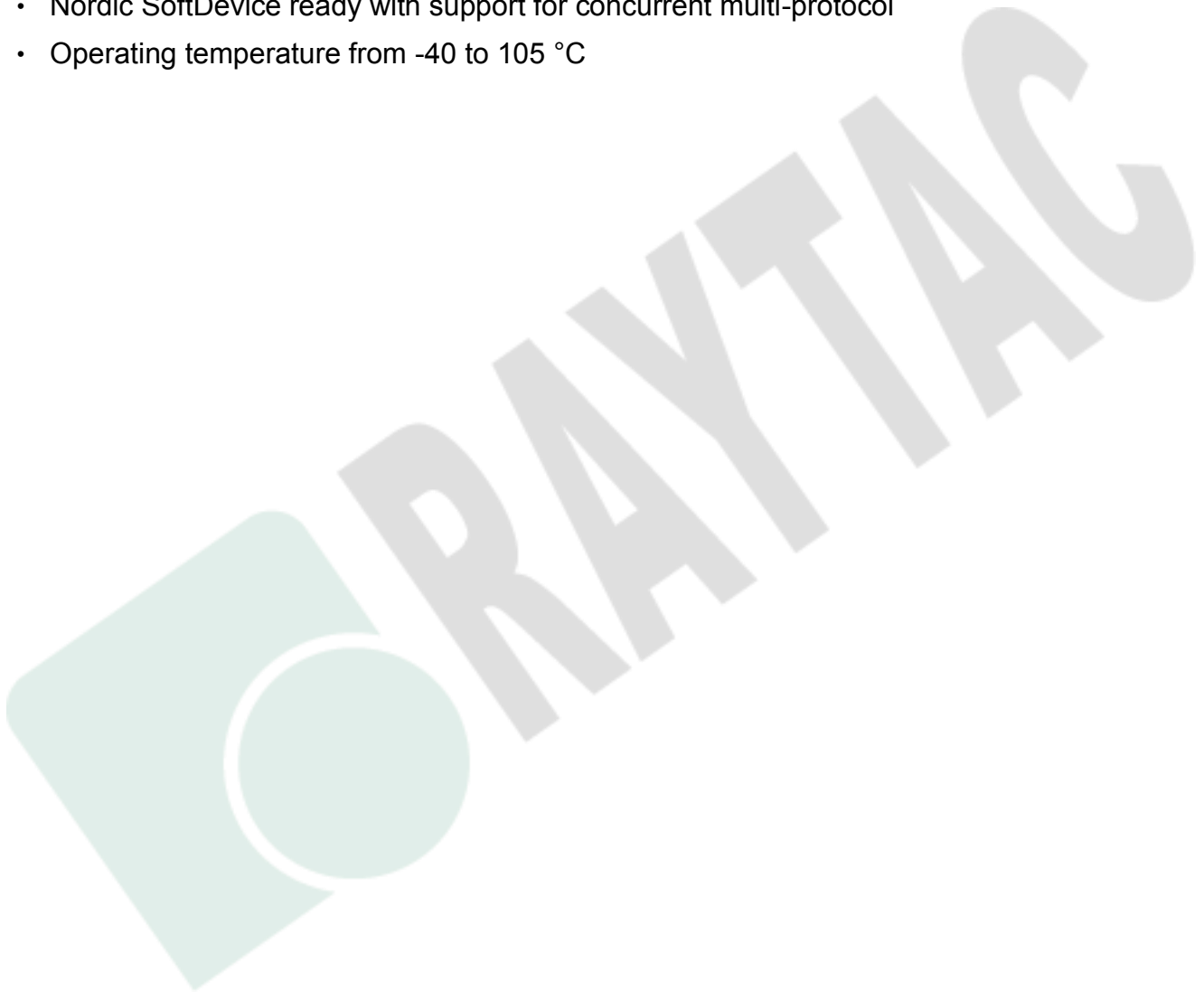

2. Product Dimension

2.1. PCB Dimensions & Pin Indication

- **MDBT50-256R**

PCB Size (in mm)			
	Min.	Norm	MAX.
L		13.2	
W	- 0.15	8.4	+ 0.2
H		2.1	

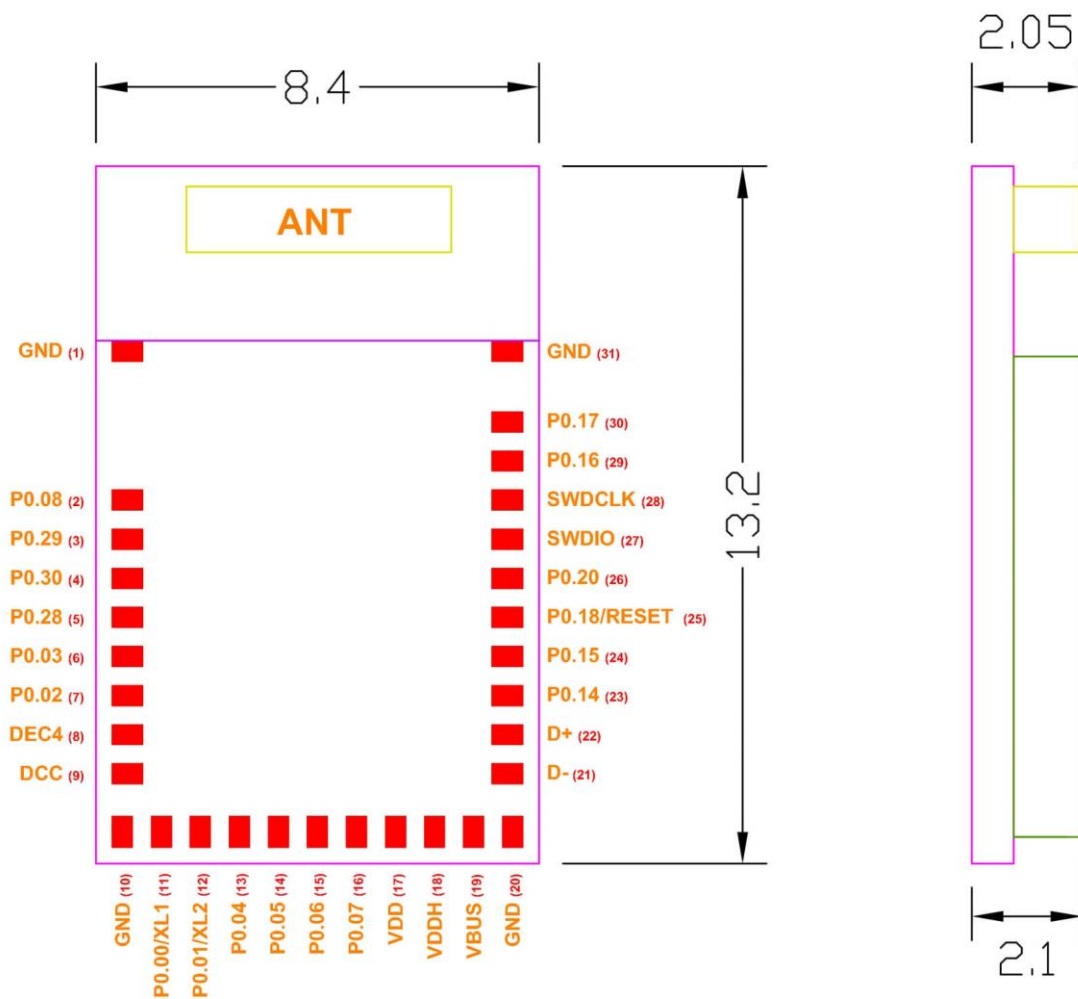

Top (Unit: mm)

• **MDBT50-P256R**

PCB Size (in mm)			
	Min.	Norm	MAX.
L		13.2	
W	- 0.15	8.4	+ 0.2
H		2.1	

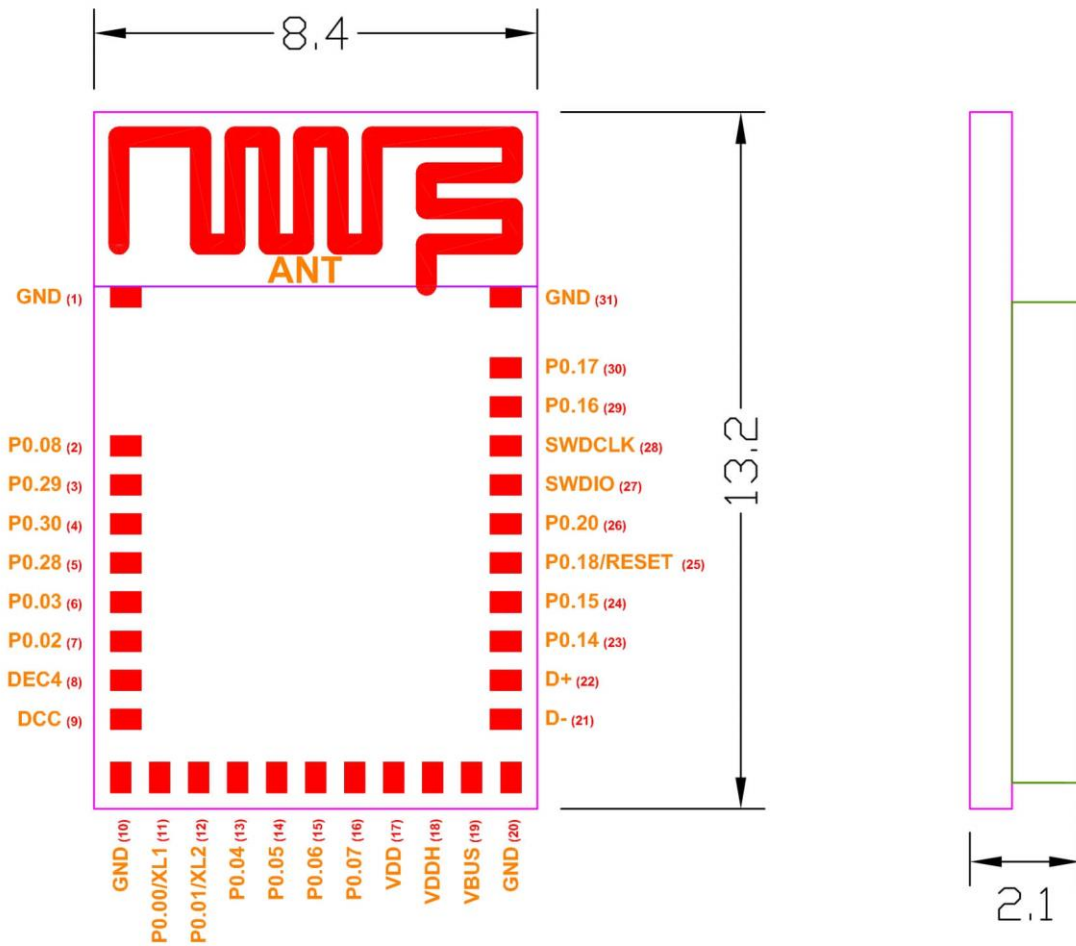

Top (Unit: mm)

2.2. Recommended Layout of Solder Pad

Graphs are all in Top View, Unit in mm.

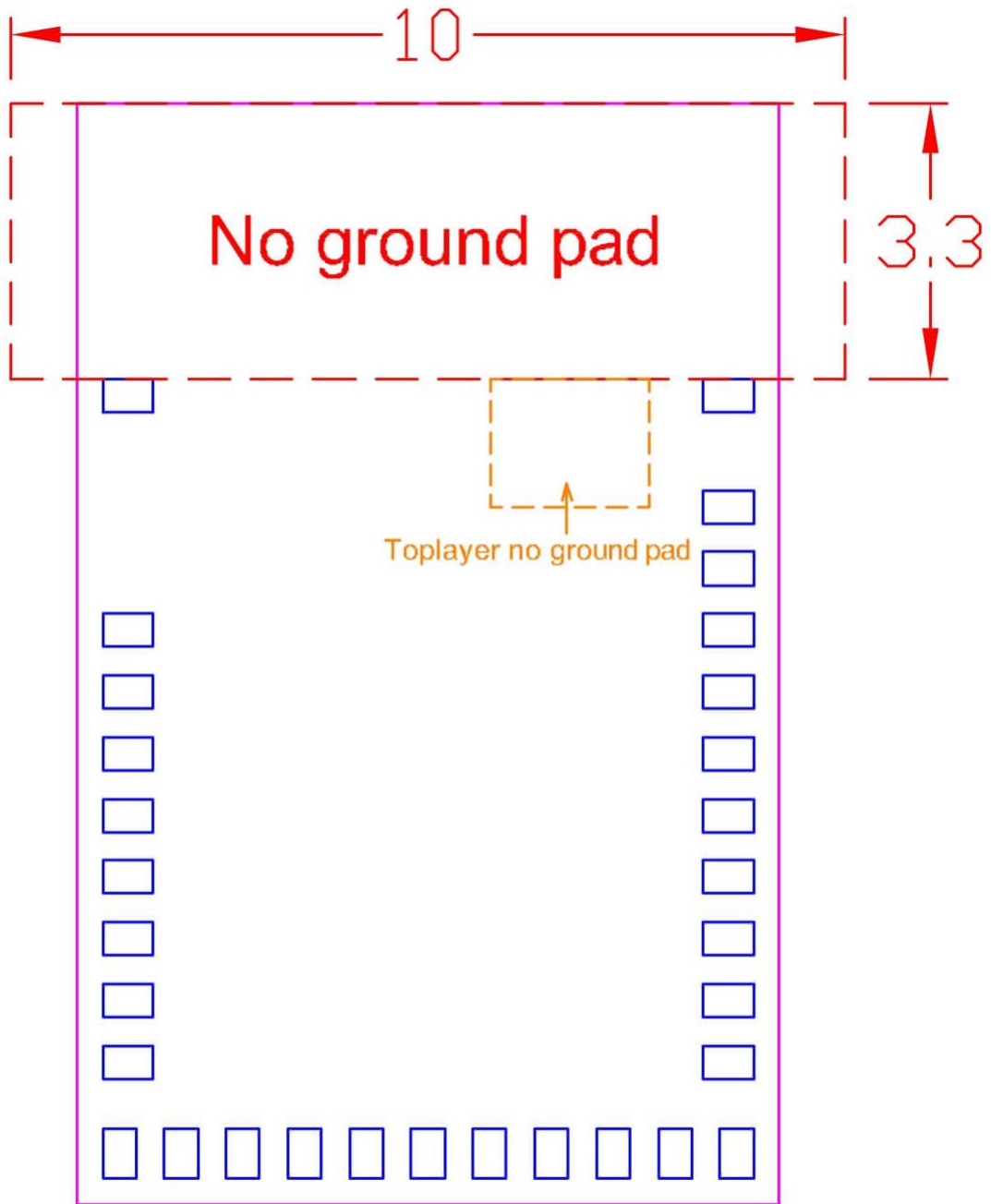

No ground pad

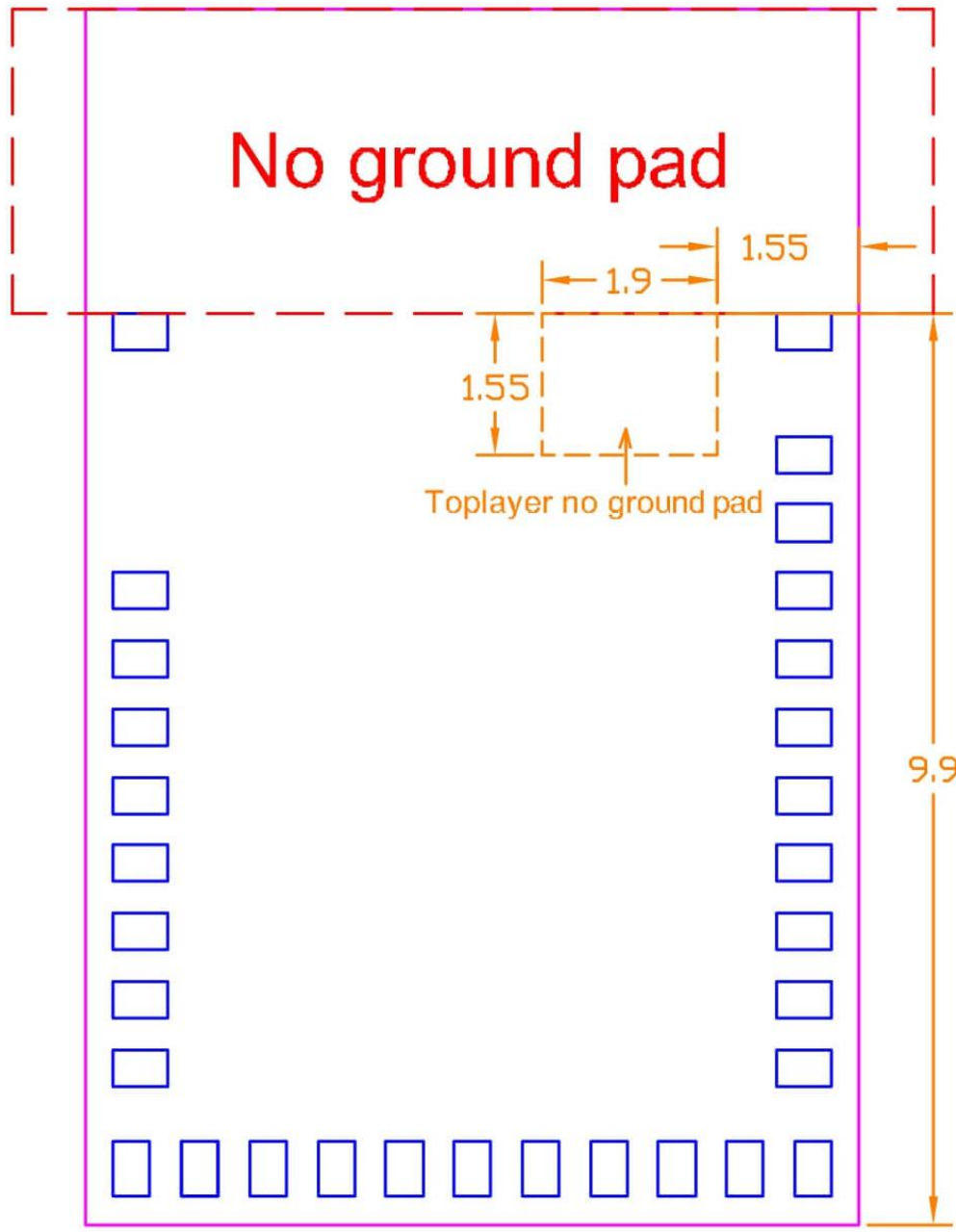

Toplayer no ground pad

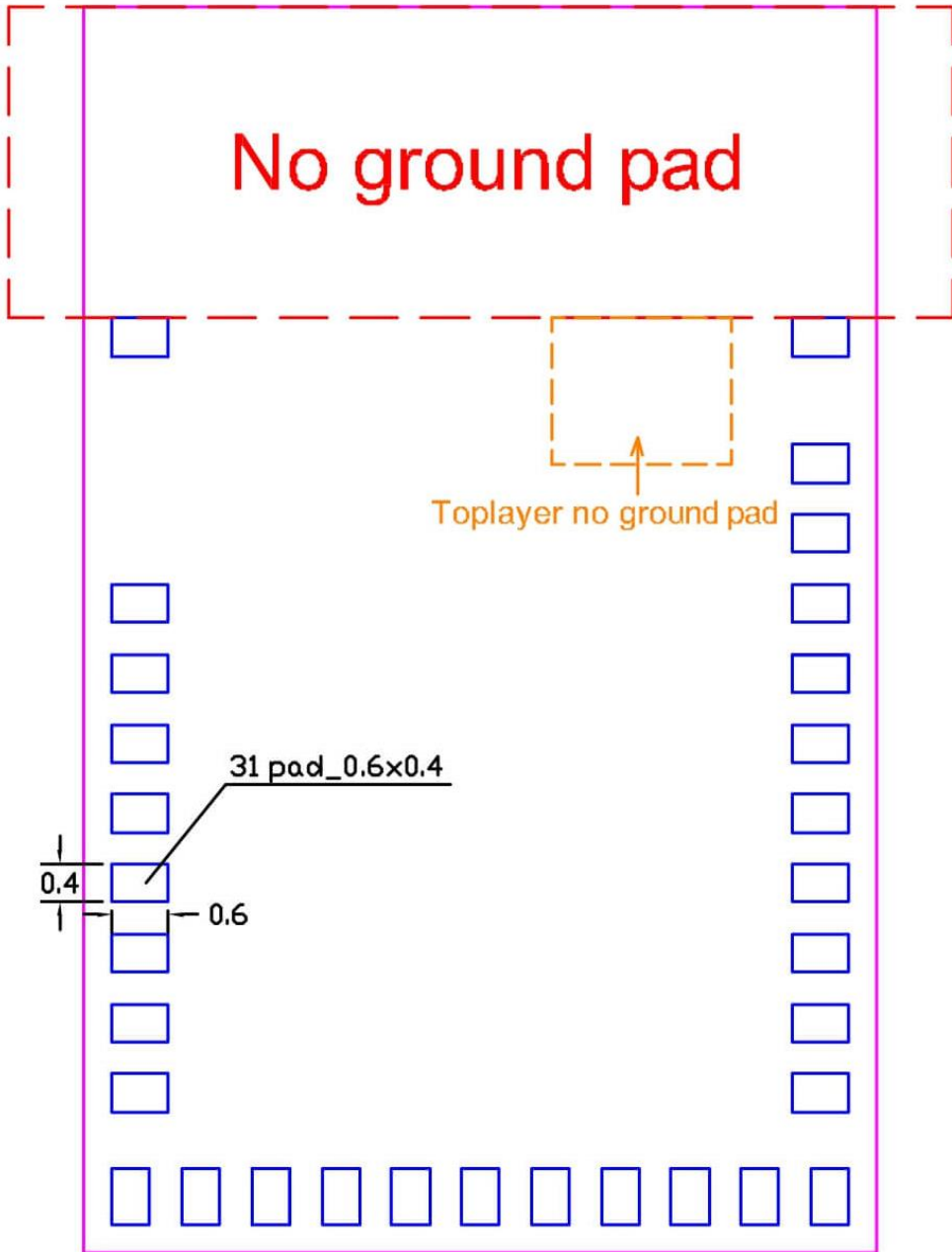

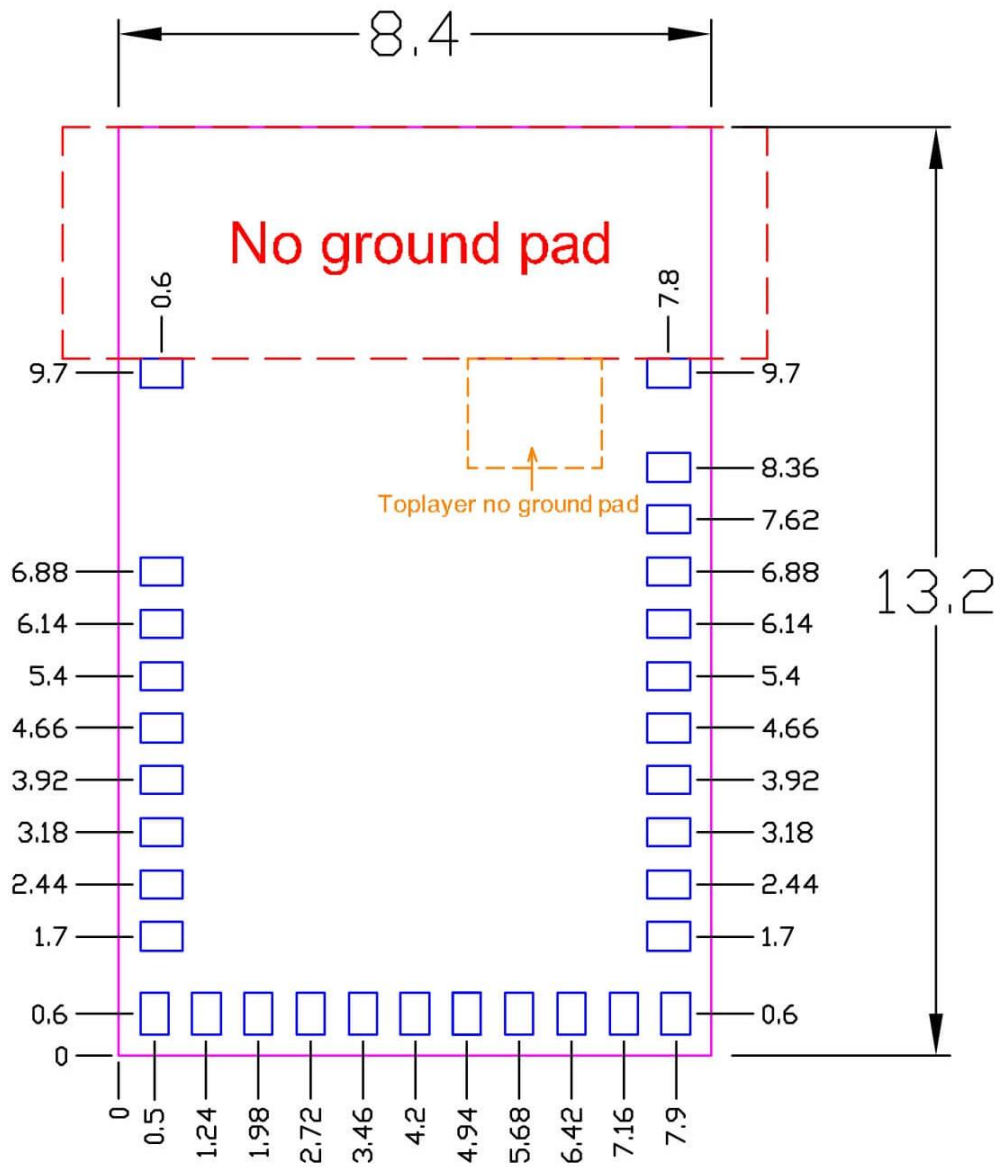

Top View (Unit : mm)
recommended solder pad layout

2.3. RF Layout Suggestion (aka Keep-Out Area)

Make sure to keep the “No Ground Pad” as wider as you can regardless of the size of your PCB.

No Ground Pad should be included in the corresponding position of the antenna in **EACH LAYER**.

Place the module towards the edge of PCB to have better performance than placing it on the center.

Welcome to send us your layout in PDF for review at service@raytac.com or your contact at Raytac with title “Layout reviewing – Raytac Model No. – YOUR company’s name”.

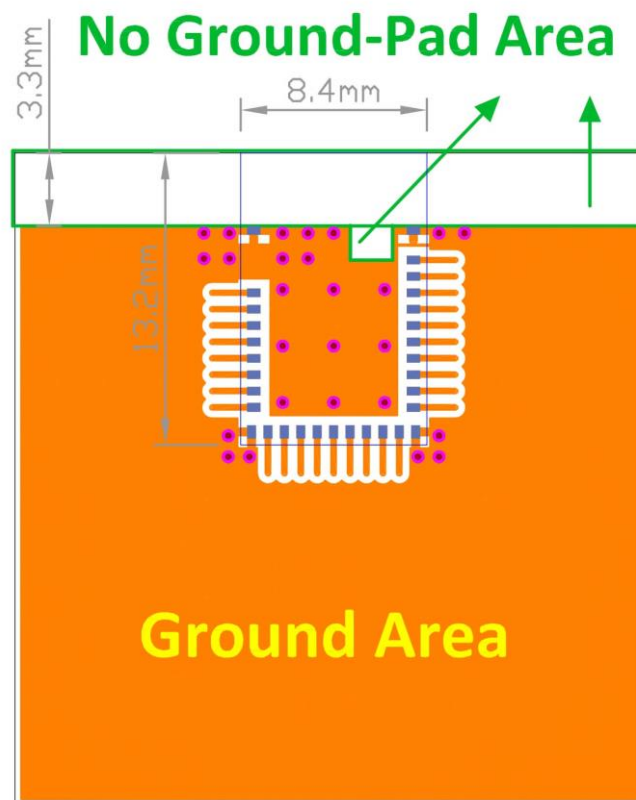

Top layer

Please add via holes in GROUND area as many as possible, especially around the four corners.

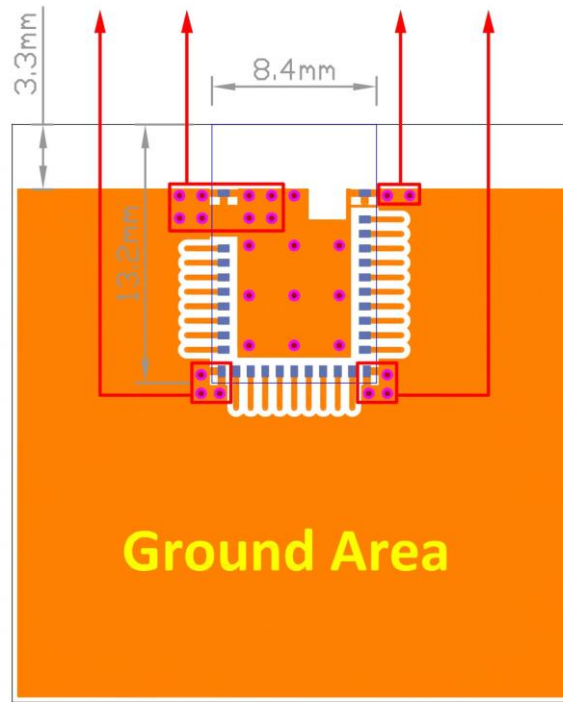

Top layer

No Ground-Pad Area

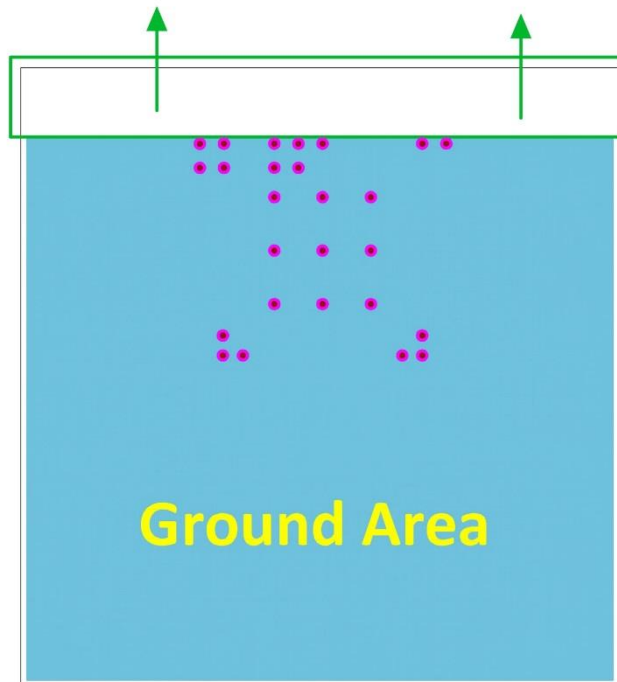

Bottom layer

Examples of “NOT RECOMMENDED” layout

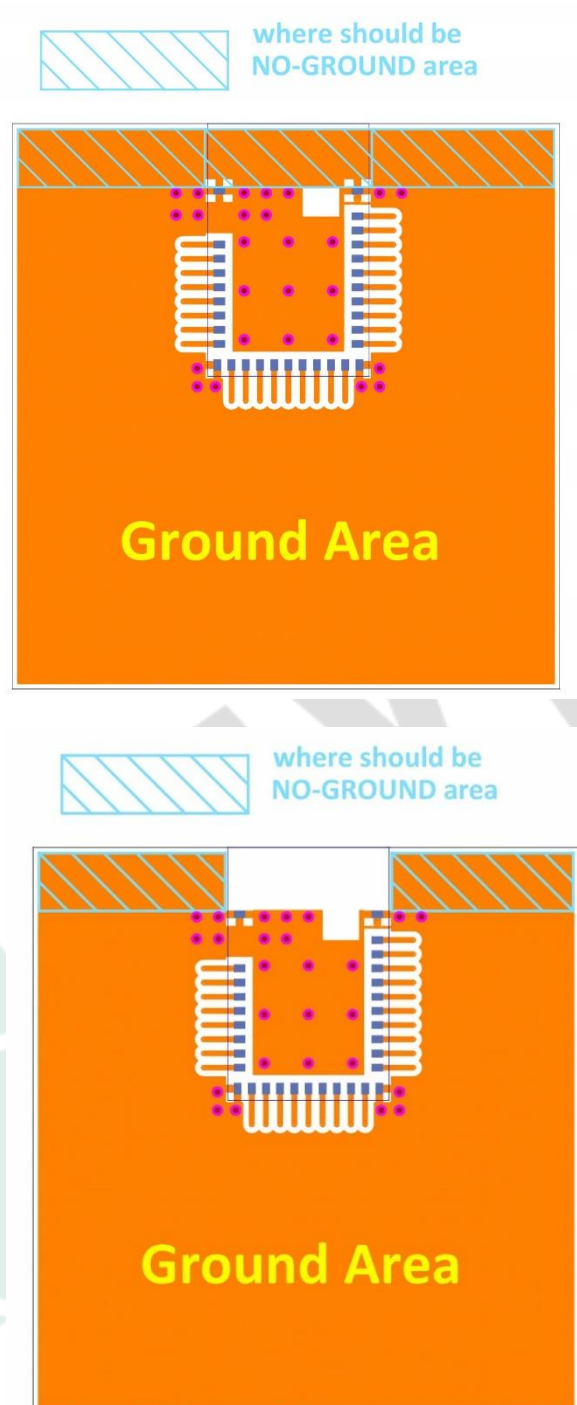

2.4. Footprint & Design Guide

Please visit “[Support](#)” page of our website to download. The package includes footprint, 2D/3D drawing, reflow graph/solder profile and recommended spec for external 32.768khz.

2.5. Pin Assignment

Pin No.	Name	Pin function	Description
(1)	GND	Power	Ground
(2)	P0.08	Digital I/O	General-purpose I/O (standard drive, low frequency I/O only)
(3)	P0.29	Digital I/O	General-purpose I/O (standard drive, low frequency I/O only)
(4)	P0.30	Digital I/O	General-purpose I/O (standard drive, low frequency I/O only)
(5)	P0.28	Digital I/O	General-purpose I/O (standard drive, low frequency I/O only)
(6)	P0.03	Digital I/O	General-purpose I/O (standard drive, low frequency I/O only)
	AIN1	Analog input	Analog input
(7)	P0.02	Digital I/O	General-purpose I/O
	AIN0	Analog input	Analog input
(8)	DEC4	Power	1.3V regulator supply decoupling
(9)	DCC	Power	DC/DC converter output
(10)	GND	Power	Ground
(11)	P0.00	Digital I/O	General-purpose I/O
	XL1	Analog input	Connection for 32.768 kHz crystal
(12)	P0.01	Digital I/O	General-purpose I/O
	XL2	Analog input	Connection for 32.768 kHz crystal
(13)	P0.04	Digital I/O	General-purpose I/O
	AIN2	Analog input	Analog input
(14)	P0.05	Digital I/O	General-purpose I/O
	AIN3	Analog input	Analog input
(15)	P0.06	Digital I/O	General-purpose I/O
(16)	P0.07	Digital I/O	General-purpose I/O
(17)	VDD	Power	Power supply
(18)	VDDH	Power	High voltage power supply

Pin No.	Name	Pin Function	Description
(19)	VBUS	Power	5V input for USB 3.3V regulator
(20)	GND	Power	Ground
(21)	D-	Digital I/O	USB D-
(22)	D+	Digital I/O	USB D+
(23)	P0.14	Digital I/O	General-purpose I/O
(24)	P0.15	Digital I/O	General-purpose I/O
(25)	P0.18	Digital I/O	General-purpose I/O
	nRESET		Configurable as system RESET
(26)	P0.20	Digital I/O	General-purpose I/O
(27)	SWDIO	Debug	Debug serial debug I/O for debug and programming
(28)	SWDCLK	Debug	Debug serial debug clock input for debug and programming
(29)	P0.16	Digital I/O	General-purpose I/O (standard drive, low frequency I/O only)
(30)	P0.17	Digital I/O	General-purpose I/O (standard drive, low frequency I/O only)
(31)	GND	Power	Ground

2.6. GPIO Located Near the Radio

Please refer to [2.5 Pin Assignment](#) on page 14 to 16 where identifies some GPIO that have recommended usage. To maximize RF performance, these GPIO are only available to use under standard drive, low frequency I/O only, wrong usage may lead to undesirable performance.

Low frequency I/O is a signal with a frequency up to 10 kHz. SPI, I2C, UART, PWM are NOT low frequency I/O.



3. Main Chip Solution

RF IC	Crystal Frequency
Nordic NRF52820	32MHZ

32MHz crystal is already inside the module.



4. Shipment Packaging Information

Model	Antenna	Photo
MDBT50-256R	Chip/Ceramic	
MDBT50-P256R	PCB/Printed	

- Unit Weight of Module:

MDBT50-256R: 0.47 g (± 0.02 g) ; MDBT50-P256R: 0.45 g (± 0.02 g)

- Packaging Type: Anti-static tray or Tape & Reel

	Tray	Tape & Reel
MPQ (Min. Package Q'ty)	120 pcs per tray	1,500 pcs per reel
Carton Contents (per carton)	2,400 pcs	1,500 pcs
Carton Dimension (L) x (W) x (H) cm	37 x 21 x 13	37 x 36 x 6
Gross Weight	about 2.4 kgs	about 1.9 kgs

4.1. Marking on Metal Shield

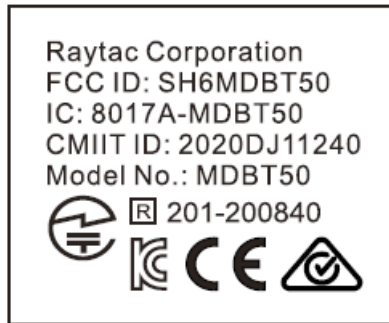

4.2. Packaging Info

4.2.1. Tray Packaging

Anti-static tray is specifically designed for mass production. It can be used directly on SMT automatic machine.

Before July 1st, 2022

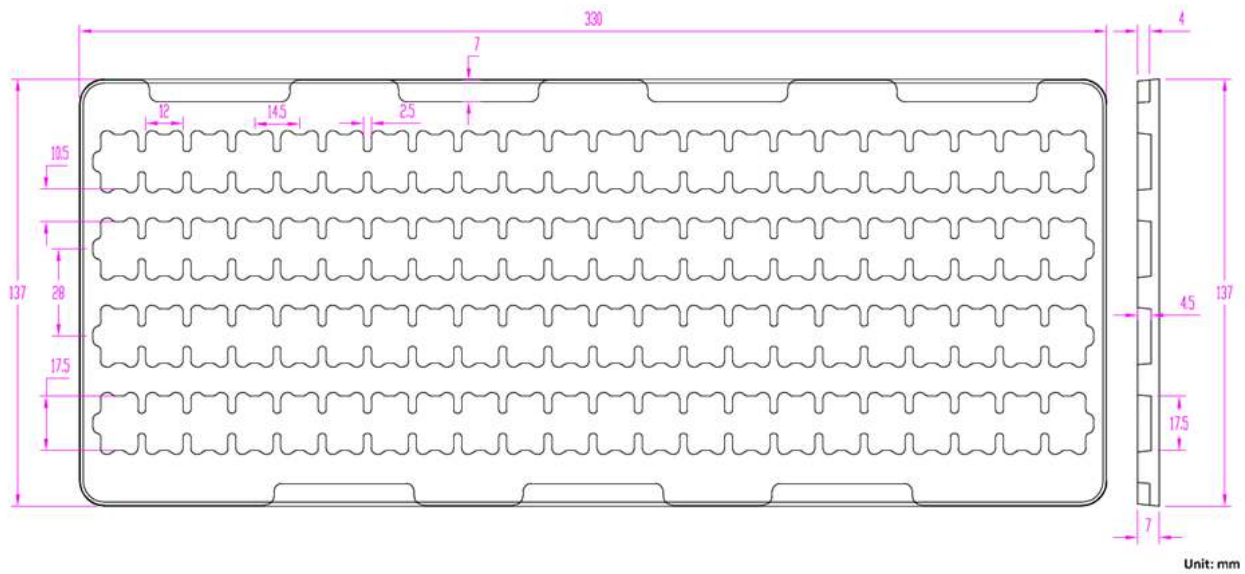

After July 1st, 2022

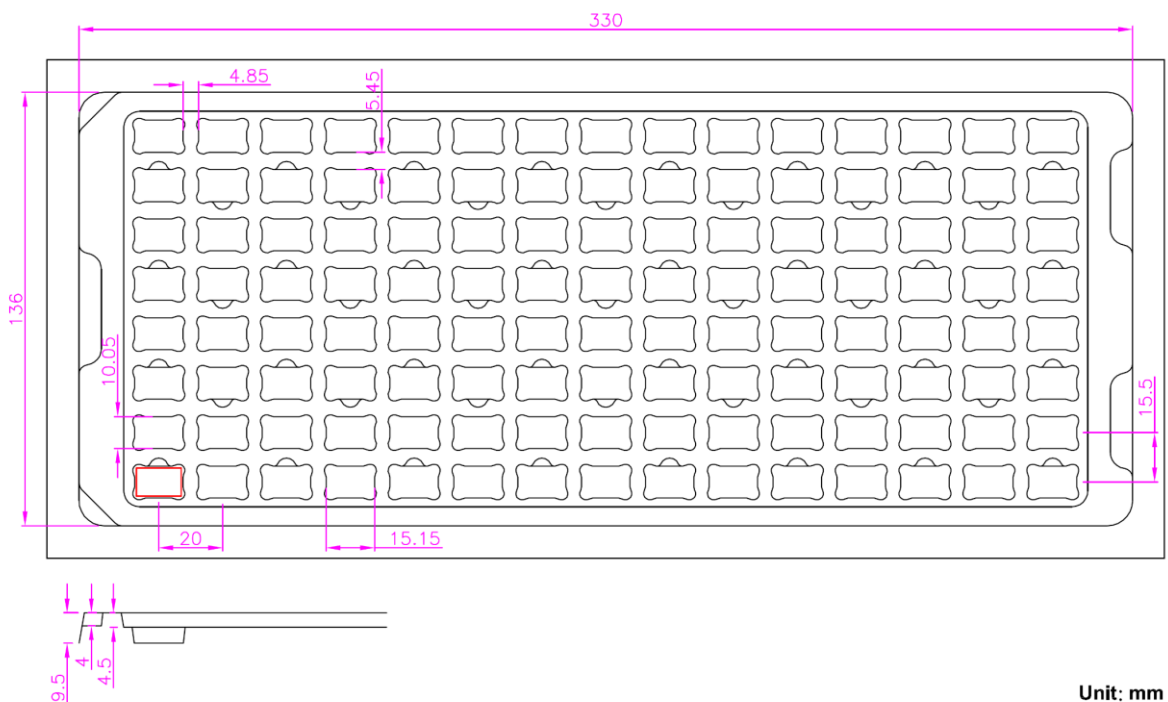

4.1
4

Unit: mm

4.2.2. Tape & Reel Packaging

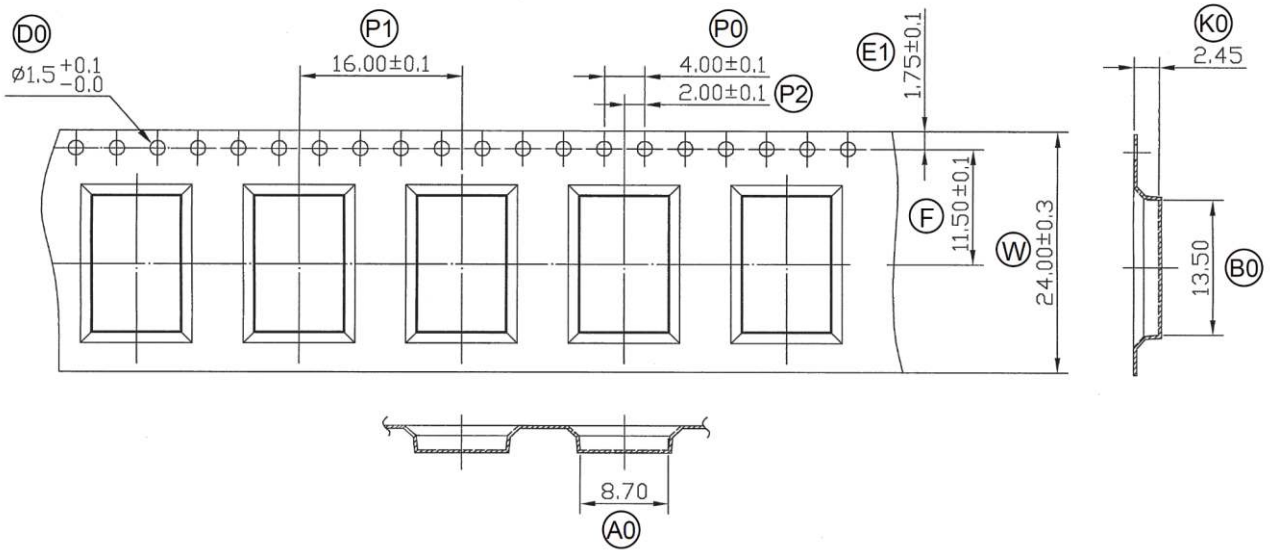

W	24.00	±0.30
P1	16.00	±0.10
E1	1.75	±0.10
F	11.50 ± 0.10	
D0	1.50	+0.1/-0
P0	4.00	±0.10
P2	2.00 ± 0.10	
A0	8.70	±0.10
B0	13.50	±0.10
K0	2.45	±0.10
T	0.30	±0.05

4.3. Order Code

Each model has two options of packaging. Please use following part no. when placing order to us.

Model	Tray	Tape & Reel
MDBT50-256R	MD-240A3-029	MD-240A3-029R
MDBT50-P256R	MD-240A3-030	MD-240A3-030R

MPQ of Reel packaging is 1,500 pcs and Tray packaging is 120 pcs.

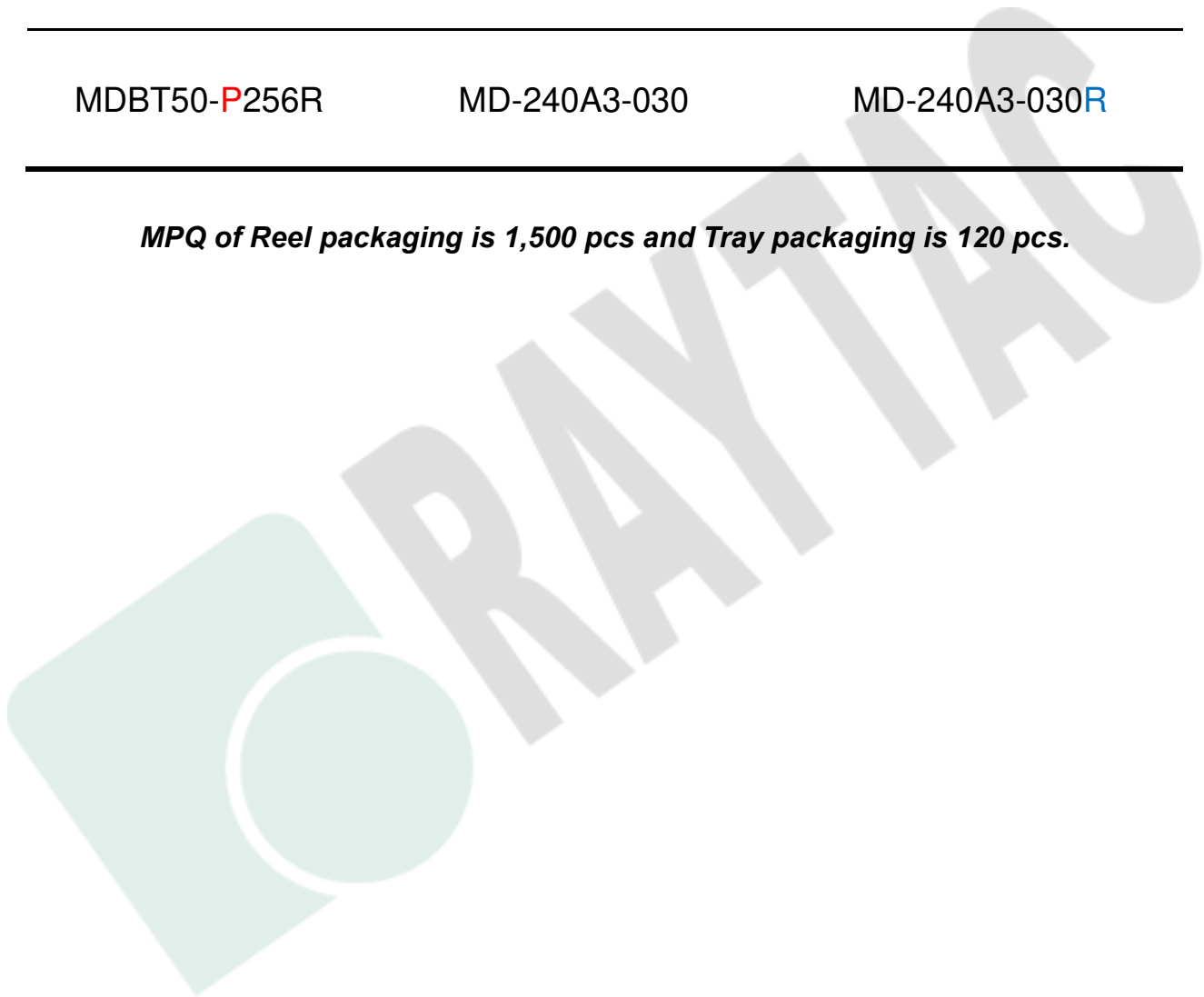

5. Specification

Any technical spec shall refer to Nordic's official documents as final reference. Contents below are from "[nRF52820 Production Specification v1.3](#)", please click to download full spec.

5.1. Absolute Maximum Ratings

	Note	Min.	Max.	Unit
Supply voltages				
VDD		-0.3	+3.9	V
VDDH		-0.3	+5.8	V
VBUS		-0.3	+5.8	V
VSS			0	V
I/O pin voltage				
$V_{I/O}$, VDD \leq 3.6 V		-0.3	VDD + 0.3	V
$V_{I/O}$, VDD > 3.6 V		-0.3	3.9	V
Environmental QFN40 package				
Storage temperature		-40	+125	°C
MSL	Moisture Sensitivity Level		2	
ESD HBM	Human Body Model		3	kV
ESD HBM Class	Human Body Model Class		2	
ESD CDM	Charged Device Model		1	kV
Flash memory				
Endurance		10 000		write/erase cycles
Retention at 85 °C		10		years
Retention at 105 °C	Limited to 1000 write/erase cycles	3		years
Retention at 105 °C-85 °C, execution split	Limited to 1000 write/erase cycles	6.7		years

75% execution time at 85 °C or less

5.2. Operating Conditions

Symbol	Parameter	Min.	Nom.	Max.	Units
VDD	VDD supply voltage, independent of DCDC enable	1.7	3.0	3.6	V
VDD _{POR}	VDD supply voltage needed during power-on reset	1.75			V
VDDH	VDDH supply voltage	2.5	3.7	5.5	V
VBUS	VBUS USB supply voltage	4.35	5.0	5.5	V
t _{R_VDD}	Supply rise time (0 V to 1.7 V)			60	ms
t _{R_VDDH}	Supply rise time (0 V to 3.7 V)			100	ms
TA	Operating temperature	-40	25	85	°C
TA _{EXT}	Extended operating temperature	85		105	°C
T _J	Junction temperature			110	°C

5.3. Electrical Specifications

5.3.1. General Radio Characteristics

Symbol	Description	Min.	Typ.	Max.	Units
f_{OP}	Operating frequencies	2360		2500	MHz
$f_{PLL,CH,SP}$	PLL channel spacing		1		MHz
$f_{DELTA,1M}$	Frequency deviation @ 1 Mbps		± 170		kHz
$f_{DELTA,BLE,1M}$	Frequency deviation @ BLE 1 Mbps		± 250		kHz
$f_{DELTA,2M}$	Frequency deviation @ 2 Mbps		± 320		kHz
$f_{DELTA,BLE,2M}$	Frequency deviation @ BLE 2 Mbps		± 500		kHz
f_{skBPS}	On-the-air data rate	125		2000	kbps
$f_{chip, IEEE 802.15.4}$	Chip rate in IEEE 802.15.4 mode		2000		kchips

5.3.2. Radio Current Consumption (Transmitter)

Symbol	Description	Min.	Typ.	Max.	Units
$I_{TX,PLUS8dBm,DCDC}$	TX only run current (DC/DC, 3 V) $P_{RF} = +8$ dBm		14.0		mA
$I_{TX,PLUS8dBm}$	TX only run current $P_{RF} = +8$ dBm		30.0		mA
$I_{TX,PLUS4dBm,DCDC}$	TX only run current (DC/DC, 3 V) $P_{RF} = +4$ dBm		9.4		mA
$I_{TX,PLUS4dBm}$	TX only run current $P_{RF} = +4$ dBm		20.4		mA
$I_{TX,0dBm,DCDC}$	TX only run current (DC/DC, 3 V) $P_{RF} = 0$ dBm		4.9		mA
$I_{TX,0dBm}$	TX only run current $P_{RF} = 0$ dBm		10.4		mA
$I_{TX,MINUS4dBm,DCDC}$	TX only run current DC/DC, 3 V $P_{RF} = -4$ dBm		3.8		mA
$I_{TX,MINUS4dBm}$	TX only run current $P_{RF} = -4$ dBm		8.1		mA
$I_{TX,MINUS8dBm,DCDC}$	TX only run current DC/DC, 3 V $P_{RF} = -8$ dBm		3.4		mA
$I_{TX,MINUS8dBm}$	TX only run current $P_{RF} = -8$ dBm		7.1		mA
$I_{TX,MINUS12dBm,DCDC}$	TX only run current DC/DC, 3 V $P_{RF} = -12$ dBm		3.1		mA
$I_{TX,MINUS12dBm}$	TX only run current $P_{RF} = -12$ dBm		6.4		mA
$I_{TX,MINUS16dBm,DCDC}$	TX only run current DC/DC, 3 V $P_{RF} = -16$ dBm		2.9		mA
$I_{TX,MINUS16dBm}$	TX only run current $P_{RF} = -16$ dBm		6.0		mA
$I_{TX,MINUS20dBm,DCDC}$	TX only run current DC/DC, 3 V $P_{RF} = -20$ dBm		2.7		mA
$I_{TX,MINUS20dBm}$	TX only run current $P_{RF} = -20$ dBm		5.6		mA
$I_{TX,MINUS40dBm,DCDC}$	TX only run current DC/DC, 3 V $P_{RF} = -40$ dBm		2.3		mA
$I_{TX,MINUS40dBm}$	TX only run current $P_{RF} = -40$ dBm		4.6		mA
$I_{START,TX,DCDC}$	TX start-up current DC/DC, 3 V, $P_{RF} = 4$ dBm		4.2		mA
$I_{START,TX}$	TX start-up current, $P_{RF} = 4$ dBm		8.8		mA

5.3.3. Radio Current Consumption (Receiver)

Symbol	Description	Min.	Typ.	Max.	Units
$I_{RX,1M,DCDC}$	RX only run current (DC/DC, 3 V) 1 Mbps/1 Mbps BLE		4.7		mA
$I_{RX,1M}$	RX only run current (LDO, 3 V) 1 Mbps/1 Mbps BLE		9.8		mA
$I_{RX,2M,DCDC}$	RX only run current (DC/DC, 3 V) 2 Mbps/2 Mbps BLE		5.2		mA
$I_{RX,2M}$	RX only run current (LDO, 3 V) 2 Mbps/2 Mbps BLE		10.9		mA
$I_{START,RX,1M,DCDC}$	RX start-up current (DC/DC, 3 V) 1 Mbps/1 Mbps BLE		3.4		mA
$I_{START,RX,1M}$	RX start-up current 1 Mbps/1 Mbps BLE		6.8		mA

5.3.4. Transmitter Specification

Symbol	Description	Min.	Typ.	Max.	Units
P_{RF}	Maximum output power		8		dBm
P_{RFC}	RF power control range		28		dB
P_{RFCR}	RF power accuracy			± 4	dB
$P_{RF1,1}$	1st Adjacent Channel Transmit Power 1 MHz (1 Mbps)		-25		dBc
$P_{RF2,1}$	2nd Adjacent Channel Transmit Power 2 MHz (1 Mbps)		-54		dBc
$P_{RF1,2}$	1st Adjacent Channel Transmit Power 2 MHz (2 Mbps)		-26		dBc
$P_{RF2,2}$	2nd Adjacent Channel Transmit Power 4 MHz (2 Mbps)		-54		dBc
E_{vm}	Error vector magnitude in IEEE 802.15.4 mode (Offset EVM)		2		%rms
$P_{harm2nd, IEEE 802.15.4}$	2nd harmonics in IEEE 802.15.4 mode		-49		dBm
$P_{harm3rd, IEEE 802.15.4}$	3rd harmonics in IEEE 802.15.4 mode		-54		dBm

5.3.5. RSSI Specifications

Symbol	Description	Min.	Typ.	Max.	Units
$RSSI_{ACC}$	RSSI accuracy valid range -90 to -30 dBm		± 2		dB
$RSSI_{RESOLUTION}$	RSSI resolution		1		dB
$RSSI_{PERIOD}$	RSSI sampling time from $RSSI_START$ task		0.25		μs
$RSSI_{SETTLE}$	RSSI settling time after signal level change		15		μs

5.3.6. Receiver Operation

Symbol	Description	Min.	Typ.	Max.	Units
$P_{RX,MAX}$	Maximum received signal strength at < 0.1% PER		0		dBm
$P_{SENS,IT,1M}$	Sensitivity, 1 Mbps nRF mode ideal transmitter ¹		-92		dBm
$P_{SENS,IT,2M}$	Sensitivity, 2 Mbps nRF mode ideal transmitter ¹		-89		dBm
$P_{SENS,IT,SP,1M,BLE}$	Sensitivity, 1 Mbps BLE ideal transmitter, packet length ≤ 37 bytes BER= $1E-3$ ²		-95		dBm
$P_{SENS,IT,LP,1M,BLE}$	Sensitivity, 1 Mbps BLE ideal transmitter, packet length ≥ 128 bytes BER= $1E-4$ ³		-94		dBm
$P_{SENS,IT,SP,2M,BLE}$	Sensitivity, 2 Mbps BLE ideal transmitter, packet length ≤ 37 bytes		-92		dBm
$P_{SENS,IT,BLE,LE125k}$	Sensitivity, 125 kbps BLE mode		-103		dBm
$P_{SENS,IT,BLE,LE500k}$	Sensitivity, 500 kbps BLE mode		-98		dBm
$P_{SENS,IEEE,802.15.4}$	Sensitivity in IEEE 802.15.4 mode		-99		dBm

Remark:

1. Typical sensitivity applies when ADDR0 is used for receiver address correlation. When ADDR[1...7] are used for receiver address correlation, the typical sensitivity for this mode is degraded by 3 dB.
2. As defined in the Bluetooth Core Specification v4.0 Volume 6: Core System Package (Low Energy Controller Volume).
3. Equivalent BER limit < 10E-04.

5.3.7. RX Selectivity

Symbol	Description	Min.	Typ.	Max.	Units
$C/I_{1M,co-channel}$	1Mbps mode, co-channel interference		10		dB
$C/I_{1M,-1MHz}$	1 Mbps mode, Adjacent (-1 MHz) interference		-5		dB
$C/I_{1M,+1MHz}$	1 Mbps mode, Adjacent (+1 MHz) interference		-14		dB
$C/I_{1M,-2MHz}$	1 Mbps mode, Adjacent (-2 MHz) interference		-25		dB
$C/I_{1M,+2MHz}$	1 Mbps mode, Adjacent (+2 MHz) interference		-45		dB
$C/I_{1M,-3MHz}$	1 Mbps mode, Adjacent (-3 MHz) interference		-40		dB
$C/I_{1M,+3MHz}$	1 Mbps mode, Adjacent (+3 MHz) interference		-46		dB
$C/I_{1M,\pm 6MHz}$	1 Mbps mode, Adjacent (≥ 6 MHz) interference		-52		dB
$C/I_{1MBLE,co-channel}$	1 Mbps BLE mode, co-channel interference		6		dB
$C/I_{1MBLE,-1MHz}$	1 Mbps BLE mode, Adjacent (-1 MHz) interference		-2		dB
$C/I_{1MBLE,+1MHz}$	1 Mbps BLE mode, Adjacent (+1 MHz) interference		-10		dB
$C/I_{1MBLE,-2MHz}$	1 Mbps BLE mode, Adjacent (-2 MHz) interference		-28		dB
$C/I_{1MBLE,+2MHz}$	1 Mbps BLE mode, Adjacent (+2 MHz) interference		-45		dB
$C/I_{1MBLE,>3MHz}$	1 Mbps BLE mode, Adjacent (≥ 3 MHz) interference		-54		dB
$C/I_{1MBLE,image}$	Image frequency interference		-28		dB
$C/I_{1MBLE,image,1MHz}$	Adjacent (1 MHz) interference to in-band image frequency		-37		dB

Symbol	Description	Min.	Typ.	Max.	Units
$C/I_{2M,co-channel}$	2 Mbps mode, co-channel interference		10		dB
$C/I_{2M,-2MHz}$	2 Mbps mode, Adjacent (-2 MHz) interference		-4		dB
$C/I_{2M,+2MHz}$	2 Mbps mode, Adjacent (+2 MHz) interference		-16		dB
$C/I_{2M,-4MHz}$	2 Mbps mode, Adjacent (-4 MHz) interference		-22		dB
$C/I_{2M,+4MHz}$	2 Mbps mode, Adjacent (+4 MHz) interference		-46		dB
$C/I_{2M,-6MHz}$	2 Mbps mode, Adjacent (-6 MHz) interference		-39		dB
$C/I_{2M,+6MHz}$	2 Mbps mode, Adjacent (+6 MHz) interference		-48		dB
$C/I_{2M,\geq 12MHz}$	2 Mbps mode, Adjacent (≥ 12 MHz) interference		-52		dB
$C/I_{2M BLE,co-channel}$	2 Mbps BLE mode, co-channel interference		7		dB
$C/I_{2M BLE,-2MHz}$	2 Mbps BLE mode, Adjacent (-2 MHz) interference		-2		dB
$C/I_{2M BLE,+2MHz}$	2 Mbps BLE mode, Adjacent (+2 MHz) interference		-12		dB
$C/I_{2M BLE,-4MHz}$	2 Mbps BLE mode, Adjacent (-4 MHz) interference		-25		dB
$C/I_{2M BLE,+4MHz}$	2 Mbps BLE mode, Adjacent (+4 MHz) interference		-46		dB
$C/I_{2M BLE,\geq 6MHz}$	2 Mbps BLE mode, Adjacent (≥ 6 MHz) interference		-54		dB
$C/I_{2M BLE,image}$	Image frequency interference		-25		dB
$C/I_{2M BLE,image, 2MHz}$	Adjacent (2 MHz) interference to in-band image frequency		-37		dB
$C/I_{125k BLE LR,co-channel}$	125 kbps BLE LR mode, co-channel interference		3		dB
$C/I_{125k BLE LR,-1MHz}$	125 kbps BLE LR mode, Adjacent (-1 MHz) interference		-9		dB
$C/I_{125k BLE LR,+1MHz}$	125 kbps BLE LR mode, Adjacent (+1 MHz) interference		-16		dB
$C/I_{125k BLE LR,-2MHz}$	125 kbps BLE LR mode, Adjacent (-2 MHz) interference		-28		dB
$C/I_{125k BLE LR,+2MHz}$	125 kbps BLE LR mode, Adjacent (+2 MHz) interference		-54		dB
$C/I_{125k BLE LR,>3MHz}$	125 kbps BLE LR mode, Adjacent (≥ 3 MHz) interference		-60		dB
$C/I_{125k BLE LR,image}$	Image frequency interference		-28		dB
$C/I_{IEEE 802.15.4,-5MHz}$	IEEE 802.15.4 mode, Adjacent (-5 MHz) rejection		-33		dB
$C/I_{IEEE 802.15.4,+5MHz}$	IEEE 802.15.4 mode, Adjacent (+5 MHz) rejection		-38		dB
$C/I_{IEEE 802.15.4,\pm 10MHz}$	IEEE 802.15.4 mode, Alternate (± 10 MHz) rejection		-49		dB

Desired signal level at PIN = -67 dBm. One interferer is used, having equal modulation as the desired signal. The input power of the interferer where the sensitivity equals BER = 0.1% is presented.

5.3.8. RX Intermodulation

Symbol	Description	Min.	Typ.	Max.	Units
P _{IMD,5TH,1M}	IMD performance, 1 Mbps, 5th offset channel, packet length ≤ 37 bytes		-34		dBm
P _{IMD,5TH,1M,BLE}	IMD performance, BLE 1 Mbps, 5th offset channel, packet length ≤ 37 bytes		-32		dBm
P _{IMD,5TH,2M}	IMD performance, 2 Mbps, 5th offset channel, packet length ≤ 37 bytes		-33		dBm
P _{IMD,5TH,2M,BLE}	IMD performance, BLE 2 Mbps, 5th offset channel, packet length ≤ 37 bytes		-32		dBm

Remark: Desired signal level at PIN = -64 dBm. Two interferers with equal input power are used. The interferer closest in frequency is not modulated, the other interferer is modulated equal with the desired signal. The input power of the interferers where the sensitivity equals BER = 0.1% is presented.

5.3.9. Radio Timing Parameters

Symbol	Description	Min.	Typ.	Max.	Units
t _{TXEN,BLE,1M}	Time between TXEN task and READY event after channel FREQUENCY configured (1 Mbps BLE and 150 μs TIFS)		140		μs
t _{TXEN,FAST,BLE,1M}	Time between TXEN task and READY event after channel FREQUENCY configured (1 Mbps BLE with fast ramp-up and 150 μs TIFS)		40		μs
t _{TXDIS,BLE,1M}	When in TX, delay between DISABLE task and DISABLED event for MODE = Nrf_1Mbit and MODE = Ble_1Mbit		6		μs
t _{RXEN,BLE,1M}	Time between the RXEN task and READY event after channel FREQUENCY configured (1 Mbps BLE)		140		μs
t _{RXEN,FAST,BLE,1M}	Time between the RXEN task and READY event after channel FREQUENCY configured (1 Mbps BLE with fast ramp-up)		40		μs
t _{RXDIS,BLE,1M}	When in RX, delay between DISABLE task and DISABLED event for MODE = Nrf_1Mbit and MODE = Ble_1Mbit		0		μs
t _{TXDIS,BLE,2M}	When in TX, delay between DISABLE task and DISABLED event for MODE = Nrf_2Mbit and MODE = Ble_2Mbit		4		μs
t _{RXDIS,BLE,2M}	When in RX, delay between DISABLE task and DISABLED event for MODE = Nrf_2Mbit and MODE = Ble_2Mbit		0		μs
t _{TXEN,IEEE 802.15.4}	Time between TXEN task and READY event after channel FREQUENCY configured (IEEE 802.15.4 mode)		130		μs
t _{TXEN,FAST,IEEE 802.15.4}	Time between TXEN task and READY event after channel FREQUENCY configured (IEEE 802.15.4 mode with fast ramp-up)		40		μs
t _{TXDIS,IEEE 802.15.4}	When in TX, delay between DISABLE task and DISABLED event (IEEE 802.15.4 mode)		21		μs
t _{RXEN,IEEE 802.15.4}	Time between the RXEN task and READY event after channel FREQUENCY configured (IEEE 802.15.4 mode)		130		μs
t _{RXEN,FAST,IEEE 802.15.4}	Time between the RXEN task and READY event after channel FREQUENCY configured (IEEE 802.15.4 mode with fast ramp-up)		40		μs
t _{RXDIS,IEEE 802.15.4}	When in RX, delay between DISABLE task and DISABLED event (IEEE 802.15.4 mode)		0.5		μs
t _{RX-to-TX turnaround}	Maximum TX-to-RX or RX-to-TX turnaround time in IEEE 802.15.4 mode		40		μs

5.3.10. CPU

Symbol	Description	Min.	Typ.	Max.	Units
W _{FLASH}	CPU wait states, running CoreMark from flash			2	
W _{RAM}	CPU wait states, running CoreMark from RAM			0	
CM _{FLASH}	CoreMark, running CoreMark from flash		144		CoreMark
CM _{FLASH/MHz}	CoreMark per MHz, running CoreMark from flash		2.3		CoreMark/MHz
CM _{FLASH/ma}	CoreMark per mA, running CoreMark from flash, DCDC 3V		68.6		CoreMark/mA

5.3.11. Power Management

Symbol	Description	Min.	Typ.	Max.	Units
I _{ON_RAMOFF_EVENT}	System ON, no RAM retention, wake on any event		0.4		μA
I _{ON_RAMON_EVENT}	System ON, full 32 kB RAM retention, wake on any event		0.6		μA
I _{ON_RAMON_POF}	System ON, full 32 kB RAM retention, wake on any event, power-fail comparator enabled		0.8		μA
I _{ON_RAMON_GPIOTE}	System ON, full 32 kB RAM retention, wake on GPIOTE input (event mode)		2.5		μA
I _{ON_RAMON_GPIOTEPORT}	System ON, full 32 kB RAM retention, wake on GPIOTE PORT event		0.6		μA
I _{ON_RAMOFF_RTC}	System ON, no RAM retention, wake on RTC (running from LFRC clock)		1.2		μA
I _{ON_RAMON_RTC}	System ON, full 32 kB RAM retention, wake on RTC (running from LFRC clock)		1.4		μA
I _{OFF_RAMOFF_RESET}	System OFF, no RAM retention, wake on reset		0.3		μA
I _{OFF_RAMON_RESET}	System OFF, full 32 kB RAM retention, wake on reset		0.5		μA
I _{ON_RAMOFF_EVENT_5V}	System ON, no RAM retention, wake on any event, 5 V supply on VDDH, REG0 output = 3.3 V		0.9		μA
I _{OFF_RAMOFF_RESET_5V}	System OFF, no RAM retention, wake on reset, 5 V supply on VDDH, REG0 output = 3.3 V		0.7		μA

6. Block Diagram

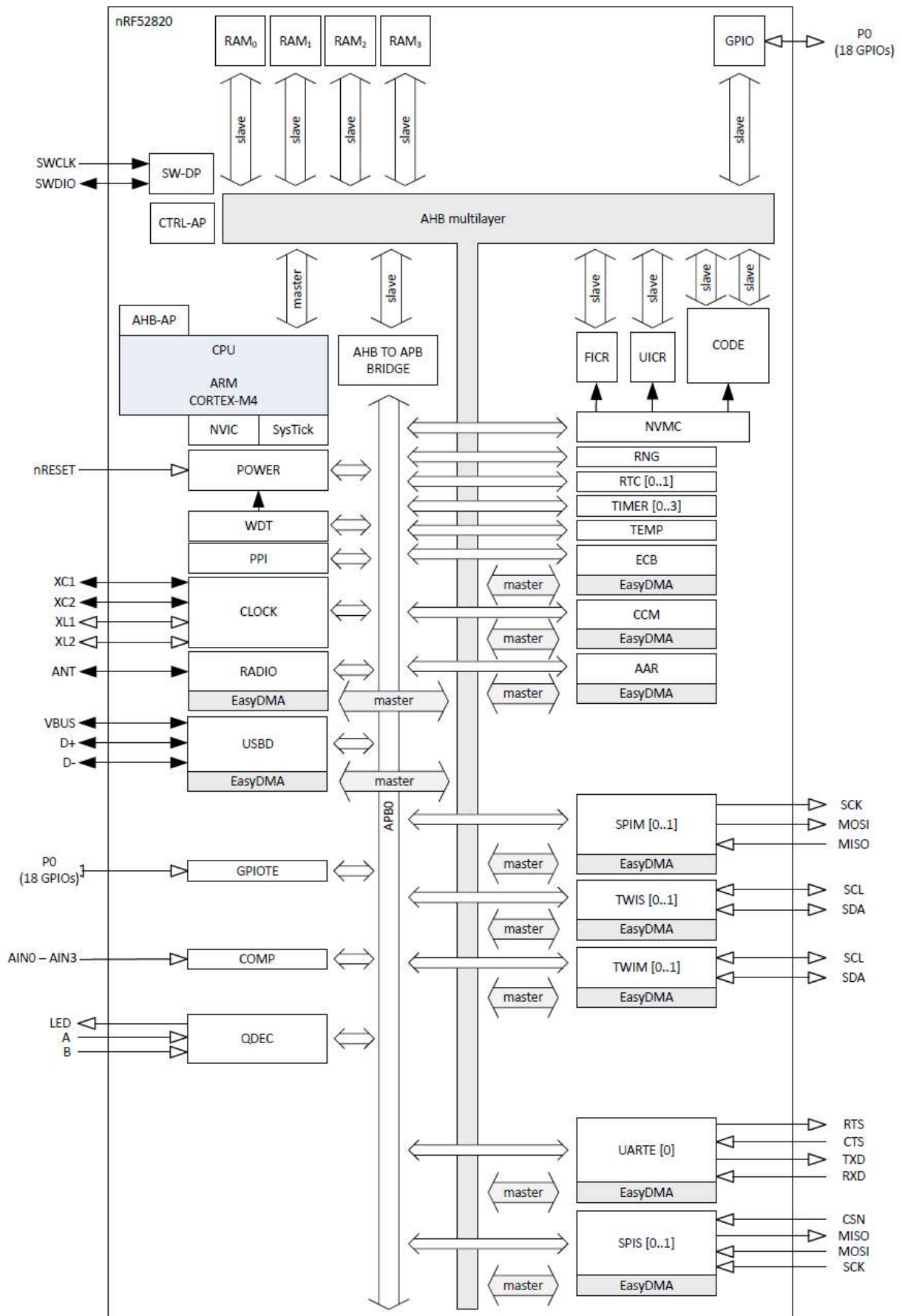

7. Antenna

7.1. MDBT50

Freq(MHz)	Peak. dBi	Efficiency	Average . dBi
2400.00	-3.90	14.14%	-8.50
2410.00	-3.52	15.66%	-8.05
2420.00	-3.34	16.67%	-7.78
2430.00	-3.05	17.48%	-7.58
2440.00	-3.06	17.60%	-7.54
2450.00	-3.32	16.58%	-7.80
2460.00	-3.73	14.27%	-8.46
2470.00	-4.22	12.85%	-8.91
2480.00	-4.58	12.38%	-9.07
2490.00	-4.87	11.78%	-9.29
2500.00	-5.59	9.40%	-10.27

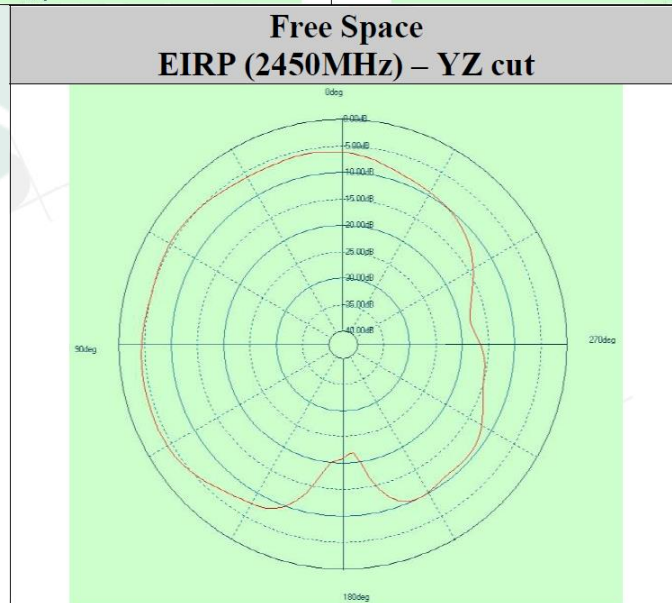
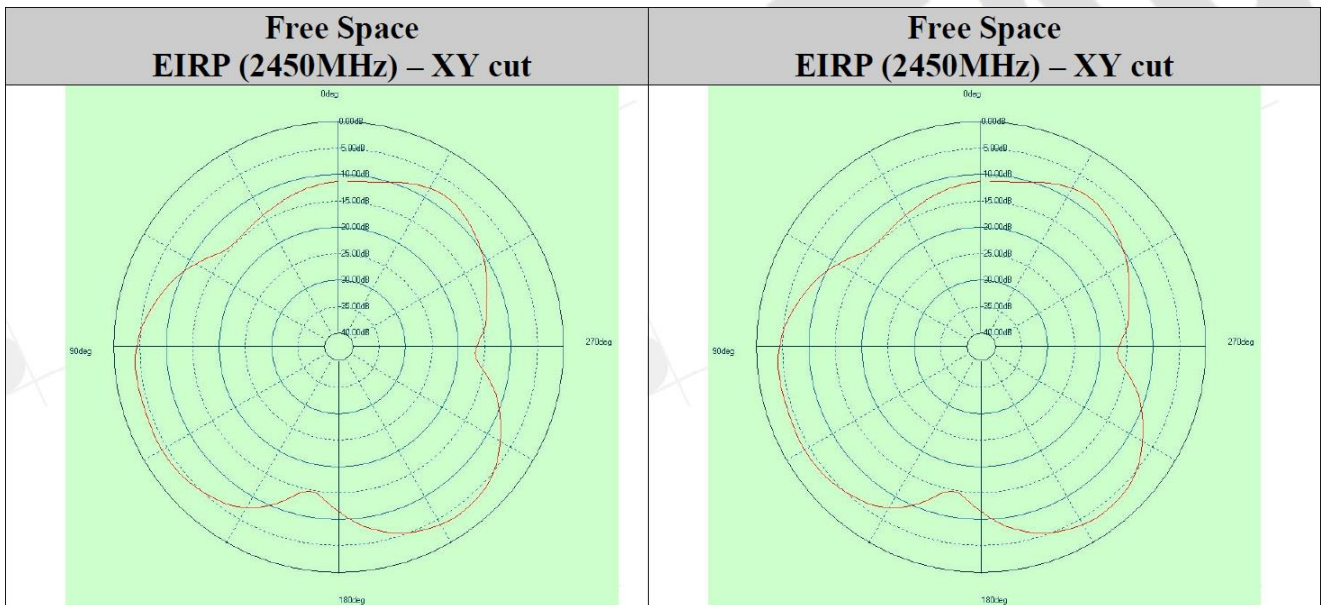

7.2. MDBT50-P

Freq(MHz)	Peak. dBi	Efficiency	Average . dBi
2400.00	-3.55	15.01%	-8.24
2410.00	-3.51	15.35%	-8.14
2420.00	-3.43	15.65%	-8.05
2430.00	-3.24	16.26%	-7.89
2440.00	-3.34	15.89%	-7.99
2450.00	-3.72	14.62%	-8.35
2460.00	-4.19	13.32%	-8.76
2470.00	-4.31	13.08%	-8.83
2480.00	-4.46	12.79%	-8.93
2490.00	-4.83	11.71%	-9.32
2500.00	-5.62	9.66%	-10.15

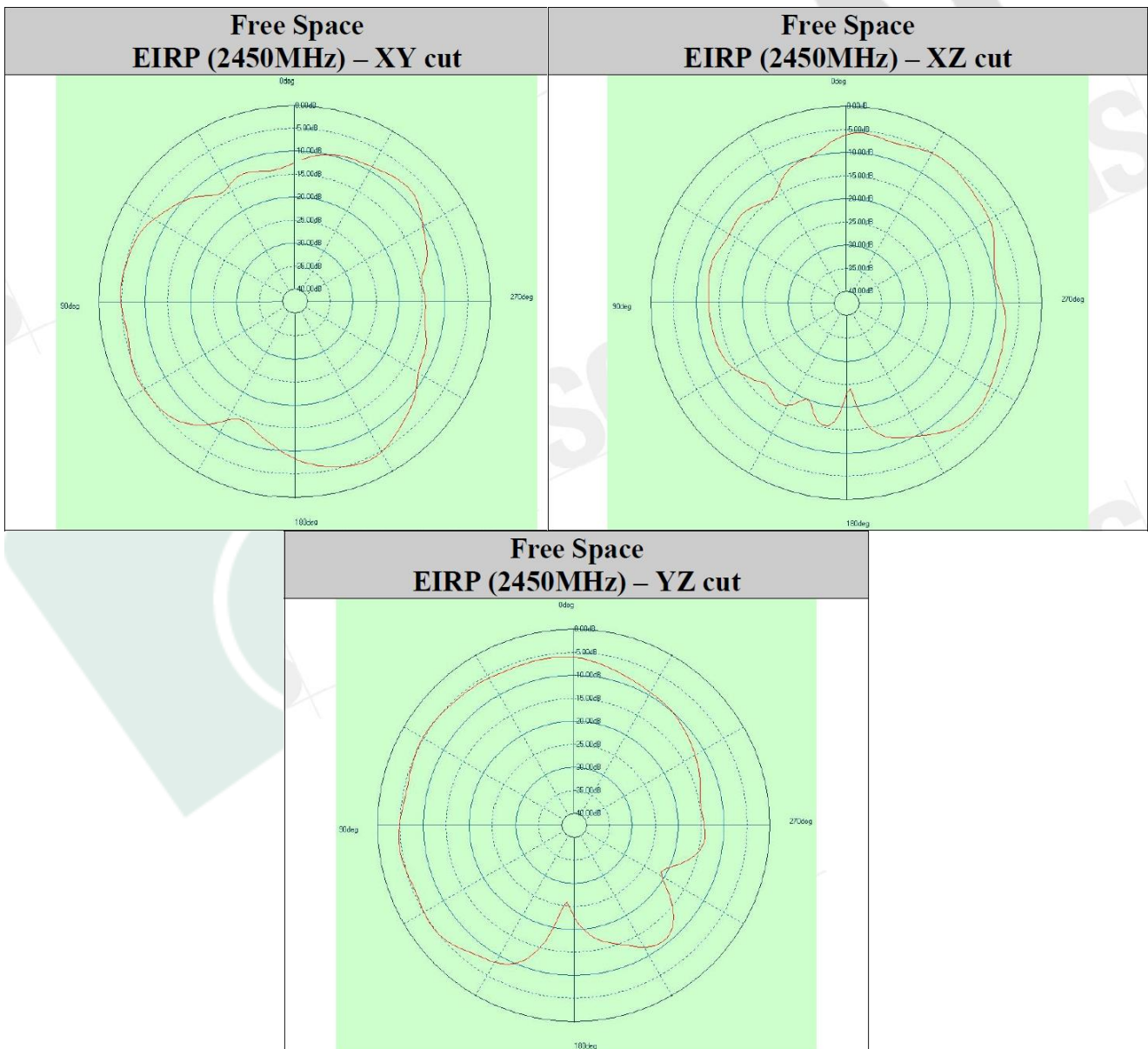

8. Reference Circuit

This chapter shows a different combination of reference circuits. **Before getting started, please read below notes carefully because it is applied to all the reference circuits.**

- 32MHz crystal is already inside the module.
- Please add L2, L3 and C14 of RF (VDD) DC/DC inductor (Reg1) when using DC-DC mode.
- Module is pre-programmed with Raytac testing code. Default is using LDO mode and need to add external 32.768khz to work.

You can use DC-DC mode *without* adding external 32.768khz, they are **NOT** related events.

- When using internal 32.768khz RC oscillator, please remove X2 / C12 / C13.

8.1. Reg0 LDO Mode

Recommend using when *the highest* input voltage is equal or greater than 3.6V. Supply power from VCC (VDDH).

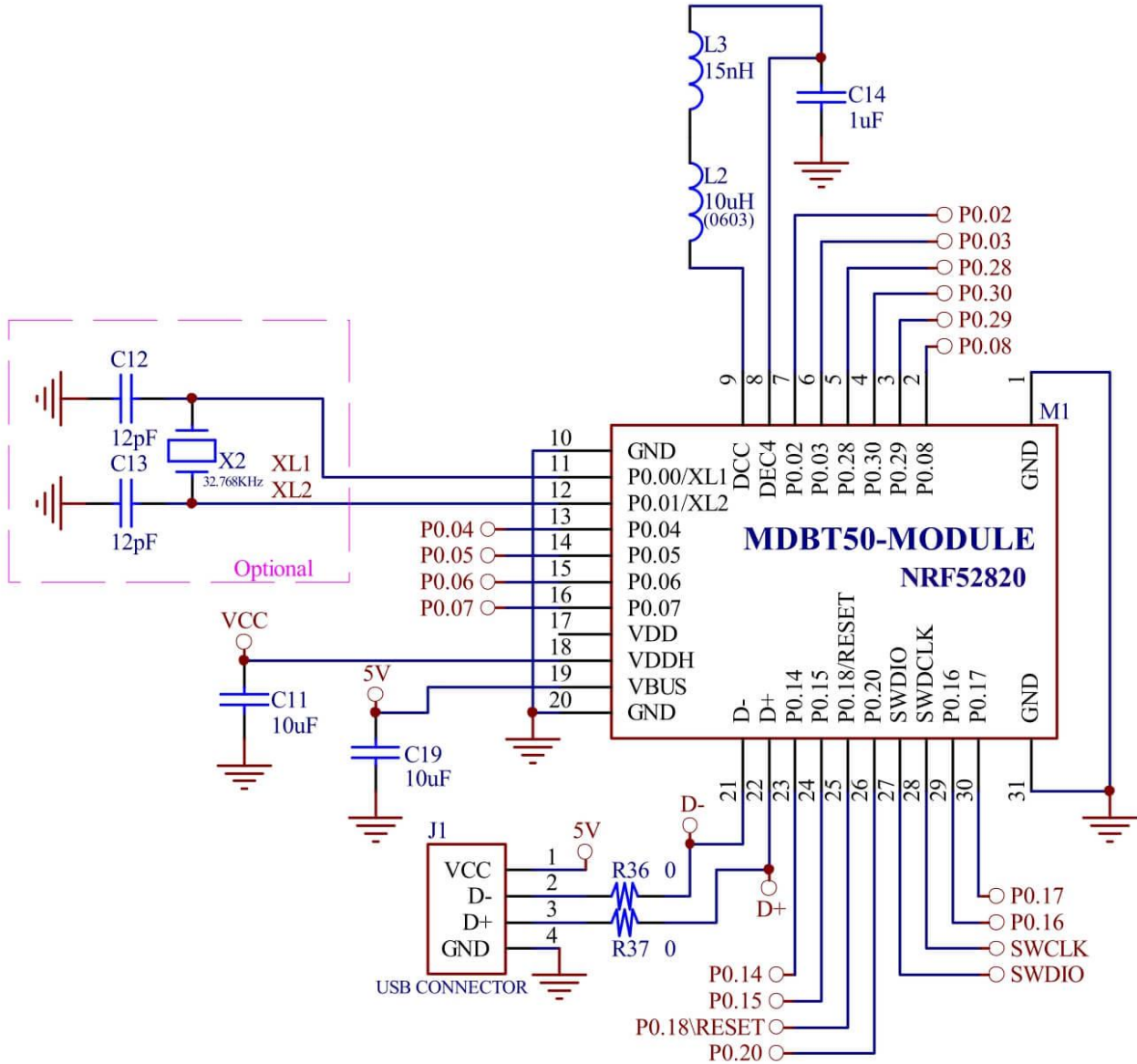

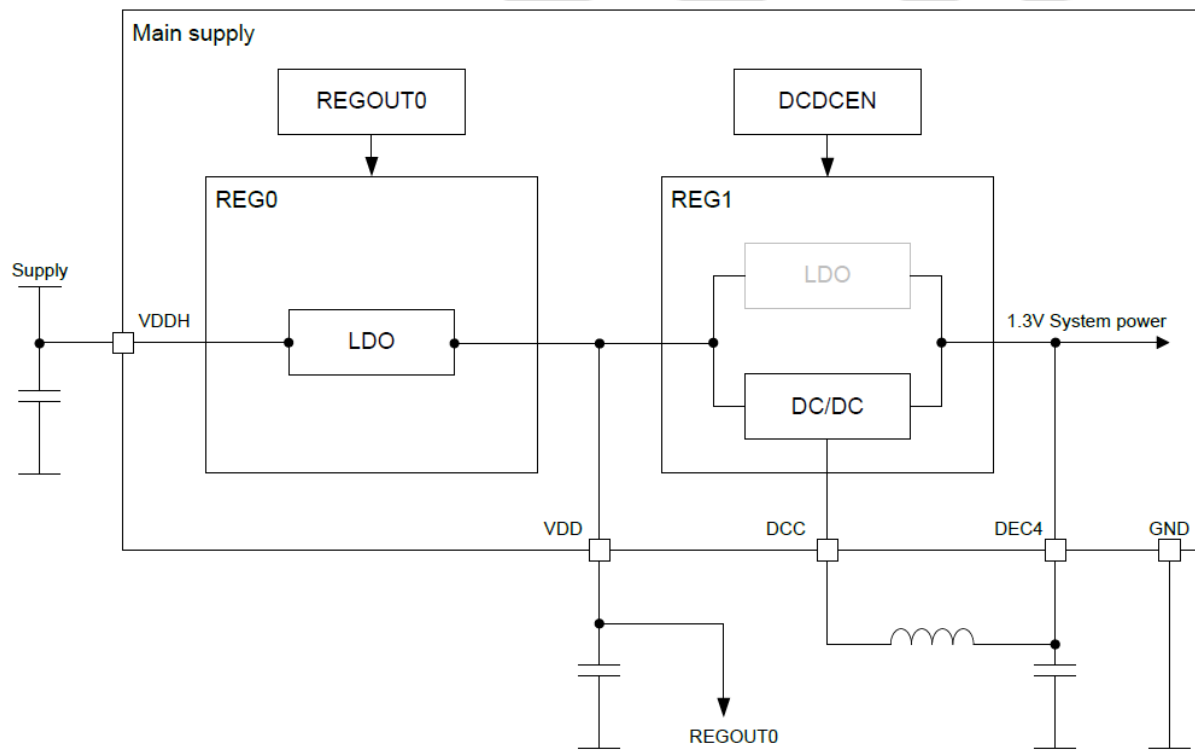
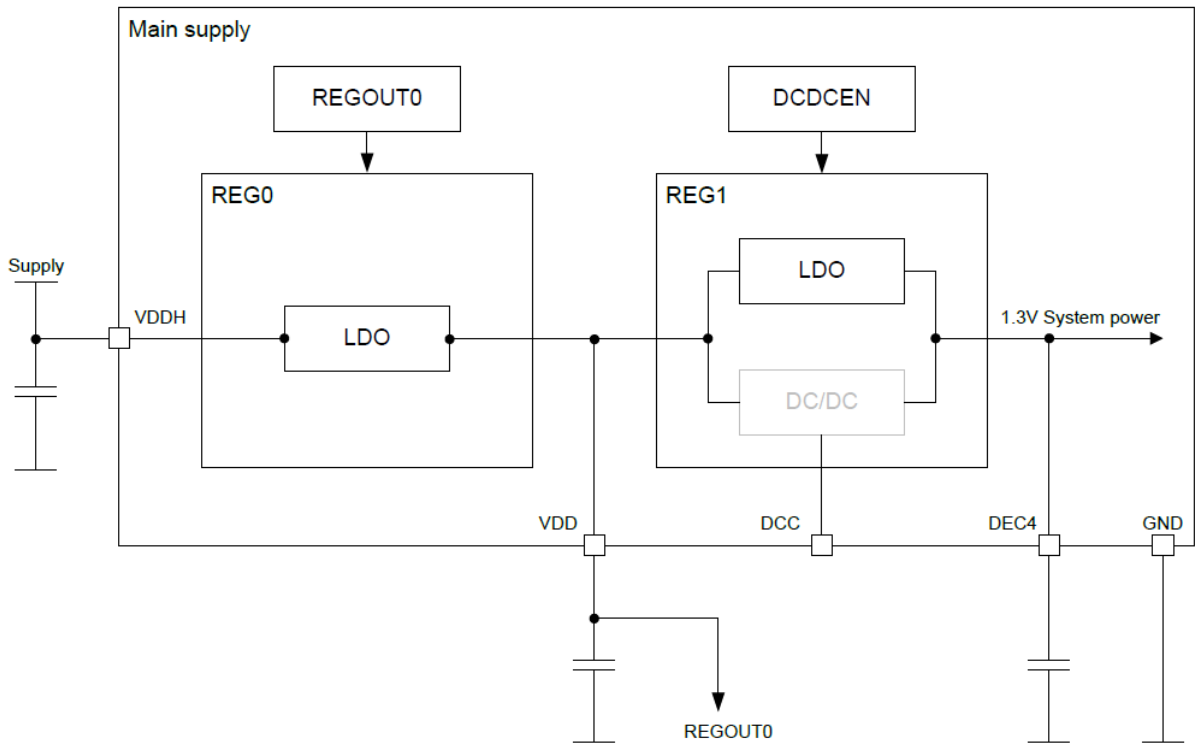

8.2. Reg0 LDO Mode Disabled

Recommend using when *the highest* input voltage is less than 3.6V.

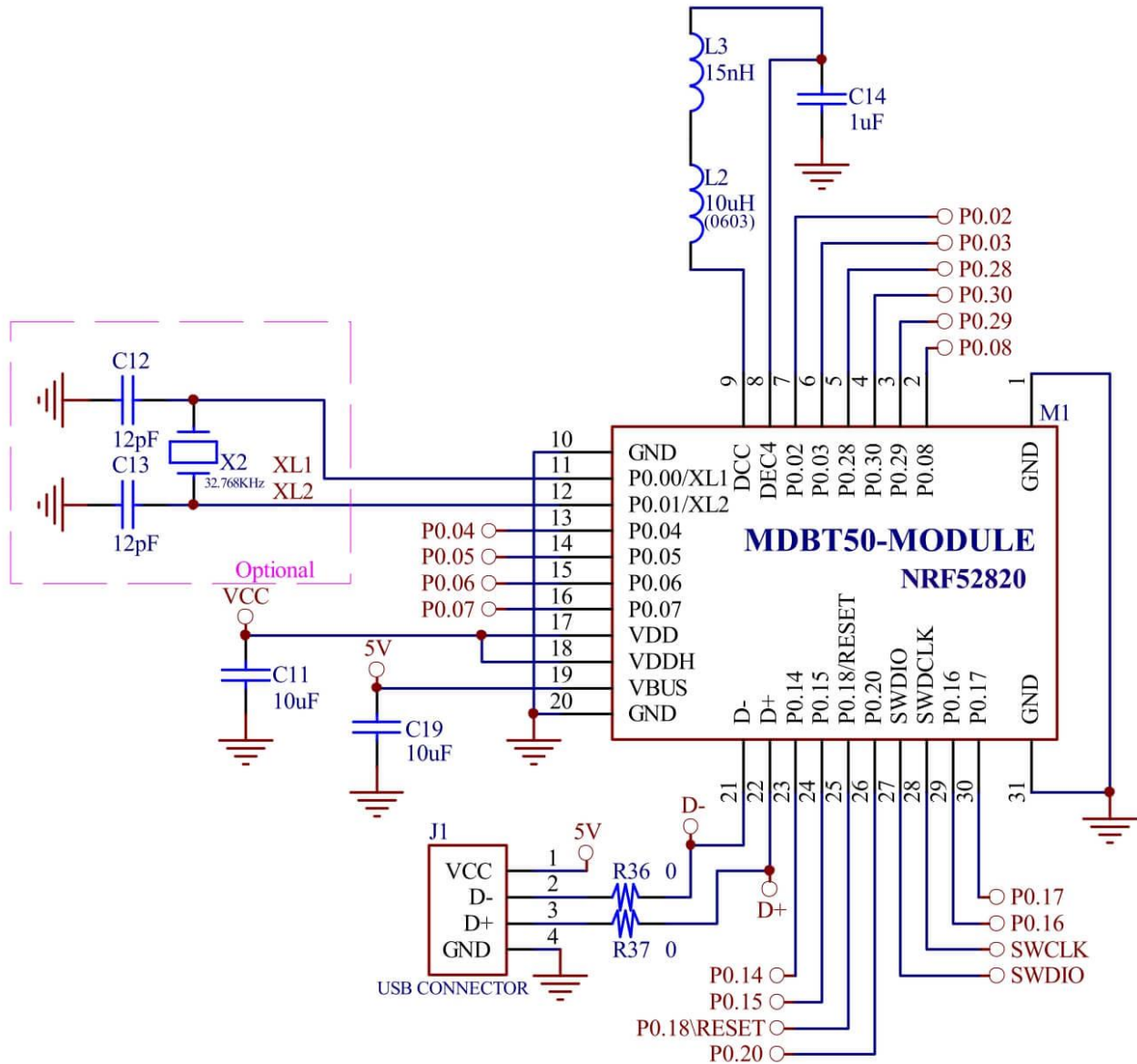

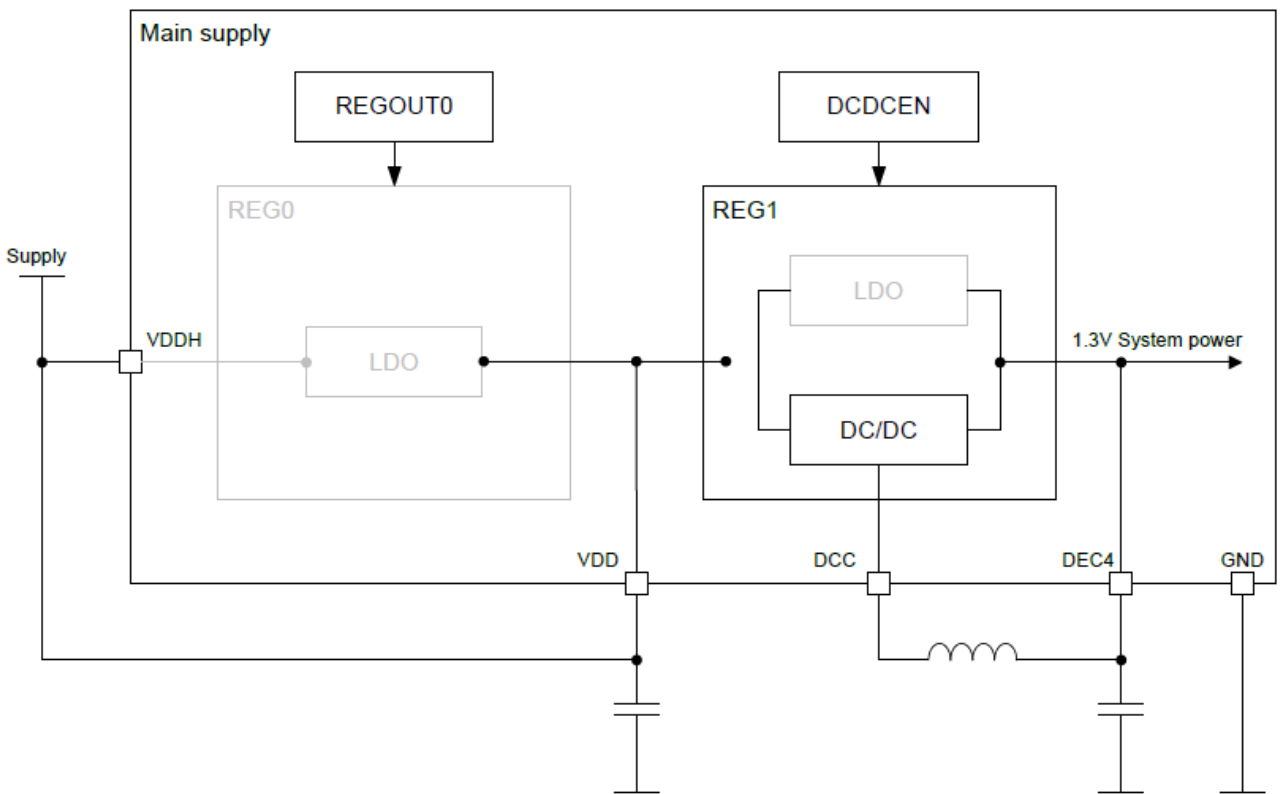
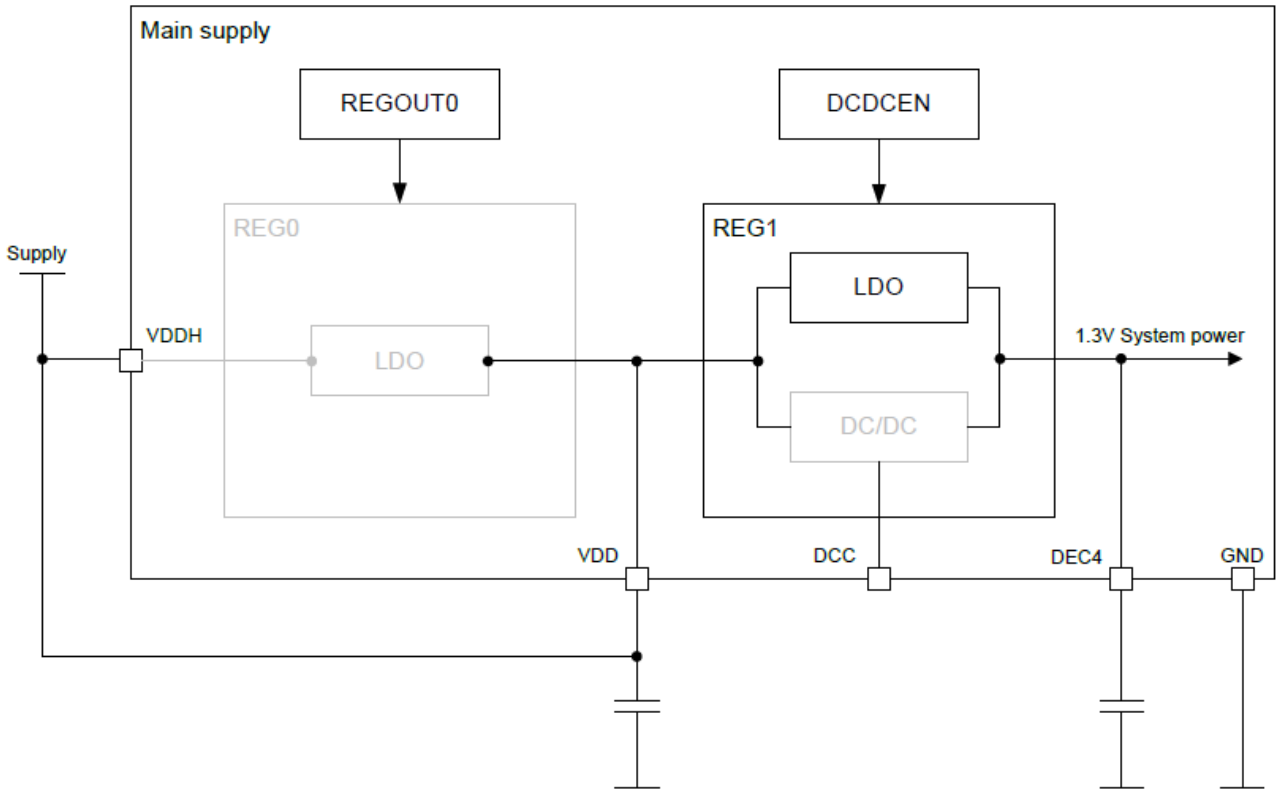

8.3. USB Powered

Recommend using when power the device via USB

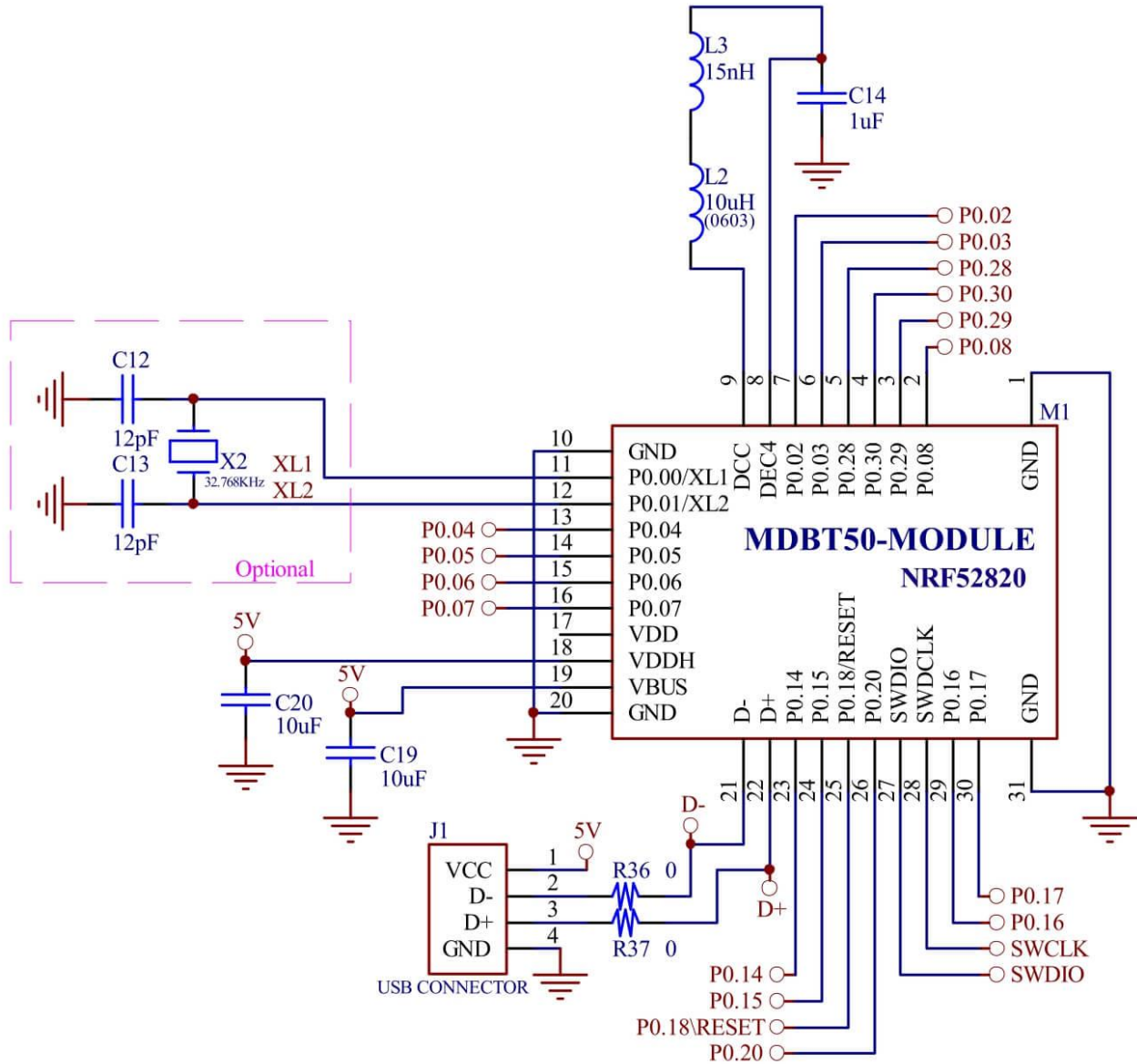

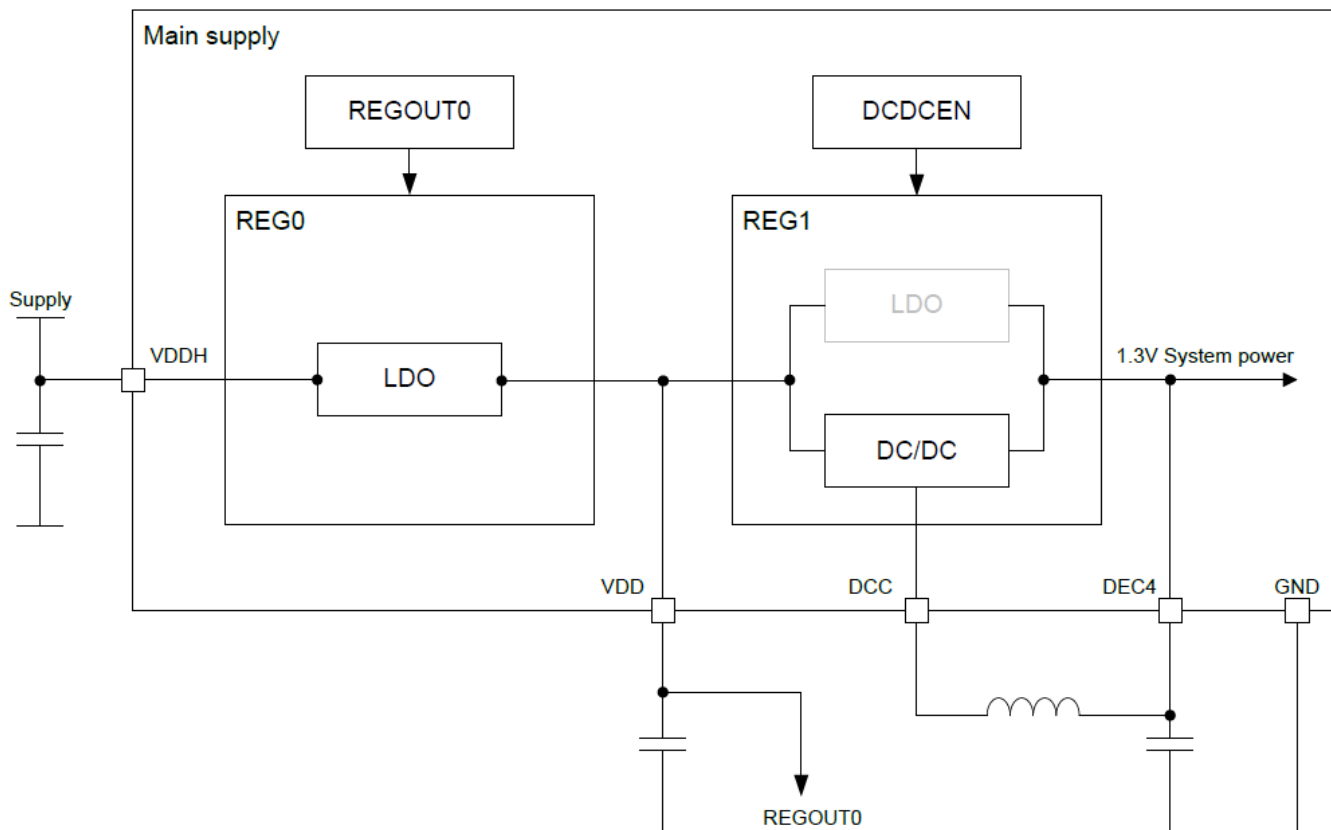
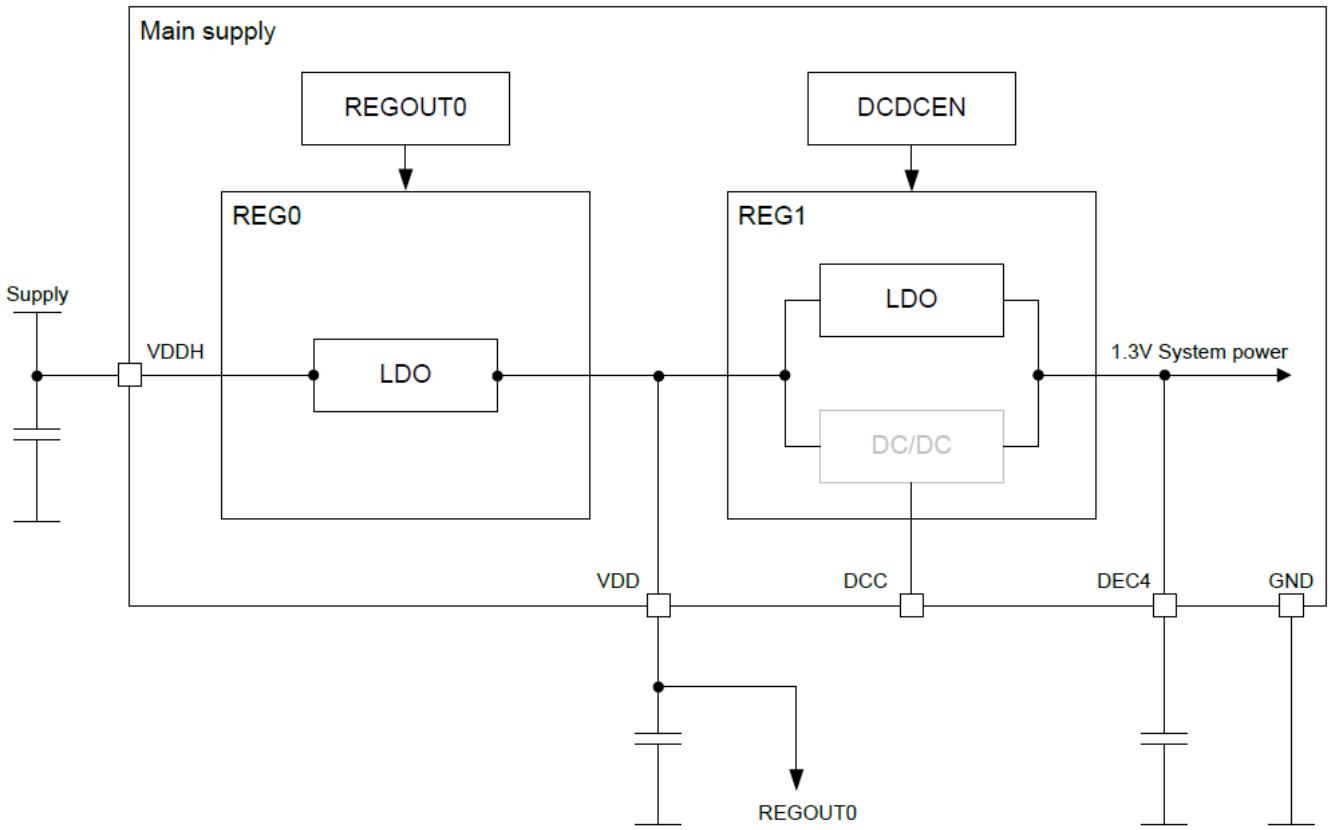

8.4. USB Disabled

This circuit only focuses on USB disabled. **Please leave D+ & D- as NC when USB is disabled.**

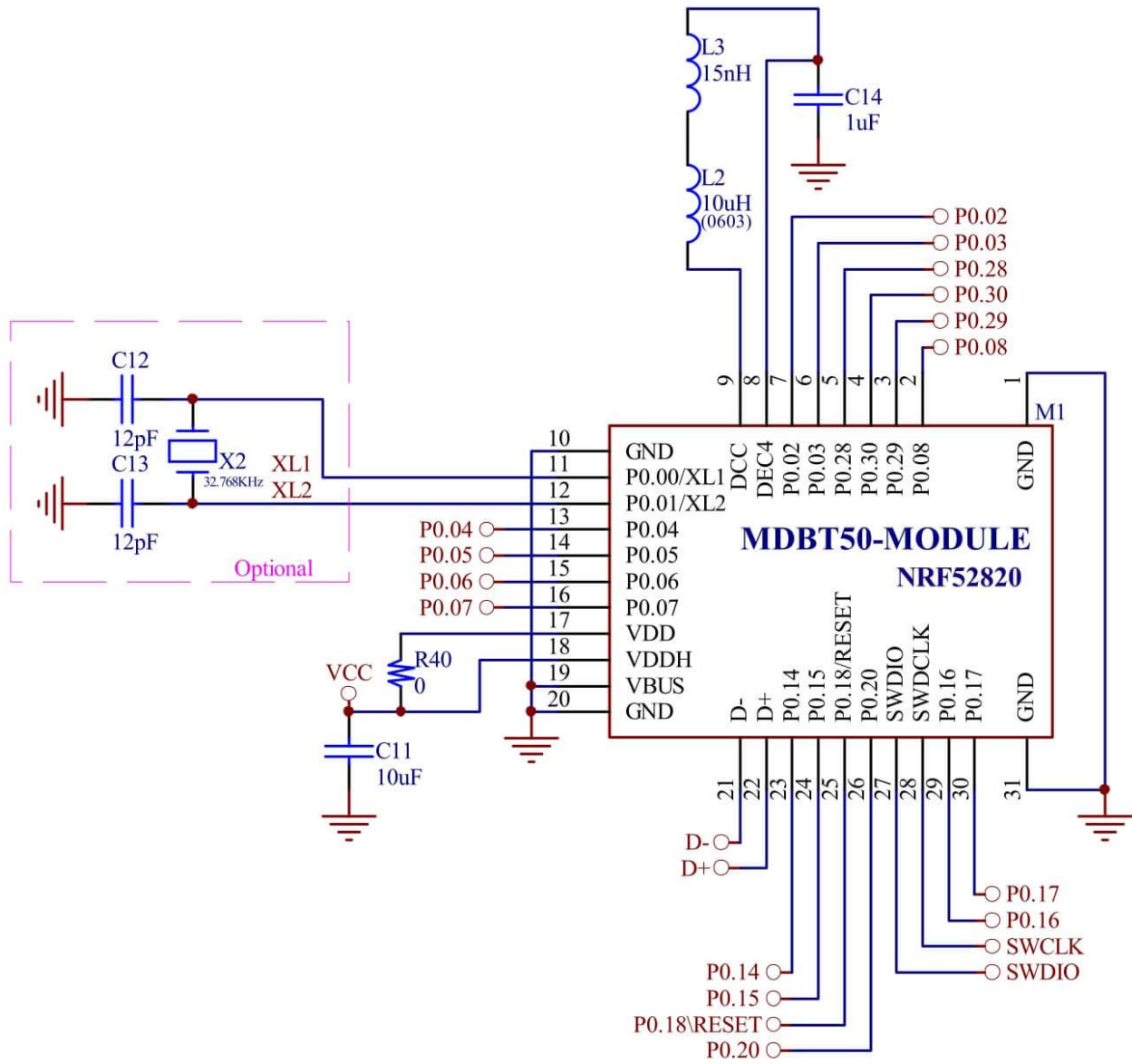

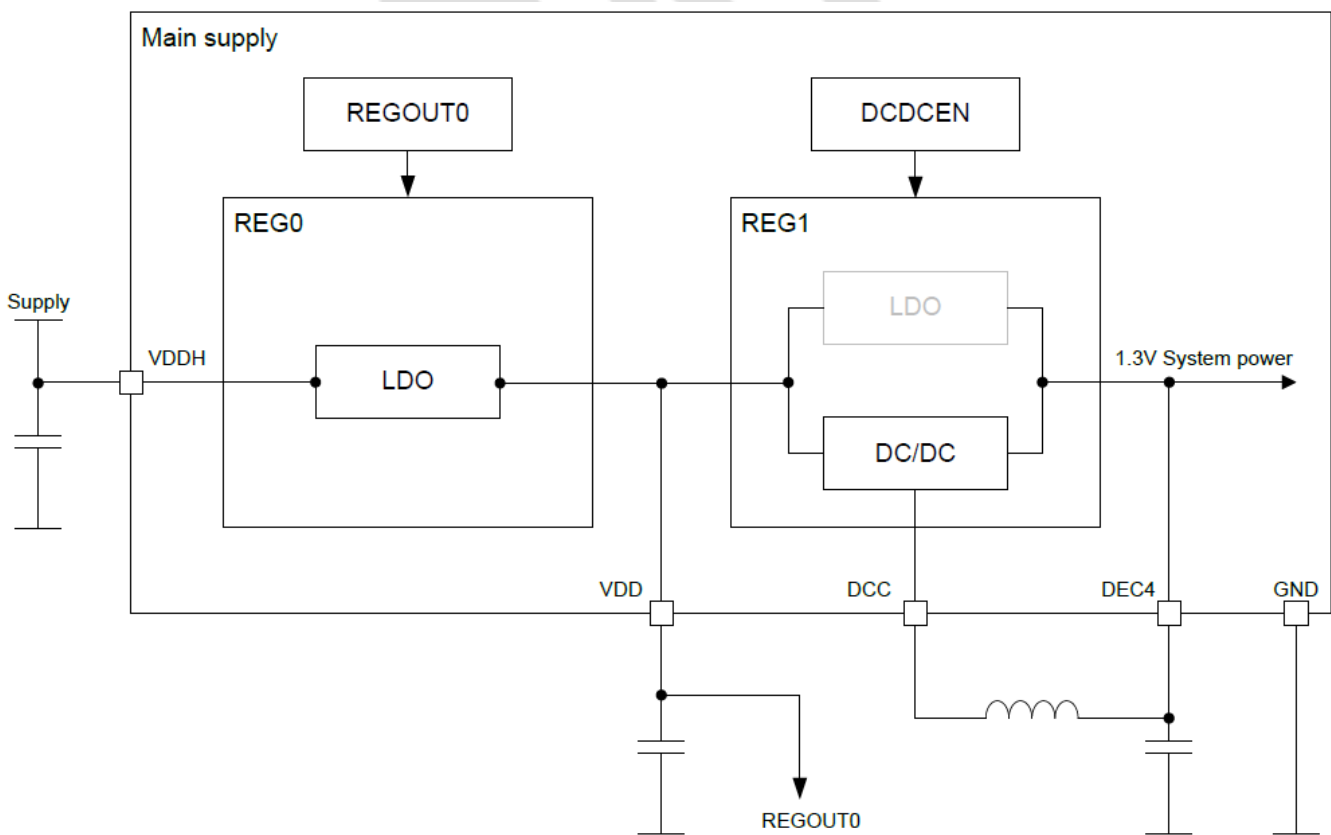
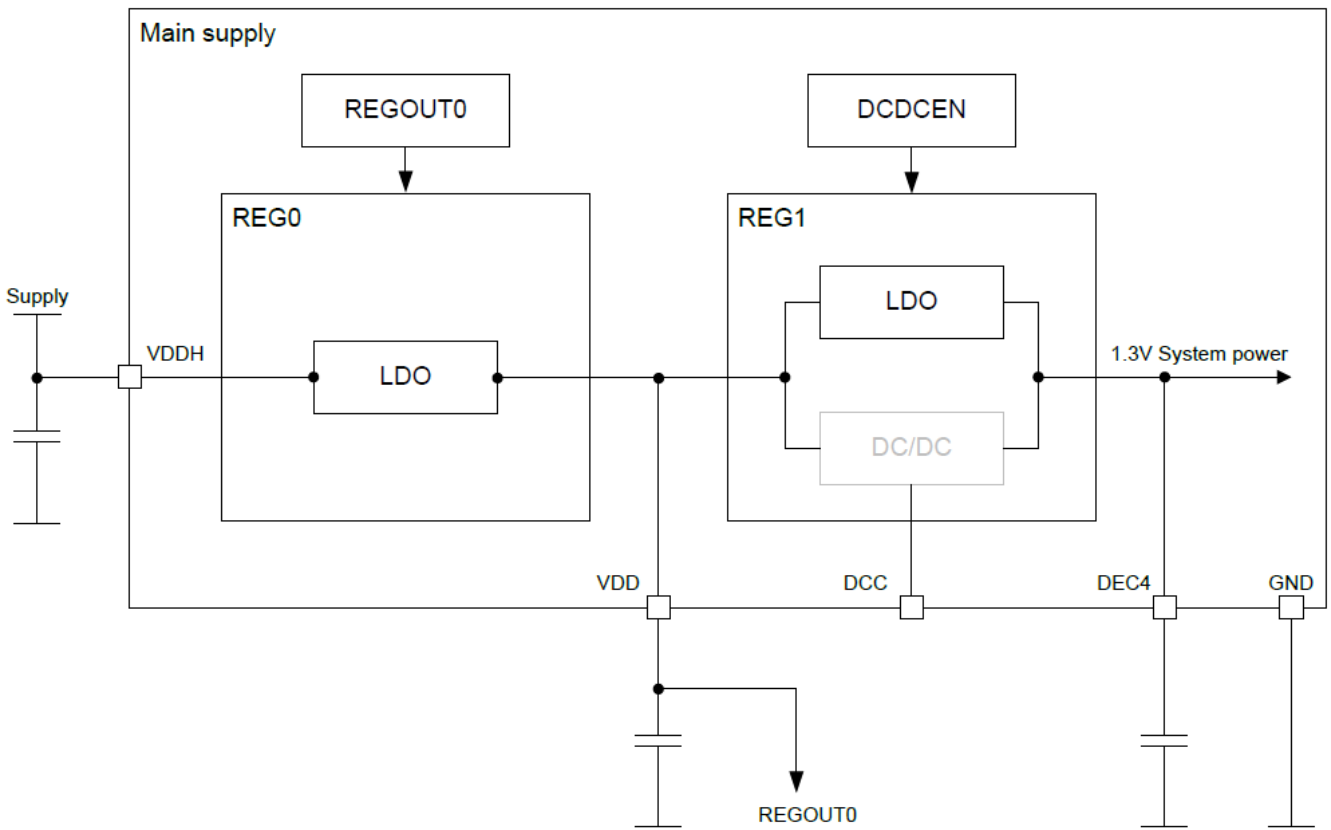

9. Certification

9.1. Declaration ID

Declaration ID	QDID(s)	Company	Specification Name
D047708	139361 - End Product	Raytac Corporation	5.1

Profile Description	Service Description
Alert Notification Profile	Alert Notification Service
Blood Pressure Profile	Blood Pressure Service
	Device Information Service
Cycling Speed & Cadence Profile	Cycling Speed & Cadence Service
	Device Information Service
Glucose Profile	Glucose Service
	Device Information Service
Health Thermometer Profile	Health Thermometer Service
	Device Information Service
Heart Rate Profile	Heart Rate Service
	Device Information Service
HID over GATT Profile	HID Service
	Battery Service
Proximity Profile	Link Loss Service
	Immediate Alert Service
	TX Power Service
Running Speed & Cadence Profile	Running Speed & Cadence Service
	Device Information Service
Time Profile	Time Profile Service
Glucose Profile (Central)	
Mesh Profile	Mesh Provisioning Service
	Mesh Proxy Service

9.2. FCC Certificate (USA)

BLE 1 Mbps & 2 Mbps

TCB	GRANT OF EQUIPMENT AUTHORIZATION Certification Issued Under the Authority of the Federal Communications Commission By:	TCB								
	SGS North America, Inc. 620 Old Peachtree Road NW Suite 100 Suwanee, GA 30024	Date of Grant: 11/17/2020 Application Dated: 11/17/2020								
Raytac Corp. 5F., No.3, Jiankang Rd., Zhonghe Dist., New Taipei City., 23586 Taiwan										
Attention: Venson Liao , R&D Manager										
NOT TRANSFERABLE EQUIPMENT AUTHORIZATION is hereby issued to the named GRANTEE, and is VALID ONLY for the equipment identified hereon for use under the Commission's Rules and Regulations listed below.										
FCC IDENTIFIER: SH6MDBT50 Name of Grantee: Raytac Corp. Equipment Class: Digital Transmission System Notes: BLE Module Modular Type: Single Modular										
<u>Grant Notes</u>	<u>FCC Rule Parts</u>	<table border="0" style="width: 100%; border-collapse: collapse;"> <thead> <tr> <th style="text-align: center; padding: 2px;">Frequency Range (MHZ)</th> <th style="text-align: center; padding: 2px;">Output Watts</th> <th style="text-align: center; padding: 2px;">Frequency Tolerance</th> <th style="text-align: center; padding: 2px;">Emission Designator</th> </tr> </thead> <tbody> <tr> <td style="text-align: center; padding: 2px;">2402.0 - 2480.0</td> <td style="text-align: center; padding: 2px;">0.0082</td> <td></td> <td></td> </tr> </tbody> </table>	Frequency Range (MHZ)	Output Watts	Frequency Tolerance	Emission Designator	2402.0 - 2480.0	0.0082		
Frequency Range (MHZ)	Output Watts	Frequency Tolerance	Emission Designator							
2402.0 - 2480.0	0.0082									
Single Modular Approval. Output power listed is conducted. Compliance of this device in all final host configurations is the responsibility of the Grantee. OEM integrators and end-users must be provided with specific operating instructions for satisfying RF exposure compliance. OEM integrators are instructed to ensure that the end user has no manual instructions to remove or install the device. This transmitter must not be co-located or operating in conjunction with any other antenna or transmitter except in accordance with FCC multi-transmitter procedures.										

9.3. TELEC Certificate (Japan)

BLE 1 Mbps & 2 Mbps

telefication bv
The Netherlands
Chamber of Commerce
51565536
www.telefication.com



Certificate
of
Radio Equipment in JAPAN
No: 201-200840 / 00

Telefication, operating as Conformity Assessment Body (CAB ID Number: 201) with respect to Japan, declares that the listed product complies with the Technical Regulations Conformity Certification of Specified Radio equipment (ordinance of MPT N° 37,1981)

Product description: BLE Module
Trademark: Raytac Corporation
Type designation: MDBT50
Serial No: N/A
Hardware / Software version: 1.0 / 1.0
Variants: See Annex 3

Manufacturer: Raytac Corp.
Address: 5F., No.3, Jiankang Road, Zhonghe District,
City: 23586 New Taipei City
Country: Taiwan

This certificate is granted to:
Name: Raytac Corp.
Address: 5F., No.3, Jiankang Road, Zhonghe District,
City: 23586 New Taipei City
Country: Taiwan

This certificate has THREE Annexes.

Zevenaar, 05 November 2020

CAB

David Chen
David Chen
Product Assessor



PRODUCTS
RvA C 224

9.4. NCC Certificate (Taiwan)

BLE 1 Mbps & 2 Mbps

MDBT50

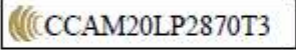
	台灣檢驗科技股份有限公司 電信管制射頻器材型式認證證明
證照字號：型式字第 AM 號	
一、申請者：	勁達國際電子有限公司
二、地址：	臺北市大安區和平東路1段145號5樓之1
三、製造廠商：	勁達國際電子有限公司
四、器材名稱：	藍牙模組
五、廠牌：	Raytac Corporation
六、型號：	MDBT50
七、發射功率(電場強度)：	詳細射頻規格如備註欄
八、工作頻率：	詳細射頻規格如備註欄
九、審驗日期：	109年11月12日
十、審驗合格標籤式樣：	
十一、警語或標示要求：	(器材本體、使用手冊、外包裝盒等應遵守下列標示要求)
1.	應於本體明顯處標示審驗合格標籤或符合性聲明標籤及其型號，並於包裝盒標示主管機關印章。最終產品應於本體明顯處標示非隨插即用射頻模組(組件)之審驗合格標籤及最終產品型號，並於包裝盒標示主管機關印章，始得販賣。
2.	依主管機關或相關技術規範規定於指定位置標示正體中文警語。
3.	經授權使用射頻模組(組件)之審驗合格標籤者，應於最終產品說明書及包裝盒提供充分與正確之資訊。
4.	於網際網路販賣電信管制射頻器材者，應於該網際網路網頁標示其型號及審驗合格標籤或符合性聲明標籤資訊。但最終產品得僅標示其型號及其組裝之非隨插即用射頻模組(組件)之審驗合格標籤資訊。
5.	使用手冊應標示下列資訊： (1) 取得審驗證明之低功率射頻器材，非經核准，公司、商號或使用者均不得擅自變更頻率、加大功率或變更原設計之特性及功能。低功率射頻器材之使用不得影響飛航安全及干擾合法通信；經發現有干擾現象時，應立即停用，並改善至無干擾時方得繼續使用。前述合法通信，指依電信管理法規定作業之無線電通信。低功率射頻器材須忍受合法通信或工業、科學及醫療用電波輻射性電機設備之干擾。

台灣檢驗
科技股份有限公司
電信設備
審驗印章

型式認證號碼：CCAM20LP2870T3 第 1 頁，共 2 頁 本證書與續頁分開使用無效

BLE 1 Mbps & 2 Mbps

MDBT50-P

台灣檢驗科技股份有限公司
電信管制射頻器材型式認證證明

證照字號：型式字第 AM 號

- 一、申請者：勁達國際電子有限公司
- 二、地址：臺北市大安區和平東路1段145號5樓之1
- 三、製造廠商：勁達國際電子有限公司
- 四、器材名稱：藍牙模組
- 五、廠牌：Raytac Corporation
- 六、型號：MDBT50-P
- 七、發射功率(電場強度)：詳細射頻規格如備註欄
- 八、工作頻率：詳細射頻規格如備註欄
- 九、審驗日期：109年11月12日

十、審驗合格標籤式樣：

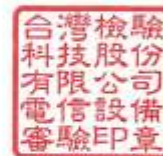
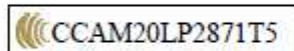

十一、警語或標示要求：(器材本體、使用手冊、外包裝盒等應遵守下列標示要求)

1. 應於本體明顯處標示審驗合格標籤或符合性聲明標籤及其型號，並於包裝盒標示主管機關印章。最終產品應於本體明顯處標示非隨插即用射頻模組(組件)之審驗合格標籤及最終產品型號，並於包裝盒標示主管機關印章，始得販賣。
2. 依主管機關或相關技術規範規定於指定位置標示正體中文警語。
3. 經授權使用射頻模組(組件)之審驗合格標籤者，應於最終產品說明書及包裝盒提供充分與正確之資訊。
4. 於網際網路販賣電信管制射頻器材者，應於該網際網路網頁標示其型號及審驗合格標籤或符合性聲明標籤資訊。但最終產品得僅標示其型號及其組裝之非隨插即用射頻模組(組件)之審驗合格標籤資訊。
5. 使用手冊應標示下列資訊：
 - (1) 取得審驗證明之低功率射頻器材，非經核准，公司、商號或使用者均不得擅自變更頻率、加大功率或變更原設計之特性及功能。低功率射頻器材之使用不得影響飛航安全及干擾合法通信；經發現有干擾現象時，應立即停用，並改善至無干擾時方得繼續使用。前述合法通信，指依電信管理法規定作業之無線電通信。低功率射頻器材須忍受合法通信或工業、科學及醫療用電波輻射性電機設備之干擾。

9.5. CE (EU) & RCM (Australia & New Zealand) Test Report

BLE 1 Mbps & 2 Mbps



Report No.: T200824W10-RT

Page: 4 / 58
Rev.: 00

1. TEST RESULT CERTIFICATION

Applicant: Raytac Corp.
5F, No.3, Jiankang Road, Zhonghe District, New Taipei City
23586, Taiwan

Manufacturer: Raytac Corp.
5F, No.3, Jiankang Road, Zhonghe District, New Taipei City
23586, Taiwan

Equipment Under Test: BLE Module

Trade Name: Raytac Corporation

Model Number: MDBT50, MDBT50-P

Date of Test: August 26 ~ September 2, 2020

APPLICABLE STANDARDS	
STANDARD	TEST RESULT
ETSI EN 300 328 V2.2.2: 2019 & AS/NZS 4268:2017	No non-compliance noted
Statements of Conformity	
Determination of compliance is based on the results of the compliance measurement, not taking into account measurement instrumentation uncertainty.	

The above equipment was tested by Compliance Certification Services Inc. for compliance with the requirements set forth in ETSI EN 300 328. The results of testing in this report apply only to the product/system, which was tested. Other similar equipment will not necessarily produce the same results due to production tolerance and measurement uncertainties.

Approved by:

Kevin Tsai
Deputy Manager

VERIFICATION OF COMPLIANCE

Issue Date: Sep. 11, 2020
Applicant: Raytac Corporation
Address: 5F., No.3, Jiankang Road, Zhonghe District, New Taipei City, Taiwan
Manufacturer: Raytac Corporation
Address: 5F., No.3, Jiankang Road, Zhonghe District, New Taipei City 23586, Taiwan

Contact Information: Web: www.raytac.com
TEL#: +886-2-3234-0208
E-mail#: service@raytac.com

Product: BLE Module
Brand Name/Trade Mark: Raytac Corporation
Model/Type: MDBT50
Added Model(s): MDBT50-P
Applicable Standards: EN 301 489 –1 v2.2.3 : 2019-11
EN 301 489 –17 v3.2.2 : 2019-12 (Draft)
EN 55032 : 2015+AC:2016-07
EN 61000-4-2 : 2009
EN 61000-4-3 : 2006+A1:2008+A2:2010

Test Laboratory: SGS Taiwan Ltd.
Electromagnetic Compatibility Laboratory
No.2, Keji 1st Rd., Guishan District, Taoyuan City, Taiwan

Test Report No.: MH/2020/80014, dated on Sep. 11, 2020

Conclusion: Based upon a review of the Test Report(s), the tested sample of the product mentioned above is deemed to comply with the requirements of the above standards.

Note: This verification is only valid for the product and configuration described and in conjunction with the test report as detailed above.

Authorised Signatory:



SGS Taiwan Ltd.
Eddy Cheng
Assistant Supervisor

9.6. IC Certificate (Canada)

BLE 1 Mbps & 2 Mbps

SGS

Certificate	US0186.2020.000409
SGS Reference	CCS-CERT201100040-02
Certified Product	BLE Module
ISED ID Number	8017A-MDBT50
Type of Equipment	Bluetooth device
Certificate Holder	Raytac Corp.
Address	5F, No.3, Jianshang Road, New Taipei City 23586 Taiwan

Certification of equipment means only that the equipment has met the requirements of the above-noted specification. Licence applications, where applicable to use certified equipment, are acted on accordingly by the Industry Canada issuing office and will depend on the existing radio environment, service and location of operation. This certificate is issued on condition that the holder complies and will continue to comply with the requirements and procedures issued by Industry Canada. The equipment for which this certificate is issued shall not be manufactured, imported, distributed, leased, offered for sale or sold unless the equipment complies with the applicable technical specifications and procedures issued by Industry Canada.

I hereby attest that the subject equipment was tested and found in compliance with the above-noted specification.

La certification du matériel signifie seulement que le matériel a satisfait aux exigences de la norme indiquée ci-dessus. Les demandes de licences nécessaires pour l'utilisation du matériel certifié sont traitées en conséquence par le bureau de délivrance d'Industrie Canada et dépendent des conditions radio ambiantes, du service et de l'emplacement d'exploitation. Le présent certificat est délivré à la condition que le titulaire satisfasse et continue de satisfaire aux exigences et aux procédures d'Industrie Canada. Le matériel à l'égard duquel le présent certificat est délivré ne doit pas être fabriqué, importé, distribué, loué, mis en vente ou vendu à moins d'être conforme aux procédures et aux spécifications techniques applicables publiées par Industrie Canada.

J'atteste par la présente que le matériel a fait l'objet d'essai et jugé conforme à la spécification ci-dessus.

Authorized By	Date Issued
	11/02/2020
Sen. Lv Certifier	US0186

This Certificate is valid only with a concurrent listing with Industry Canada Radio Listing (REL).

SGS North America, Inc.
 620 Old Peachtree Road, Ste. 100, Suwanee, GA 30024, USA
 t +1 770 570 1800 f +1 770 277 1240 www.sgs.com
 Page 1 of 2

EQUIPMENT DETAIL				
Frequency Range (MHz)	RF Power (Watts)	Antenna Type	Necessary Bandwidth(kHz)	Emission Classification
2402.0-2480.0	0.0082	Note 1	2005.7	F1D
Notes 1) Chip antenna: -3.05dBi, PCB Antenna: -3.24dBi				
SPECIFICATION				
Standard/Specification	Issue		Issue Date	
RSS-247	Issue 2		February 2017	

9.7. SRRC Certificate (China)

BLE 1 Mbps & 2 Mbps

无线电发射设备
Radio Transmission Equipment
型号核准证
Type Approval Certificate

劲达国际电子有限公司 (台湾):

根据《中华人民共和国无线电管理条例》
In accordance with the provisions on the Radio
Regulations of the People's Republic of China, the following
符合中华人民共和国无线电管理规定和
radio transmission equipment, after examination, conforms
技术标准, 其核准代码为: CMIIT ID: 2020DJ11240
to the provisions with its CMIIT ID:

有效期: 五年
Validity

(发证机关)
Sealed by Issuing authority
2020年 09月30日
Year Month Date

9.8. KC Certificate (South Korea)

BLE 1 Mbps & 2 Mbps

3078-F176-AFFB-BB25

방송통신기자재등의 적합인증서 <i>Certificate of Broadcasting and Communication Equipments</i>	
상호 또는 성명 <i>Trade Name or Applicant</i>	Raytac Corporation
기자재명칭(명칭) <i>Equipment Name</i>	특정소출력 무선기기(무선데이터통신시스템용 무선기기)
기본모델명 <i>Basic Model Number</i>	MDBT50
파생모델명 <i>Series Model Number</i>	MDBT50-P
인증번호 <i>Certification No.</i>	R-C-ryt-MDBT50
제조사/제조국가 <i>Manufacturer/ Country of Origin</i>	Raytac Corporation / 대만
인증연월일 <i>Date of Certification</i>	2020-09-14
기타 <i>Others</i>	
<p>위 기자재는 「전파법」 제58조의2 제2항에 따라 인증되었음을 증명합니다. It is verified that foregoing equipment has been certificated under the Clause 2, Article 58-2 of Radio Waves Act.</p> <p style="text-align: right;">2020년(Year) 09월(Month) 14일(Day)</p> <p style="text-align: center;">국립전파연구원장 </p> <p style="text-align: center;"><i>Director General of National Radio Research Agency</i></p> <p>※ 인증받은 방송통신기자재는 반드시 "적합성평가표시" 를 부착하여 유통하여야 합니다. 위반시 과태료 처분 및 인증이 취소될 수 있습니다.</p>	

9.9. RoHS & REACH Report

Please visit "[Support](#)" page of our website to download.

9.10. End-Product Label

It is suggested using following content adding to package or user manual or label to obey the regulation. Any rules of end-product label shall refer to each regulation for final reference.

9.10.1. FCC (USA)

The FCC statement should be included in the user manual when there is no enough space on label. Otherwise, it should be included on the label.

"This device complies with part 15 of the FCC rules. Operation is subject to the following two conditions. (1) This device may not cause harmful interference. (2) This device must accept any interference received, including interference that may cause undesired operation."

The final end product must be labeled in a visible area with the following: "Contain FCC ID: SH6MDBT50".

9.10.2. TELEC (Japan)

When manufacturer is placing the product on the Japanese market, the product must be affixed with the following Specified Radio Equipment marking:

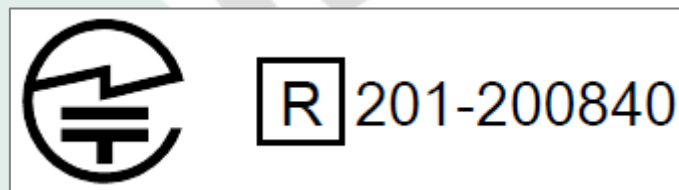

9.10.3. NCC (Taiwan)

請依下列標籤式樣自製標籤，標貼或印鑄於器材本體明顯處，始得販賣或公開陳列。

MDBT50 Series

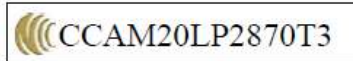

MDBT50-P Series

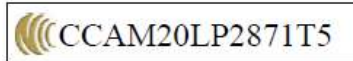

平台廠商必須於平台上標示字樣「本產品內含射頻模組：ID 編號 CCAM20LP2870T3」或「本產品內含射頻模組：ID 編號 CCAM20LP2871T5」。

「平台」定義如下：若器材組裝本案模組，消費者仍能正常使用該器材主要功能，該器材得視為平台。若器材不組裝本案模組，消費者不能正常使用該器材主要功能，該器材不能視為平台。該類不同廠牌型號器材組裝本案審驗模組後，須分別申請型式認證。

9.10.4. IC (Canada)

The IC statement should be included in the user manual when there is no enough space on label. Otherwise, it should be included on the label.

“This device complies with Industry Canada license-exempt RSS Standard(s). Operation is subject to the following two conditions. (1) This device may not cause harmful interference. (2) This device must accept any interference received, including interference that may cause undesired operation.

Le présent appareil est conforme aux CNR d'Industrie Canada applicables aux appareils radio exempts de licence. L'exploitation est autorisée aux deux conditions suivantes: (1) l'appareil ne doit pas produire de brouillage, et (2) l'utilisateur de l'appareil doit accepter tout brouillage radioélectrique subi, même si le brouillage est susceptible d'en compromettre le fonctionnement.”

The final end product must be labeled in a visible area with the following: “Contain IC ID: 8017A-MDBT50”.

10. Notes and Cautions

Module is not designed to last for a lifetime. Like general products, it is expected to be worn out after continuous usage through the years. To assure that product will perform better and last longer, please make sure you:

- Follow the guidelines of this document while designing circuit/end-product. Any discrepancy of core Bluetooth technology and technical specification of IC should refer to definition of Bluetooth Organization and Nordic Semiconductor as final reference.
- Do not supply voltage that is not within range of specification.
- Eliminate static electricity at any cost when working with the module as it may cause damage. It is highly recommended adding anti-ESD components to circuit design to prevent damage from real-life ESD events. Anti-ESD methods can be also applied in mechanical design.
- Do not expose modules under direct sunlight for long duration. Modules should be kept away from humid and salty air conditions, and any corrosive gasses or substances. Store it within -40°C to $+125^{\circ}\text{C}$ before and after installation.
- Avoid any physical shock, intense stress to the module or its surface.
- Do not wash the module. No-Clean Paste is used in production. Washing it will oxidize the metal shield and have chemistry reaction with No-Clean Paste. Functions of the module are not guaranteed if it has been washed.

The module is not suitable for life support device or system and not allowed to be used in destructive device or systems in any direct or indirect ways. The customer agrees to indemnify Raytac for any losses when applying modules in applications such as the ones described above.

11. Basic Facts for nRF52 Family

Below chart shows basic spec for Nordic nRF52 family, which is helpful to understand the differences between each SoC. Any discrepancy shall refer to Nordic's technical document as final reference.

See [Full List of Raytac's BLE Modules](#) for complete model no. of each item.

Nordic Solution	nRF52840	nRF52833	nRF52820	nRF52832	nRF52810	nRF52811	nRF52805
RAYTAC Model No. (MDBTXX)	50Q series	50Q series 50 series	50 series	42Q series 42 series 42V series	42Q series	42Q Series	42T series 42TV series
Bluetooth Direction Finding		V	V			V	
Bluetooth 5 Long Range (125kbps)	V	V	V			V	
Bluetooth 5 High Speed	V	V	V	V	V	V	V
Bluetooth 5 Ad. Extention (x8)	V	V	V	V	V	V	V
Flash (kBytes)	1024	512	256	512	192	192	192
RAM (kBytes)	256	128	32	64	24	24	24
ANT Plus	V	V	V	V	V	V	
IEEE 802.15.4	V	V	V			V	
ARM® TrustZone® Cryptocell	V						
USB	V	V	V				
QSPI	V						
NFC	V	V		V			
I2S	V	V		V			
SPI, TWI, UART, PWM	V	V	V	V	V	V	without PWM
PDM	V	V		V	V	V	
ADC, Comparators	V	V	without ADC	V	V	V	without comparators
Supply Range (V)	1.7 to 5.5	1.7 to 5.5	1.7 to 5.5	1.7 to 3.6	1.7 to 3.6	1.7 to 3.6	1.7 to 3.6

12. Useful Links

- Nordic Infocenter: <https://infocenter.nordicsemi.com/index.jsp>
All the necessary technical files and software development kits of Nordic's chip are on this website.
- Nordic DevZone: <https://devzone.nordicsemi.com/questions/>
A highly recommended website for firmware developer. Interact, discuss and consult with other fellow developers and Nordic's employees to get answers to your questions. The site also includes tutorials in detail to help you get started.
- Official Page of nRF52820 : <https://www.nordicsemi.com/Products/Low-power-short-range-wireless/nRF52820>
A brief introduction to nRF52820 and download links for Nordic's developing software and SoftDevices.

Full List of Raytac's BLE Modules

● MDBT40 Series

Series	Nordic Solution	Raytac No.	IC Ver.	Antenna	RAM	Flash Memory
MDBT40	nRF51822	MDBT40-256V3	3	Chip Antenna	16 kb	256 K
		MDBT40-256RV3			32 kb	256 K
MDBT40-P	nRF51822	MDBT40-P256V3	3	PCB Antenna	16 kb	256 K
		MDBT40-P256RV3			32 kb	256 K

● MDBT42Q Series (QFN Package IC)

Series	Nordic Solution	Raytac No.	IC Ver.	Antenna	RAM	Flash Memory
MDBT42Q	nRF52832	MDBT42Q-512KV2	2	Chip Antenna	64 kb	512 K
	nRF52810	MDBT42Q-192KV2	2		24 kb	192 K
	nRF52811	MDBT42Q-192KL	1			
MDBT42Q-P	nRF52832	MDBT42Q-P512KV2	2	PCB Antenna	64 kb	512 K
	nRF52810	MDBT42Q-P192KV2	2		24 kb	192 K
	nRF52811	MDBT42Q-P192KL	1			
MDBT42Q-U	nRF52832	MDBT42Q-U512KV2	2	u.FL Connector	64 kb	512 K

● MDBT42 Series (WLCSP Package IC)

Series	Nordic Solution	Raytac No.	IC Ver.	Antenna	RAM	Flash Memory
MDBT42	nRF52832	MDBT42-512KV2	2	Chip Antenna	64 kb	512 K
MDBT42-P		MDBT42-P512KV2		PCB Antenna		

● MDBT42V Series (WLCSP Package IC)

Series	Nordic Solution	Raytac No.	IC Ver.	Antenna	RAM	Flash Memory
MDBT42V	nRF52832	MDBT42V-512KV2	2	Chip Antenna	64 kb	512 K
MDBT42V-P		MDBT42V-P512KV2		PCB Antenna		

● MDBT42T Series (WLCSP Package IC)

Series	Nordic Solution	Raytac No.	IC Ver.	Antenna	RAM	Flash Memory
MDBT42T	nRF52805	MDBT42T-192K	1	Chip Antenna	24 kb	192 K
MDBT42T-P		MDBT42T-P192K		PCB Antenna		

● MDBT42TV Series (WLCSP Package IC)

Series	Nordic Solution	Raytac No.	IC Ver.	Antenna	RAM	Flash Memory
MDBT42TV	nRF52805	MDBT42TV-192K	1	Chip Antenna	24 kb	192 K
MDBT42TV-P		MDBT42TV-P192K		PCB Antenna		

● MDBT50Q Series (aQFN Package IC)

Series	Nordic Solution	Raytac No.	IC Ver.	Antenna	RAM	Flash Memory
MDBT50Q	nRF52840	MDBT50Q-1MV2	2	Chip Antenna	256 kb	1 MB
	nRF52833	MDBT50Q-512K	1		128 kb	512 kb
MDBT50Q-P	nRF52840	MDBT50Q-P1MV2	2	PCB Antenna	256 kb	1 MB
	nRF52833	MDBT50Q-P512K	1		128 kb	512 kb
MDBT50Q-U	nRF52840	MDBT50Q-U1MV2	2	u.FL Connector	256 kb	1 MB
	nRF52833	MDBT50Q-U512K	1		128 kb	512 kb
Dongle	nRF52840	MDBT50Q-RX	1, 2	PCB Antenna	256 kb	1 MB

● MDBT50 Series (QFN Package IC)

Series	Nordic Solution	Raytac No.	IC Ver.	Antenna	RAM	Flash Memory
MDBT50	nRF52820	MDBT50-256R	1	Chip Antenna	32 kb	256 kb
	nRF52833	MDBT50-512K	1		128 kb	512 kb
MDBT50-P	nRF52820	MDBT50-P256R	1	PCB Antenna	32 kb	256 kb
	nRF52833	MDBT50-P512K	1		128 kb	512 kb

● **MDBT53 Series (WLCSP Package IC)**

Series	Nordic Solution	Raytac No.	IC Ver.	Antenna	RAM	Flash Memory
MDBT53	nRF5340	MDBT53-1M	1	Chip Antenna	512 kb	1 MB
MDBT53-P	nRF5340	MDBT53-P1M	1	PCB Antenna	512 kb	1 MB
MDBT53-U	nRF5340	MDBT53-U1M	1	u.FL Connector	512 kb	1 MB

● **MDBT53V Series (WLCSP Package IC)**

Series	Nordic Solution	Raytac No.	IC Ver.	Antenna	RAM	Flash Memory
MDBT53V	nRF5340	MDBT53V-1M	1	Chip Antenna	512 kb	1 MB
MDBT53V-P	nRF5340	MDBT53V-P1M	1	PCB Antenna	512 kb	1 MB

Release Note

- 2020/09/01 Version A: 1ST release
- 2020/11/23 Version B
 - (1) Added info of working distance at the front page
 - (2) Updated photos of the module, weight info, contexts of the shield and tray info in Chapter 4: Shipment Packaging Information.
 - (3) Removed the description of NFC in Chapter 8: Reference Circuit.
 - (4) Added Chapter 9: Certification.
- 2022/07/01 Version C
 - (1) Updated Chapter 4: 4.2.1 Tray Packaging.
 - (2) Added Chapter 4: 4.2.2 Tape & Reel Packaging with 4.3 Order Code.
 - (3) Updated Chapter 2: 2.3 RF Layout Suggestion (aka Keep-Out Area).
 - (4) Updated MPQ information for Tray Packaging in Chapter 4: Shipment Packaging Information.
 - (5) Added Part No. information in front cover.
 - (6) Updated List of Raytac's Model no.
 - (7) Updated Chapter 5: Specification corresponding to Nordic's new nRF52820 Product Specification V1.3.