



FEATURES:

- Switching Regulator
- Low Noise
- Wide Input
- Non-Isolated
- Adjustable Output Voltage
- High MTBF
- SMD Package
- Efficiency Up To 95%
- Remote On/Off
- Short Circuit Protection
- Low Quiescent Current 0.2mA
- RoHS Compliant

Models

Single output

Model	Input Voltage (V)	Output Voltage (V)	Output Current max (mA)	Efficiency Vin Max (%)	Efficiency Vin (%) 
AMSRL-781.5JZ	4.75-28	1.5	500	67	76
AMSRL-781.8JZ	4.75-28	1.8	500	69	76
AMSRL-782.5JZ	4.75-32	2.5	500	74	81
AMSRL-783.3JZ	4.75-36	3.3	500	80	86
AMSRL-7805JZ	6.5-36	5	500	84	90
AMSRL-786.5JZ	8-36	6.5	500	87	92
AMSRL-7809JZ	12-36	9	500	90	93
AMSRL-7812JZ	15-36	12	500	91	94
AMSRL-7815JZ	19-36	15	500	93	95

NOTE: All specifications in this datasheet are measured at an ambient temperature of 25°C, humidity<75%, nominal input voltage and at rated output load unless otherwise specified.

Input Specifications

Parameters	Nominal	Typical	Maximum	Units
Voltage range	See Models table above			
On/Off Control	ON –open or 3.2V < Vc < 8V ; OFF –GND or 0V < VC < 0.8V , 30uA			
Quiescent Current	Vin = min to max at 0% load	0.2	1.5	mA

Output Specifications

Parameters	Conditions	Typical	Maximum	Units	
Voltage accuracy	At 100% load	1.5/1.8/2.5/3.3V	±2	±4	%
		Others	±2	±3	
Short Circuit protection	Continuous, hiccup mode				
Short circuit restart	Auto-Recovery				
Dynamic load stability	25% load step change	±25	±100	mV	
Transient recovery time	25% load step change	0.2	1	ms	
Line voltage regulation	Vin=(LL-HL) at full load	±0.2	±0.4	%	
Load voltage regulation	10-100% load	1.5/1.8/2.5/3.3V	±0.6		%
		Others	±0.3		
Temperature coefficient	-40°C to +85°C ambient	±0.03		%/°C	
Ripple & Noise	1.5/1.8/2.5/3.3VDC output, 20-100% load, 20MHz Bandwidth	20	50	mV p-p	
	Others output, 10-100% load, 20MHz Bandwidth	20	50		
Voltage adjustment range (Vadj)		±10		%Vout	
Maximum Capacitive Load			680	uF	

NOTE:

*1. Ripple and noise tested with “parallel cable” method;

*2. With the load lower than 20%, the maximum ripple and noise of 1.5/1.8/2.5/3.3V output products will be 100mVp-p; With the load lower than 10%,5V/6.5V/9V/12V/15V output products will be 150mVp-p.

General Specifications

Parameters	Conditions	Typical	Maximum	Units
------------	------------	---------	---------	-------

Switching frequency	100% load	3.3V output Others	370 700		KHz
Operating temperature	With derating above 71 °C		-40 to +85		°C
Storage temperature	-55 to +125				°C
Maximum case temperature				100	°C
Cooling	Free Air Convection				
Humidity				95	% RH
Case material	Plastic (UL94-V0)				
Weight	1.5				g
Dimensions (L x W x H)	0.60 x 0.45 x 0.32 Inches		15.24 x 11.40 x 8.25 mm		
MTBF	> 2 000 000 hrs (MIL-HDBK-217F, Ground Benign, t=+25 °C)				
Maximum Soldering Temperature	1.5mm from case for 10 sec			245	°C
Off idle current				30	100
					uA

Safety Specifications

Parameters		
Standards	Information Technology Equipment	Design to meet EN 62368
	EMI - Conducted and radiated emission	CISPR32 / EN55032, class B (with the recommended EMI circuit)
	Electrostatic Discharge Immunity	IEC 61000-4-2, Contact ±4KV, Criteria B
	RF, Electromagnetic Field Immunity	IEC 61000-4-3, 10V/m, Criteria A
	Electrical Fast Transient / Burst Immunity	IEC 61000-4-4, ±1KV, Criteria B, with the recommended EMS circuit
	Surge Immunity	IEC 61000-4-5, L-L ±1KV, Criteria B, with the recommended EMS circuit
	RF, Conducted Disturbance Immunity	IEC 61000-4-6, 3 Vrms, Criteria A

Pin Out Specifications

Pin	Single
1	+V input
2	+V input
3	Ground
4	+V output
5	+V output
6	V adj
7	Ground
10	ON/OFF

Dimensions & PCB Foot Print

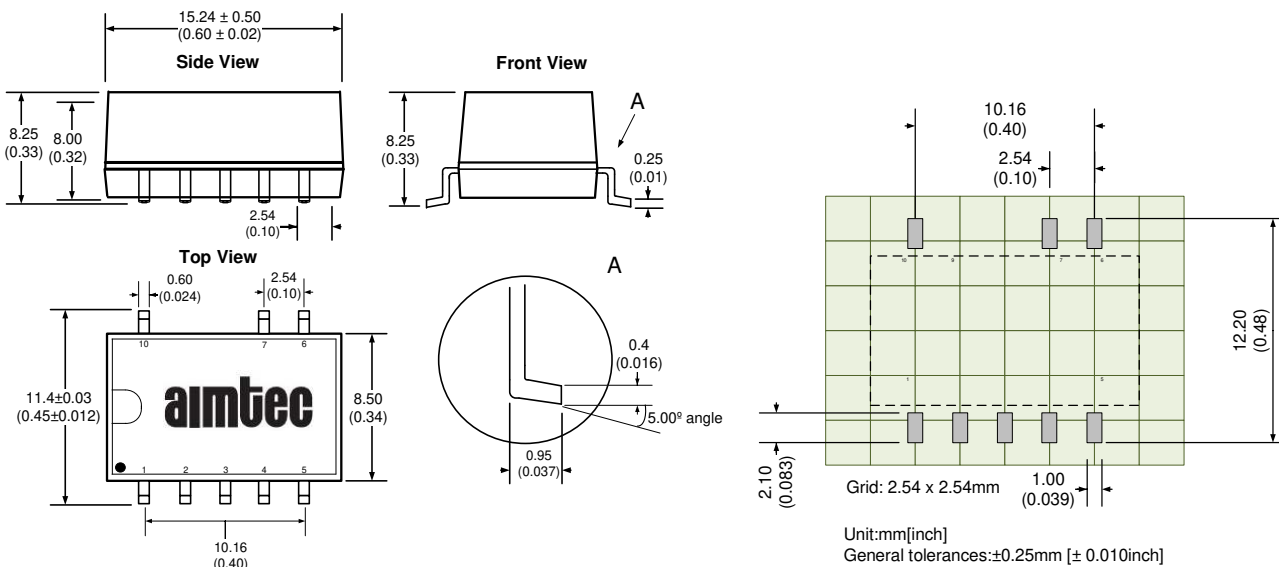

Derating

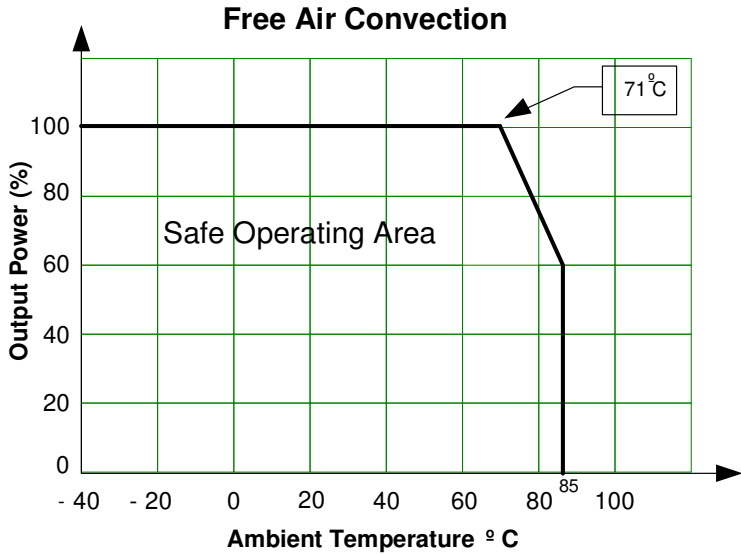

Application Circuit

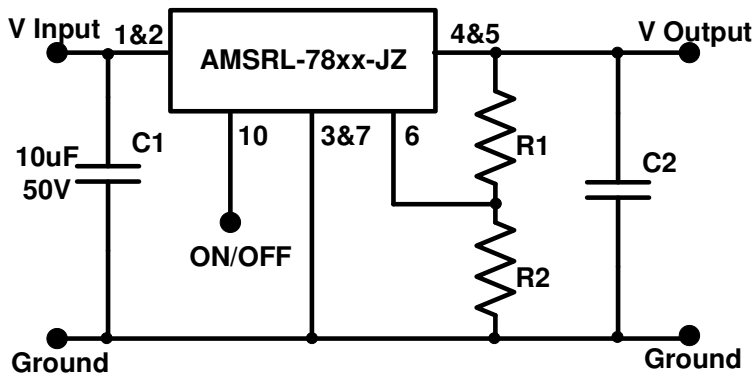

Model	C2 (uF)
1.5/1.8/2.5/3.3V output	22uF / 10V
5/6.5V output	22uF / 16V
9/12/15V output	22uF / 25V

LC filter Application Circuit

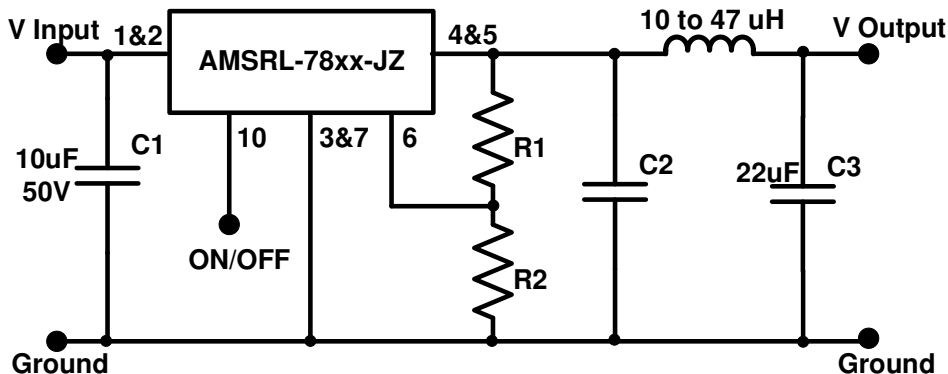

EMC Recommended Circuits

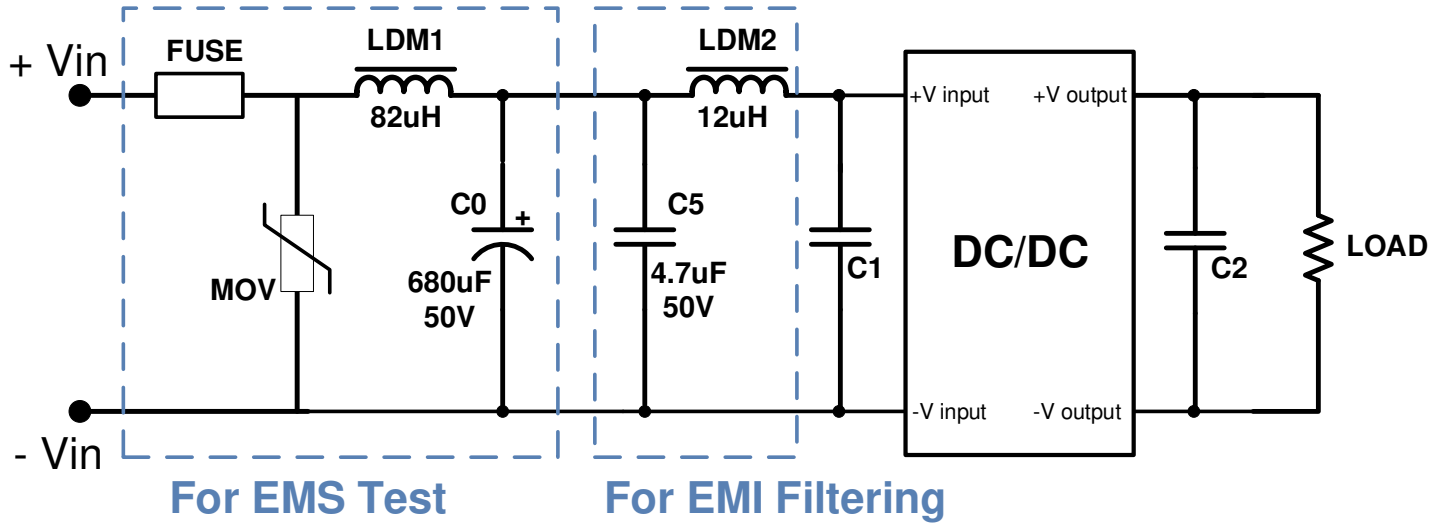

It is recommended that tantalum or low ESR electrolytic capacitors are used for C1 & C2. C1 & C2 are required and should be installed as close to the converter as possible

Trimming

Output voltage can be externally trimmed by utilizing the methods as shown below

Fixed Resistor Variable Potentiometer

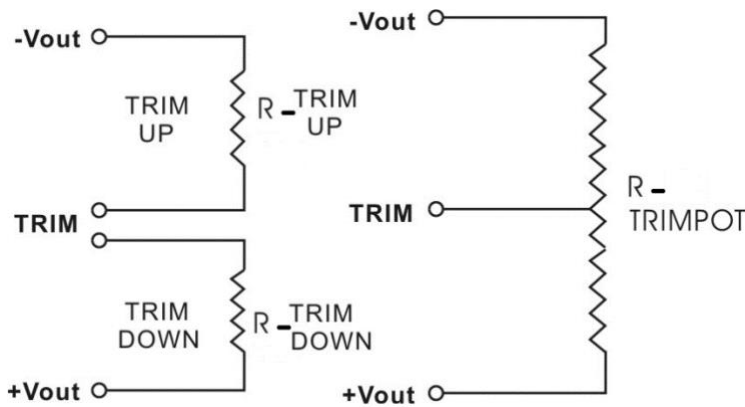

Leave open if not used.

Note: For the 1.5VDC output model is only support Vadj up, the Vadj down is unsupported.

AMSRL-781.5-JZ

Trim up %	1%	2%	3%	4%	5%	6%	7%	8%	9%	10%
Vout (VDC)	1.515	1.53	1.545	1.56	1.575	1.59	1.605	1.62	1.635	1.65
R2 (KΩ)	360.000	172.500	110.000	78.750	60.000	47.500	38.571	31.875	26.667	22.500

AMSRL-781.8-JZ

Trim down %	1%	2%	3%	4%	5%	6%	7%	8%	9%	10%
Vout (VDC)	1.782	1.764	1.746	1.728	1.71	1.692	1.674	1.656	1.638	1.62
R1 (KΩ)	1564.153	795.704	505.733	353.448	259.599	195.965	149.977	115.190	87.955	66.054
Trim up %	1%	2%	3%	4%	5%	6%	7%	8%	9%	10%
Vout (VDC)	1.818	1.836	1.854	1.872	1.89	1.908	1.926	1.944	1.962	1.98
R2 (KΩ)	1825.585	748.601	444.219	300.547	216.890	162.140	123.521	94.820	72.651	55.012

AMSRL-782.5-JZ

Trim down %	1%	2%	3%	4%	5%	6%	7%	8%	9%	10%
Vout (VDC)	2.475	2.45	2.425	2.4	2.375	2.35	2.325	2.3	2.275	2.25
R1 (KΩ)	1398.060	749.094	496.507	362.103	278.663	221.819	180.604	149.351	124.837	105.095
Trim up %	1%	2%	3%	4%	5%	6%	7%	8%	9%	10%
Vout (VDC)	2.525	2.55	2.575	2.6	2.625	2.65	2.675	2.7	2.725	2.75
R2 (KΩ)	1087.772	427.813	252.135	170.768	123.838	93.301	71.846	55.944	43.688	33.952

AMSRL-783.3-JZ

Trim down %	1%	2%	3%	4%	5%	6%	7%	8%	9%	10%
Vout (VDC)	3.267	3.234	3.201	3.168	3.135	3.102	3.069	3.036	3.003	2.97
R1 (KΩ)	1673.125	958.889	658.158	492.449	387.500	315.070	262.073	221.613	189.712	163.913
Trim up %	1%	2%	3%	4%	5%	6%	7%	8%	9%	10%
Vout (VDC)	3.333	3.366	3.399	3.432	3.465	3.498	3.531	3.564	3.597	3.63
R2 (KΩ)	1355.500	448.000	253.536	168.769	121.300	90.951	69.875	54.386	42.521	33.143

AMSRL-7805-JZ

Trim down %	1%	2%	3%	4%	5%	6%	7%	8%	9%	10%
Vout (VDC)	4.95	4.9	4.85	4.8	4.75	4.7	4.65	4.6	4.55	4.5
R1 (KΩ)	4753.846	2621.739	1781.818	1332.558	1052.830	861.905	723.288	618.072	535.484	468.932
Trim up %	1%	2%	3%	4%	5%	6%	7%	8%	9%	10%
Vout (VDC)	5.05	5.1	5.15	5.2	5.25	5.3	5.35	5.4	5.45	5.5
R2 (KΩ)	1564.286	600.000	350.000	235.135	169.149	126.316	96.269	74.026	56.897	43.299

AMSRL-786.5-JZ

Trim down %	1%	2%	3%	4%	5%	6%	7%	8%	9%	10%
Vout (VDC)	6.435	6.37	6.305	6.24	6.175	6.11	6.045	5.98	5.915	5.85
R1 (KΩ)	6249.000	3121.642	2052.797	1513.286	1187.931	970.338	814.574	697.565	606.447	533.483
Trim up %	1%	2%	3%	4%	5%	6%	7%	8%	9%	10%
Vout (VDC)	6.565	6.63	6.695	6.76	6.825	6.89	6.955	7.02	7.085	7.15
R2 (KΩ)	867.000	399.000	247.052	171.816	126.907	97.065	75.796	59.870	47.498	37.610

AMSRL-7809-JZ

Trim down %	1%	2%	3%	4%	5%	6%	7%	8%	9%	10%
Vout (VDC)	8.91	8.82	8.73	8.64	8.55	8.46	8.37	8.28	8.19	8.1
R1 (KΩ)	2634.699	1642.506	1181.744	915.640	742.353	620.531	530.212	460.575	405.246	360.226
Trim up %	1%	2%	3%	4%	5%	6%	7%	8%	9%	10%
Vout (VDC)	9.09	9.18	9.27	9.36	9.45	9.54	9.63	9.72	9.81	9.9
R2 (KΩ)	1602.960	315.429	164.310	105.733	74.618	55.321	42.183	32.662	25.444	19.784

AMSRL-7812-JZ

Trim down %	1%	2%	3%	4%	5%	6%	7%	8%	9%	10%
Vout (VDC)	11.88	11.76	11.64	11.52	11.4	11.28	11.16	11.04	10.92	10.8
R1 (KΩ)	6148.000	3206.824	2148.000	1602.545	1269.951	1045.959	884.842	763.385	668.548	592.444
Trim up %	1%	2%	3%	4%	5%	6%	7%	8%	9%	10%
Vout (VDC)	12.12	12.24	12.36	12.48	12.6	12.72	12.84	12.96	13.08	13.2
R2 (KΩ)	519.429	228.000	139.304	96.387	71.077	54.383	42.545	33.714	26.873	21.418

AMSRL-7815-JZ

Trim down %	1%	2%	3%	4%	5%	6%	7%	8%	9%	10%
Vout (VDC)	14.85	14.7	14.55	14.4	14.25	14.1	13.95	13.8	13.65	13.5
R1 (KΩ)	11796.843	4586.466	2815.401	2014.460	1557.921	1262.954	1056.683	904.330	787.198	694.340
Trim up %	1%	2%	3%	4%	5%	6%	7%	8%	9%	10%
Vout (VDC)	15.15	15.3	15.45	15.6	15.75	15.9	16.05	16.2	16.35	16.5
R2 (KΩ)	283.056	151.049	97.881	69.165	51.186	38.871	29.907	23.091	17.733	13.411

If it is needed to adjust the output voltage higher or lower than the converter's nominal value use the table above to determine appropriate resistor values, insuring that the voltage is within the adjustment range for the converter used.
If no voltage adjustment is needed connect a 470pF ceramic capacitor from pin 6 to ground.

NOTE: **1.** Datasheets are updated as needed and as such, specifications are subject to change without notice. Once printed or downloaded, datasheets are no longer controlled by Aimtec; refer to www.aimtec.com for the most current product specifications. **2.** Product labels shown, including safety agency certifications on labels, may vary based on the date manufactured. **3.** Mechanical drawings and specifications are for reference only. **4.** All specifications are measured at an ambient temperature of 25°C, humidity<75%, nominal input voltage and at rated output load unless otherwise specified. **5.** Aimtec may not have conducted destructive testing or chemical analysis on all internal components and chemicals at the time of publishing this document. CAS numbers and other limited information are considered proprietary and may not be available for release. **6.** This product is not designed for use in critical life support systems, equipment used in hazardous environments, nuclear control systems or other such applications which necessitate specific safety and regulatory standards other the ones listed in this datasheet. **7.** Warranty is in accordance with Aimtec's standard Terms of Sale available at www.aimtec.com.