

PART NO. SEE CHART  
 DWG. NO. SDA-90075

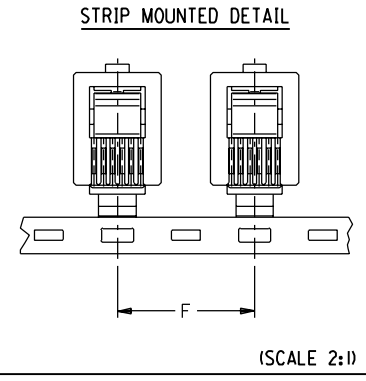
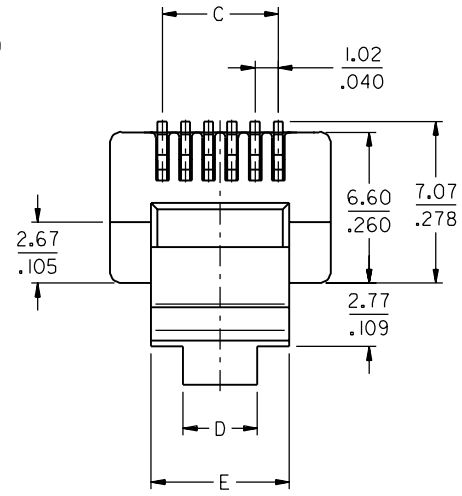
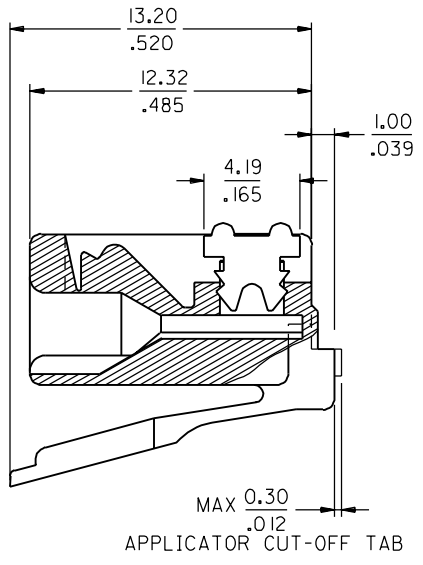
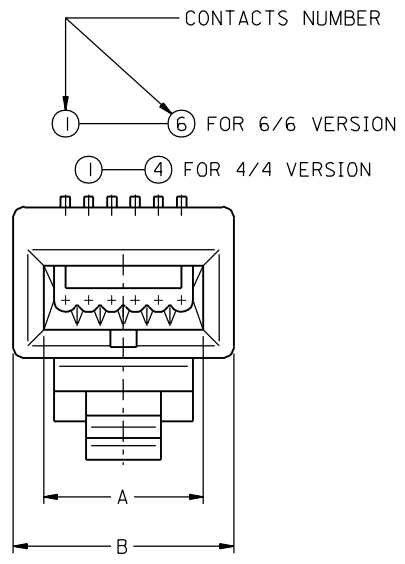

**NOTES:**

- 1- MATERIAL:  
 HOUSING: POLYCARBONATE CLEAR  
 TERMINAL: 0.38/.015 THICK PHOSPHOR BRONZE  
 PLATING: SEE PLATINGS CHART
- 2- PRODUCT INTENDED TO TERMINATE FLAT OVAL CABLE CONFORMING TO REA BULLETIN 345-80-PE 75 HAVING 0.94/.037 Ø MAXI OVER CONDUCTORS INSULATION
- 3- PRODUCT SPECIFICATION: PS-90075
- 4- APPLICATION SPECIFICATION: AS-90075

CKTS	NUMBER OF LOADED CONTACTS	PLATING	STRIP MOUNTED		LOOSE PIECE		DIMENSIONS					
			PART NUMBER	TOOLED	PART NUMBER	TOOLED	A	B	C	D	E	F
4	4	1	90075-0001	YES	90075-0003	YES	5.21	7.62	3.05	2.54	4.95	12.00
		2	90075-0025	YES	90075-0027	YES	.205	.300	.120	.100	.195	.472
6	2	1	N/A	-	N/A	-			1.02			
		3	90075-0171	YES	N/A	-			.040			
	4	1	90075-0009	YES	90075-0011	YES	6.99	9.65		3.25	6.05	15.00
		2	90075-0033	YES	90075-0035	YES	.275	.380	5.08	.128	.238	.591
6	6	1	90075-0005	YES	90075-0007	YES			.200			
		2	90075-0029	YES	90075-0031	YES						

PLATINGS	
①	0.00076/.000030 MIN GOLD IN CONTACT AREA 0.00127/.000050 MIN TIN LEAD IN PIERCE AREA BOTH OVER 0.00127/.000050 MIN NICKEL.
②	0.00127/.000050 MIN GOLD IN CONTACT AREA 0.00127/.000050 MIN TIN LEAD IN PIERCE AREA BOTH OVER 0.00127/.000050 MIN NICKEL.
③	0.00038/.000015 MIN GOLD IN CONTACT AREA 0.00100/.000039 MIN TIN LEAD IN PIERCE AREA BOTH OVER 0.00100/.000039 MIN NICKEL.

VERSION 6/2 ADDED ECN MC1999-0325 FB 99/06/09		REDRAWN ON CAD SYST. ECN 2369 FB 96/12/09		<b>REVISIONS</b> FOR PREVIOUS REVISIONS SEE MRI LIST UNLESS OTHERWISE SPECIFIED TOLERANCES: ANGULAR ±2° INCH METRIC 3 PLACE ± .010 ± 2 PLACE ± .014 ± 0.25 1 PLACE ± . ± 0.35 DRAFT WHERE APPLICABLE MUST REMAIN WITHIN DIMENSIONS DESIGN DIMENSION <input checked="" type="checkbox"/> MM <input type="checkbox"/> IN. EQUIVALENT DIMENSION <input type="checkbox"/> MM <input checked="" type="checkbox"/> IN. IF TWO DIMENSIONS ARE SHOWN THE UPPER IS THE DESIGN DIMENSION, LOWER IS SECONDARY		DRWG BY <b>FB</b> CHK'D BY <b>TB</b> APP'D BY <b>JB</b> SCALE <b>5:1</b>	SH. REV. CAD/CAM PROJECT NAME 590075X2. DGN THIS DRAWING CONTAINS INFORMATION THAT IS PROPRIETARY TO MOLEX INC. & SHOULD NOT BE USED WITHOUT WRITTEN PERMISSION TITLE <b>W.E. TYPE MODULAR PLUG          4/4, 6/4 AND 6/6          FOR OVAL FLAT CABLE</b> SHEET NO. DATE <b>2 OF 3   97/12/09</b> PART NO. DWG NO. <b>SEE CHART SDA-90075</b> SIZE <b>B</b>
---	--	---	--	--	--	---	--