

FEATURES

- 4.7 Ω maximum on resistance at 25°C**
- 0.5 Ω on-resistance flatness**
- Fully specified at ± 15 V/ $+12$ V/ ± 5 V**
- 3 V logic-compatible inputs**
- Up to 115 mA continuous current per channel**
- Rail-to-rail operation**
- Break-before-make switching action**
- 16-/20-lead TSSOP and 4 mm \times 4 mm LFCSP**

APPLICATIONS

- Relay replacement**
- Audio and video routing**
- Automatic test equipment**
- Data acquisition systems**
- Temperature measurement systems**
- Avionics**
- Battery-powered systems**
- Communication systems**
- Medical equipment**

GENERAL DESCRIPTION

The **ADG1433** and **ADG1434** are monolithic industrial CMOS (*i*CMOS[®]) analog switches comprising three independently selectable single-pole, double-throw (SPDT) switches and four independently selectable SPDT switches, respectively.

All channels exhibit break-before-make switching action that prevents momentary shorting when switching channels. An \overline{EN} input on the **ADG1433** (LFCSP and TSSOP) and **ADG1434** (LFCSP only) enables or disables the device. When disabled, all channels are switched off.

The *i*CMOS modular manufacturing process combines high voltage, complementary metal-oxide semiconductor (CMOS), and bipolar technologies. It enables the development of a wide range of high performance analog ICs capable of 33 V operation in a footprint that no other generation of high voltage devices has been able to achieve. Unlike analog ICs using a conventional CMOS process, *i*CMOS components can tolerate high supply voltages while providing increased performance, dramatically lower power consumption, and reduced package size.

The ultralow on resistance and on resistance flatness of these switches make them ideal solutions for data acquisition and gain switching applications, where low distortion is critical. *i*CMOS construction ensures ultralow power dissipation, making the devices ideally suited for portable and battery-powered instruments.

Rev. E

[Document Feedback](#)

Information furnished by Analog Devices is believed to be accurate and reliable. However, no responsibility is assumed by Analog Devices for its use, nor for any infringements of patents or other rights of third parties that may result from its use. Specifications subject to change without notice. No license is granted by implication or otherwise under any patent or patent rights of Analog Devices. Trademarks and registered trademarks are the property of their respective owners.

FUNCTIONAL BLOCK DIAGRAMS

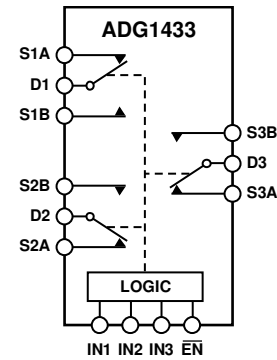
 SWITCHES SHOWN FOR
A 1 INPUT LOGIC.

06181-001

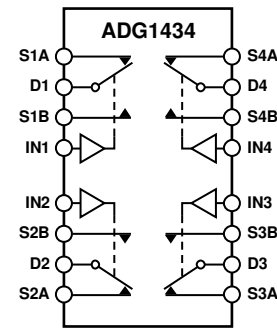
 Figure 1. **ADG1433** TSSOP and LFCSP

 SWITCHES SHOWN FOR
A 1 INPUT LOGIC.

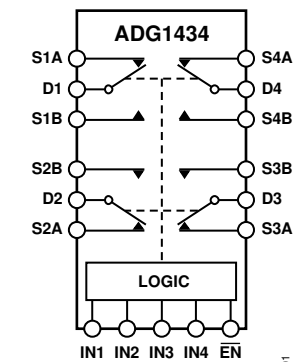
06181-002

 Figure 2. **ADG1434** TSSOP

 SWITCHES SHOWN FOR
A 1 INPUT LOGIC.

06181-101

 Figure 3. **ADG1434** LFCSP

TABLE OF CONTENTS

Features	1	Absolute Maximum Ratings	7
Applications.....	1	Thermal Resistance.....	7
General Description	1	ESD Caution.....	7
Functional Block Diagrams.....	1	Pin Configurations and Function Descriptions	8
Revision History	2	Typical Performance Characteristics	10
Specifications.....	3	Test Circuits.....	13
± 15 V Dual Supply	3	Terminology	15
12 V Single Supply.....	5	Outline Dimensions	16
± 5 V Dual Supply	6	Ordering Guide	17

REVISION HISTORY

8/2016—Rev. D to Rev. E

Changes to Analog Inputs Parameter and Digital Inputs Parameter, Table 4.....	7
--	---

3/2016—Rev. C to Rev. D

Changed CP-20-4 to CP-20-10 and CP-16-13 to CP-16-26	Throughout
Changes to Figure 5 and Table 6.....	8
Changes to Figure 6, Figure 7, and Table 8	9
Changes to Figure 27.....	13
Changes to Figure 31, Figure 32, and Figure 33	14
Updated Outline Dimensions	16
Changes to Ordering Guide	17

6/2009—Rev. B to Rev. C

Updated Outline Dimensions	16
Changes to Ordering Guide	17

3/2009—Rev. A to Rev. B

Change to I_{DD} Parameter, Table 1	4
Change to I_{DD} Parameter, Table 2	5
Updated Outline Dimensions, Figure 39	17

6/2008—Rev. 0 to Rev. A

Added Continuous Current per Channel Parameter, Table 1	4
Added Continuous Current per Channel Parameter, Table 2	5
Added Continuous Current per Channel Parameter, Table 3	6
Changes to Table 4.....	7
Changes to Figure 30.....	13
Updated Outline Dimensions.....	16
Changes to Ordering Guide	17

10/2006—Revision 0: Initial Version

SPECIFICATIONS

±15 V DUAL SUPPLY

$V_{DD} = +15\text{ V} \pm 10\%$, $V_{SS} = -15\text{ V} \pm 10\%$, $GND = 0\text{ V}$, unless otherwise noted.

Table 1.

Parameter	+25°C	-40°C to +85°C	-40°C to +125°C ¹	Unit	Test Conditions/Comments
ANALOG SWITCH					
Analog Signal Range			V_{SS} to V_{DD}	V	
On Resistance, R_{ON}	4			Ω typ	$V_S = \pm 10\text{ V}$, $I_S = -10\text{ mA}$; see Figure 25
	4.7	5.7	6.7	Ω max	$V_{DD} = +13.5\text{ V}$, $V_{SS} = -13.5\text{ V}$
On Resistance Match Between Channels, ΔR_{ON}	0.5			Ω typ	$V_S = \pm 10\text{ V}$, $I_S = -10\text{ mA}$
	0.78	0.85	1.1	Ω max	
On Resistance Flatness, $R_{FLAT(ON)}$	0.5			Ω typ	$V_S = \pm 10\text{ V}$, $I_S = -10\text{ mA}$
	0.72	0.77	0.92	Ω max	
LEAKAGE CURRENTS					
Source Off Leakage, I_S (Off)	± 0.04			nA typ	$V_{DD} = +16.5\text{ V}$, $V_{SS} = -16.5\text{ V}$
	± 0.3	± 0.6	± 3	nA max	$V_D = \pm 10\text{ V}$, $V_S = \pm 10\text{ V}$; see Figure 26
Drain Off Leakage, I_D (Off)	± 0.04			nA typ	$V_D = \pm 10\text{ V}$, $V_S = \pm 10\text{ V}$; see Figure 26
	± 0.3	± 0.6	± 3	nA max	
Channel On Leakage, I_D , I_S (On)	± 0.05			nA typ	$V_S = V_D = \pm 10\text{ V}$; see Figure 27
	± 0.4	± 0.8	± 8	nA max	
DIGITAL INPUTS					
Input High Voltage, V_{IH}			2.0	V min	
Input Low Voltage, V_{IL}			0.8	V max	
Input Current, I_{IL} or I_{IH}	± 0.005			μA typ	$V_{IN} = V_{GND}$ or V_{DD}
			± 0.1	μA max	
Digital Input Capacitance, C_{IN}	3			pF typ	
DYNAMIC CHARACTERISTICS²					
Transition Time, t_{TRANS}	140			ns typ	$R_L = 100\ \Omega$, $C_L = 35\text{ pF}$
	170	200	230	ns max	$V_S = 10\text{ V}$, see Figure 28
Break-Before-Make Time Delay, t_D	40			ns typ	$R_L = 100\ \Omega$, $C_L = 35\text{ pF}$
			30	ns min	$V_{S1} = V_{S2} = 10\text{ V}$, see Figure 29
$t_{ON}(\overline{EN})$	140			ns typ	$R_L = 100\ \Omega$, $C_L = 35\text{ pF}$
	170	200	230	ns max	$V_S = 10\text{ V}$, see Figure 30
$t_{OFF}(\overline{EN})$	60			ns typ	$R_L = 100\ \Omega$, $C_L = 35\text{ pF}$
	75	85	90	ns max	$V_S = 10\text{ V}$, see Figure 30
Charge Injection	-50			pC typ	$V_S = 0\text{ V}$, $R_S = 0\ \Omega$, $C_L = 1\text{ nF}$, see Figure 31
Off Isolation	-70			dB typ	$R_L = 50\ \Omega$, $C_L = 5\text{ pF}$, $f = 1\text{ MHz}$, see Figure 32
Channel-to-Channel Crosstalk	-70			dB typ	$R_L = 50\ \Omega$, $C_L = 5\text{ pF}$, $f = 1\text{ MHz}$, see Figure 34
Total Harmonic Distortion, THD + N	0.025			% typ	$R_L = 110\ \Omega$, 15 V p-p , $f = 20\text{ Hz to } 20\text{ kHz}$, see Figure 35
-3 dB Bandwidth	200			MHz typ	$R_L = 50\ \Omega$, $C_L = 5\text{ pF}$, see Figure 33
Insertion Loss	0.24			dB typ	$R_L = 50\ \Omega$, $C_L = 5\text{ pF}$, $f = 1\text{ MHz}$, see Figure 33
C_S (Off)	12			pF typ	$f = 1\text{ MHz}$
C_D (Off)	22			pF typ	$f = 1\text{ MHz}$
C_D , C_S (On)	72			pF typ	$f = 1\text{ MHz}$

Parameter	+25°C	-40°C to +85°C	-40°C to +125°C ¹	Unit	Test Conditions/Comments
POWER REQUIREMENTS					
I_{DD}	0.001		1	$\mu\text{A typ}$ $\mu\text{A max}$	$V_{DD} = +16.5\text{ V}$, $V_{SS} = -16.5\text{ V}$ Digital inputs = 0 V or V_{DD}
I_{DD}	260		475	$\mu\text{A typ}$ $\mu\text{A max}$	Digital inputs = 5 V
I_{SS}	0.001		1	$\mu\text{A typ}$ $\mu\text{A max}$	Digital inputs = 0 V, 5 V, or V_{DD}
V_{DD}/V_{SS}			$\pm 4.5/\pm 16.5$	V min/max	GND = 0 V
Continuous Current per Channel ²					$V_{DD} = +13.5\text{ V}$, $V_{SS} = -13.5\text{ V}$
ADG1433	115	75	40	mA max	
ADG1434	100	65	40	mA max	

¹ Temperature range for Y version: -40°C to +125°C.

² Guaranteed by design, not subject to production test.

12 V SINGLE SUPPLY

$V_{DD} = 12\text{ V} \pm 10\%$, $V_{SS} = 0\text{ V}$, $GND = 0\text{ V}$, unless otherwise noted.

Table 2.

Parameter	+25°C	-40°C to +85°C	-40°C to +125°C ¹	Unit	Test Conditions/Comments
ANALOG SWITCH					
Analog Signal Range			0 to V_{DD}	V	
On Resistance, R_{ON}	6			Ω typ	$V_S = 0\text{ V}$ to 10 V , $I_S = -10\text{ mA}$, see Figure 25
	8	9.5	11.2	Ω max	$V_{DD} = 10.8\text{ V}$, $V_{SS} = 0\text{ V}$
On Resistance Match Between Channels, ΔR_{ON}	0.55			Ω typ	$V_S = 0\text{ V}$ to 10 V , $I_S = -10\text{ mA}$
	0.82	0.85	1.1	Ω max	
On Resistance Flatness, $R_{FLAT(ON)}$	1.5			Ω typ	$V_S = 0\text{ V}$ to 10 V , $I_S = -10\text{ mA}$
	2.5	2.5	2.8	Ω max	
LEAKAGE CURRENTS					
Source Off Leakage, I_S (Off)	± 0.04			nA typ	$V_{DD} = 13.2\text{ V}$
	± 0.3	± 0.6	± 3	nA max	$V_S = 1\text{ V}/10\text{ V}$, $V_D = 10\text{ V}/1\text{ V}$, see Figure 26
Drain Off Leakage, I_D (Off)	± 0.04			nA typ	$V_S = 1\text{ V}/10\text{ V}$, $V_D = 10\text{ V}/1\text{ V}$, see Figure 26
	± 0.3	± 0.6	± 3	nA max	
Channel On Leakage, I_D , I_S (On)	± 0.06			nA typ	$V_S = V_D = 1\text{ V}$ or 10 V , see Figure 27
	± 0.4	± 0.8	± 8	nA max	
DIGITAL INPUTS					
Input High Voltage, V_{IH}			2.0	V min	
Input Low Voltage, V_{IL}			0.8	V max	
Input Current, I_{IL} or I_{IH}	± 0.005			μA typ	$V_{IN} = V_{GND}$ or V_{DD}
			± 0.1	μA max	
Digital Input Capacitance, C_{IN}	4			pF typ	
DYNAMIC CHARACTERISTICS²					
Transition Time, t_{TRANS}	200			ns typ	$R_L = 100\ \Omega$, $C_L = 35\text{ pF}$
	255	310	350	ns max	$V_S = 8\text{ V}$, see Figure 28
Break-Before-Make Time Delay, t_D	80			ns typ	$R_L = 100\ \Omega$, $C_L = 35\text{ pF}$
			55	ns min	$V_{S1} = V_{S2} = 8\text{ V}$, see Figure 29
$t_{ON}(\overline{EN})$	210			ns typ	$R_L = 100\ \Omega$, $C_L = 35\text{ pF}$
	270	320	360	ns max	$V_S = 8\text{ V}$, see Figure 30
$t_{OFF}(\overline{EN})$	70			ns typ	$R_L = 100\ \Omega$, $C_L = 35\text{ pF}$
	86	95	105	ns max	$V_S = 8\text{ V}$, see Figure 30
Charge Injection	-10			pC typ	$V_S = 6\text{ V}$, $R_S = 0\ \Omega$, $C_L = 1\text{ nF}$, see Figure 31
Off Isolation	-70			dB typ	$R_L = 50\ \Omega$, $C_L = 5\text{ pF}$, $f = 1\text{ MHz}$, see Figure 32
Channel-to-Channel Crosstalk	-70			dB typ	$R_L = 50\ \Omega$, $C_L = 5\text{ pF}$, $f = 1\text{ MHz}$, see Figure 34
-3 dB Bandwidth	135			MHz typ	$R_L = 50\ \Omega$, $C_L = 5\text{ pF}$, see Figure 33
Insertion Loss	0.5			dB typ	$R_L = 50\ \Omega$, $C_L = 5\text{ pF}$, $f = 1\text{ MHz}$, see Figure 33
C_S (Off)	25			pF typ	$f = 1\text{ MHz}$
C_D (Off)	45			pF typ	$f = 1\text{ MHz}$
C_D , C_S (On)	80			pF typ	$f = 1\text{ MHz}$
POWER REQUIREMENTS					
I_{DD}	0.002			μA typ	$V_{DD} = 13.2\text{ V}$
			1	μA max	Digital inputs = 0 V or V_{DD}
I_{DD}	260			μA typ	Digital inputs = 5 V
			475	μA max	
V_{DD}			5/16.5	V min/max	$V_{SS} = 0\text{ V}$, $GND = 0\text{ V}$
Continuous Current per Channel ²					$V_{DD} = +10.8\text{ V}$, $V_{SS} = 0\text{ V}$
ADG1433	100	65	40	mA max	
ADG1434	85	60	35	mA max	

¹ Temperature range for Y version: -40°C to +125°C.

² Guaranteed by design, not subject to production test.

±5 V DUAL SUPPLY

$V_{DD} = +5\text{ V} \pm 10\%$, $V_{SS} = -5\text{ V} \pm 10\%$, $GND = 0\text{ V}$, unless otherwise noted.

Table 3.

Parameter	+25°C	-40°C to +85°C	-40°C to +125°C ¹	Unit	Test Conditions/Comments
ANALOG SWITCH					
Analog Signal Range			V_{SS} to V_{DD}	V	
On Resistance (R_{ON})	7			Ω typ	$V_S = \pm 4.5\text{ V}$, $I_S = -10\text{ mA}$, see Figure 25
	9	10.5	12	Ω max	$V_{DD} = +4.5\text{ V}$, $V_{SS} = -4.5\text{ V}$
On Resistance Match Between Channels (ΔR_{ON})	0.55			Ω typ	$V_S = \pm 4.5\text{ V}$, $I_S = -10\text{ mA}$
	0.78	0.91	1.1	Ω max	
On Resistance Flatness, $R_{FLAT(ON)}$	1.5			Ω typ	$V_S = \pm 4.5\text{ V}$, $I_S = -10\text{ mA}$
	2.5	2.5	3	Ω max	
LEAKAGE CURRENTS					
Source Off Leakage, I_S (Off)	± 0.02			nA typ	$V_{DD} = +5.5\text{ V}$, $V_{SS} = -5.5\text{ V}$
	± 0.3	± 0.6	± 3	nA max	$V_D = \pm 4.5\text{ V}$, $V_S = \pm 4.5\text{ V}$, see Figure 26
Drain Off Leakage, I_D (Off)	± 0.02			nA typ	$V_D = \pm 4.5\text{ V}$, $V_S = \pm 4.5\text{ V}$, see Figure 26
	± 0.3	± 0.6	± 3	nA max	
Channel On Leakage, I_D , I_S (On)	± 0.04			nA typ	$V_S = V_D = \pm 4.5\text{ V}$, see Figure 27
	± 0.4	± 0.8	± 8	nA max	
DIGITAL INPUTS					
Input High Voltage, V_{IH}			2.0	V min	
Input Low Voltage, V_{IL}			0.8	V max	
Input Current, I_{IL} or I_{IH}	± 0.005			μA typ	$V_{IN} = V_{GND}$ or V_{DD}
			± 0.1	μA max	
Digital Input Capacitance, C_{IN}	4			pF typ	
DYNAMIC CHARACTERISTICS²					
Transition Time, t_{TRANS}	315			ns typ	$R_L = 100\ \Omega$, $C_L = 35\text{ pF}$
	430	480	550	ns max	$V_S = 5\text{ V}$, see Figure 28
Break-Before-Make Time Delay, t_D	90			ns typ	$R_L = 100\ \Omega$, $C_L = 35\text{ pF}$
			55	ns min	$V_{S1} = V_{S2} = 5\text{ V}$, see Figure 29
$t_{ON}(\overline{EN})$	325			ns typ	$R_L = 100\ \Omega$, $C_L = 35\text{ pF}$
	425	490	545	ns max	$V_S = 5\text{ V}$, see Figure 30
$t_{OFF}(\overline{EN})$	150			ns typ	$R_L = 100\ \Omega$, $C_L = 35\text{ pF}$
	200	225	240	ns max	$V_S = 5\text{ V}$, see Figure 30
Charge Injection	-10			pC typ	$V_S = 0\text{ V}$, $R_S = 0\ \Omega$, $C_L = 1\text{ nF}$, see Figure 31
Off Isolation	-70			dB typ	$R_L = 50\ \Omega$, $C_L = 5\text{ pF}$, $f = 1\text{ MHz}$, see Figure 32
Channel-to-Channel Crosstalk	-70			dB typ	$R_L = 50\ \Omega$, $C_L = 5\text{ pF}$, $f = 1\text{ MHz}$, see Figure 34
Total Harmonic Distortion, THD + N	0.06			% typ	$R_L = 110\ \Omega$, 5 V p-p, $f = 20\text{ Hz}$ to 20 kHz , see Figure 35
-3 dB Bandwidth	145			MHz typ	$R_L = 50\ \Omega$, $C_L = 5\text{ pF}$, see Figure 33
Insertion Loss	0.5			dB typ	$R_L = 50\ \Omega$, $C_L = 5\text{ pF}$, $f = 1\text{ MHz}$, see Figure 33
C_S (Off)	18			pF typ	$f = 1\text{ MHz}$
C_D (Off)	32			pF typ	$f = 1\text{ MHz}$
C_D , C_S (On)	80			pF typ	$f = 1\text{ MHz}$
POWER REQUIREMENTS					
I_{DD}	0.002			μA typ	$V_{DD} = +5.5\text{ V}$, $V_{SS} = -5.5\text{ V}$
			1	μA max	Digital inputs = 0 V, 5 V, or V_{DD}
I_{SS}	0.001			μA typ	Digital inputs = 0 V, 5 V, or V_{DD}
			1	μA max	
V_{DD}/V_{SS}			$\pm 4.5/\pm 16.5$	V min/max	$GND = 0\text{ V}$
Continuous Current per Channel ²					$V_{DD} = +4.5\text{ V}$, $V_{SS} = -4.5\text{ V}$
ADG1433	95	60	35	mA max	
ADG1434	85	55	35	mA max	

¹ Temperature range for Y version: -40°C to +125°C.

² Guaranteed by design, not subject to production test.

ABSOLUTE MAXIMUM RATINGS

$T_A = 25^\circ\text{C}$, unless otherwise noted.

Table 4.

Parameter	Rating
V_{DD} to V_{SS}	35 V
V_{DD} to GND	-0.3 V to +25 V
V_{SS} to GND	-25 V to +0.3 V
Analog Inputs ¹	$V_{SS} - 0.3\text{ V}$ to $V_{DD} + 0.3\text{ V}$ or 30 mA (whichever occurs first)
Digital Inputs ¹	GND - 0.3 V to $V_{DD} + 0.3\text{ V}$ or 30 mA (whichever occurs first)
Peak Current, S or D (Pulsed at 1 ms, 10% Duty Cycle Maximum)	250 mA
Continuous Current, S or D ²	Data + 15%
Operating Temperature Range	
Industrial (Y Version)	-40°C to +125°C
Storage Temperature Range	-65°C to +150°C
Junction Temperature	150°C
Reflow Soldering Peak Temperature (Pb-Free)	260 (+ 0 to -5)°C

¹ Overvoltages at A, $\overline{\text{EN}}$, S, or D pins are clamped by internal diodes. Current must be limited to the maximum ratings given.

² See data given in the Specifications section (see Table 1 to Table 3).

Stresses at or above those listed under Absolute Maximum Ratings may cause permanent damage to the product. This is a stress rating only; functional operation of the product at these or any other conditions above those indicated in the operational section of this specification is not implied. Operation beyond the maximum operating conditions for extended periods may affect product reliability.

Only one absolute maximum rating may be applied at any one time.

THERMAL RESISTANCE

θ_{JA} is specified for the worst-case conditions, that is, a device soldered in a circuit board for surface-mount packages.

Table 5.

Package Type	θ_{JA}	θ_{JC}	Unit
TSSOP	150.4	50	°C/W
LFCSF	30.4	N/A ¹	°C/W

¹ N/A means not applicable.

ESD CAUTION



ESD (electrostatic discharge) sensitive device. Charged devices and circuit boards can discharge without detection. Although this product features patented or proprietary protection circuitry, damage may occur on devices subjected to high energy ESD. Therefore, proper ESD precautions should be taken to avoid performance degradation or loss of functionality.

PIN CONFIGURATIONS AND FUNCTION DESCRIPTIONS

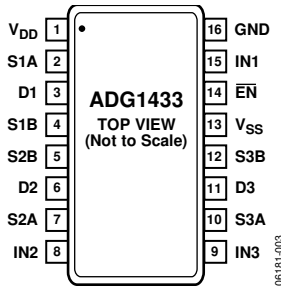

Figure 4. ADG1433 TSSOP Pin Configuration

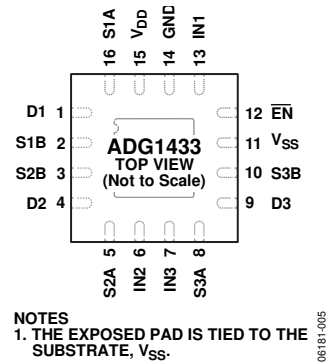

Figure 5. ADG1433 LFCSP Pin Configuration

Table 6. ADG1433 Pin Function Descriptions

Pin No.		Mnemonic	Description
TSSOP	LFCSP		
1	15	V _{DD}	Most Positive Power Supply Potential.
2	16	S1A	Source Terminal 1A. Can be an input or an output.
3	1	D1	Drain Terminal 1. Can be an input or an output.
4	2	S1B	Source Terminal 1B. Can be an input or an output.
5	3	S2B	Source Terminal 2B. Can be an input or an output.
6	4	D2	Drain Terminal 2. Can be an input or an output.
7	5	S2A	Source Terminal 2A. Can be an input or an output.
8	6	IN2	Logic Control Input 2.
9	7	IN3	Logic Control Input 3.
10	8	S3A	Source Terminal 3A. Can be an input or an output.
11	9	D3	Drain Terminal 3. Can be an input or an output.
12	10	S3B	Source Terminal 3B. Can be an input or an output.
13	11	V _{SS}	Most Negative Power Supply Potential. In single-supply applications, it can be connected to ground.
14	12	EN	Active Low Digital Input. When high, the device is disabled and all switches are off. When low, IN _x logic inputs determine the on switches.
15	13	IN1	Logic Control Input 1.
16	14	GND	Ground (0 V) Reference.
N/A ¹	0	EPAD	Exposed Pad. The exposed pad is tied to the substrate, V _{SS} .

¹ N/A means not applicable.

Table 7. ADG1433 Truth Table

EN	IN _x	S _x A	S _x B
1	X	Off	Off
0	0	Off	On
0	1	On	Off

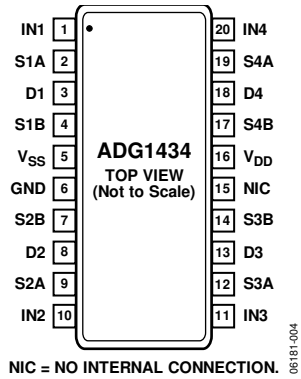

Figure 6. ADG1434 TSSOP Pin Configuration

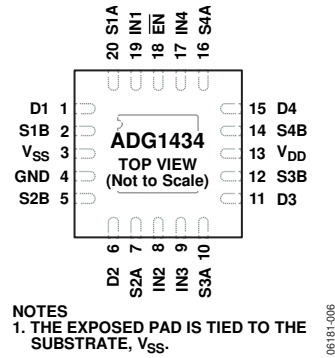

Figure 7. ADG1434 LFCSP Pin Configuration

Table 8. ADG1434 Pin Function Descriptions

Pin No.		Mnemonic	Description
TSSOP	LFCSP		
1	19	IN1	Logic Control Input 1.
2	20	S1A	Source Terminal 1A. Can be an input or an output.
3	1	D1	Drain Terminal 1. Can be an input or an output.
4	2	S1B	Source Terminal 1B. Can be an input or an output.
5	3	V _{SS}	Most Negative Power Supply Potential. In single-supply applications, it can be connected to ground.
6	4	GND	Ground (0 V) Reference.
7	5	S2B	Source Terminal 2B. Can be an input or an output.
8	6	D2	Drain Terminal 2. Can be an input or an output.
9	7	S2A	Source Terminal 2A. Can be an input or an output.
10	8	IN2	Logic Control Input 2.
11	9	IN3	Logic Control Input 3.
12	10	S3A	Source Terminal 3A. Can be an input or an output.
13	11	D3	Drain Terminal 3. Can be an input or an output.
14	12	S3B	Source Terminal 3B. Can be an input or an output.
15	N/A ¹	NIC	No Internal Connection.
16	13	V _{DD}	Most Positive Power Supply Potential.
17	14	S4B	Source Terminal 4B. Can be an input or an output.
18	15	D4	Drain Terminal 4. Can be an input or an output.
19	16	S4A	Source Terminal 4A. Can be an input or an output.
20	17	IN4	Logic Control Input 4.
N/A ¹	18	EN	Active Low Digital Input. When high, the device is disabled and all switches are off. When low, INx logic inputs determine the on switches.
N/A ¹	0	EPAD	Exposed Pad. The exposed pad is tied to the substrate, V _{SS} .

¹ N/A means not applicable.

Table 9. ADG1434 TSSOP Truth Table

INx	SxA	SxB
0	Off	On
1	On	Off

Table 10. ADG1434 LFCSP Truth Table

EN	INx	SxA	SxB
1	X	Off	Off
0	0	Off	On
0	1	On	Off

TYPICAL PERFORMANCE CHARACTERISTICS

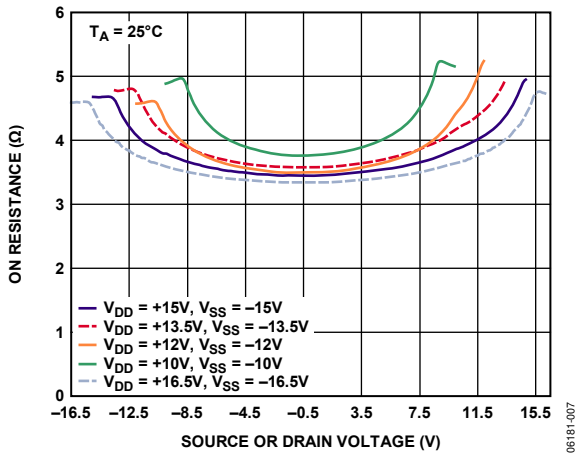

Figure 8. On Resistance as a Function of $V_D (V_S)$, Dual Supply

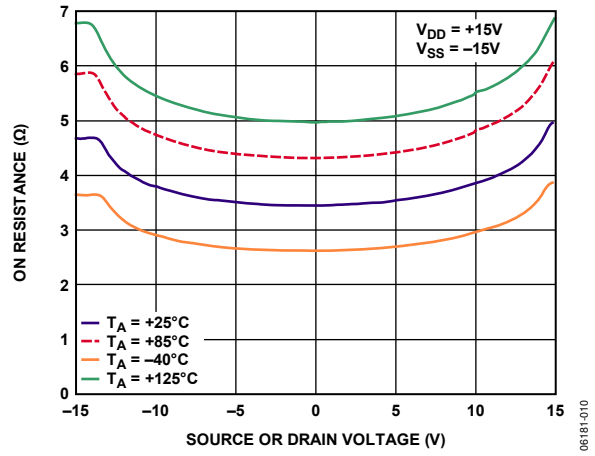

Figure 11. On Resistance as a Function of $V_D (V_S)$ for Different Temperatures, $\pm 15\text{V}$ Dual Supply

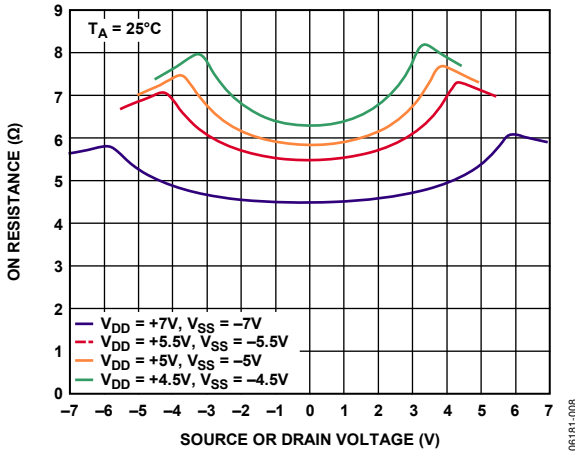

Figure 9. On Resistance as a Function of $V_D (V_S)$, Dual Supply

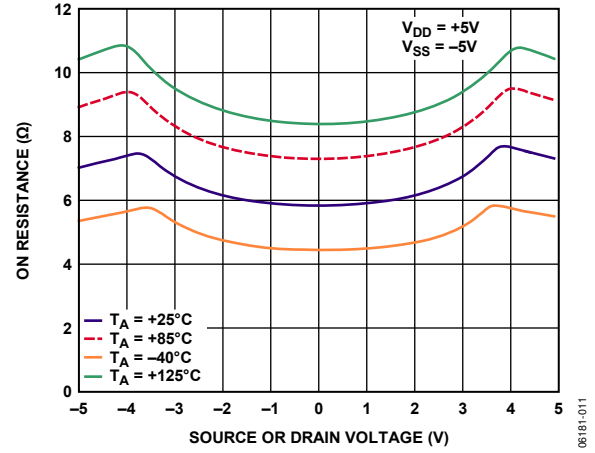

Figure 12. On Resistance as a Function of $V_D (V_S)$ for Different Temperatures, $\pm 5\text{V}$ Dual Supply

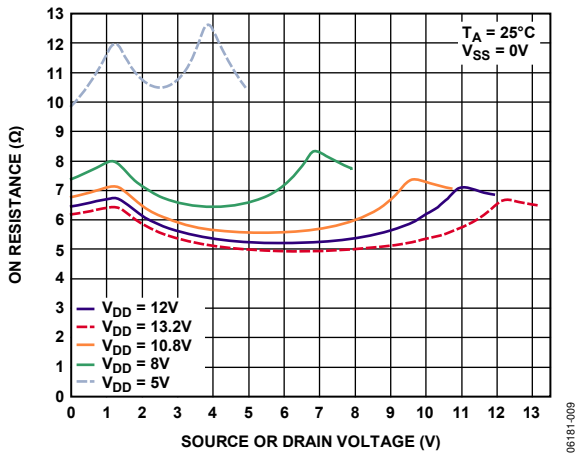

Figure 10. On Resistance as a Function of $V_D (V_S)$, Single Supply

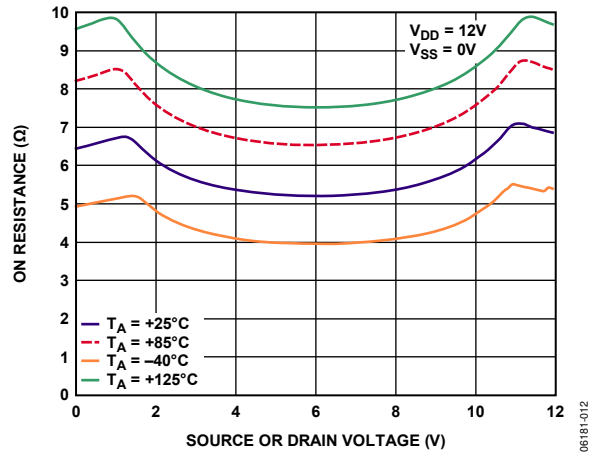

Figure 13. On Resistance as a Function of $V_D (V_S)$ for Different Temperatures, 12V Single Supply

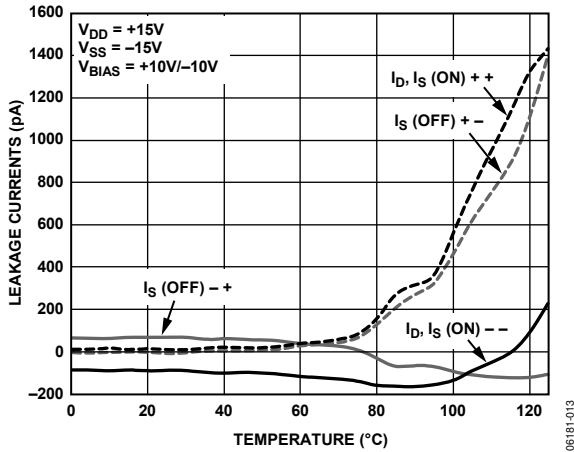

Figure 14. Leakage Currents as a Function of Temperature, ±15 V Dual Supply

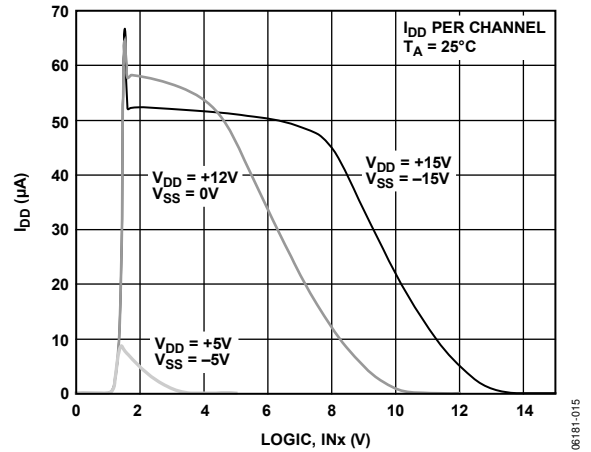

Figure 17. I_{DD} vs. Logic Level

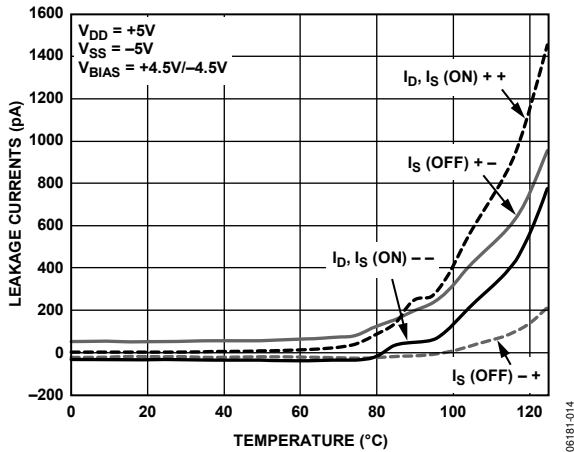

Figure 15. Leakage Currents as a Function of Temperature, ±5 V Dual Supply

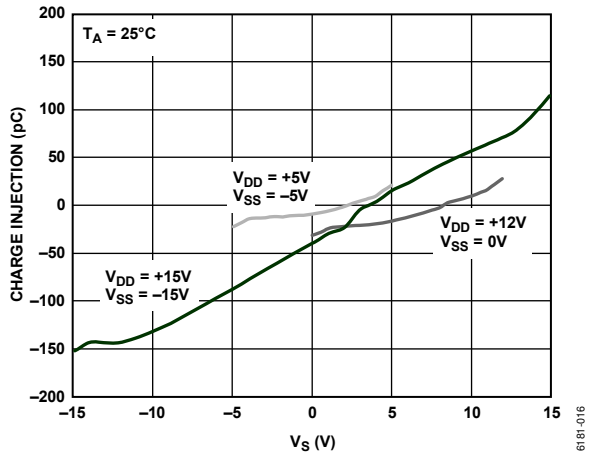

Figure 18. Charge Injection vs. Source Voltage

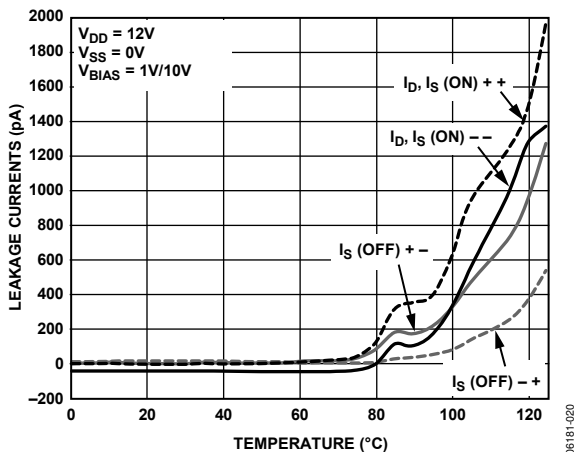

Figure 16. Leakage Currents as a Function of Temperature, 12 V Single Supply

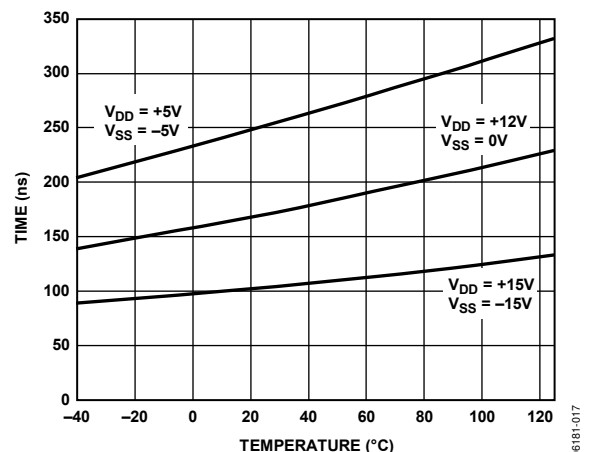

Figure 19. Transition Time vs. Temperature

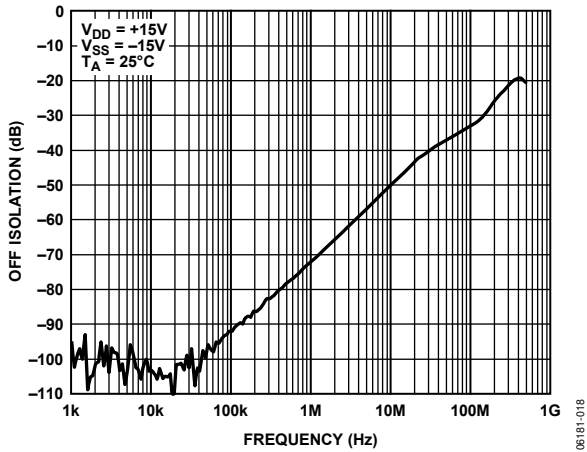

Figure 20. Off Isolation vs. Frequency

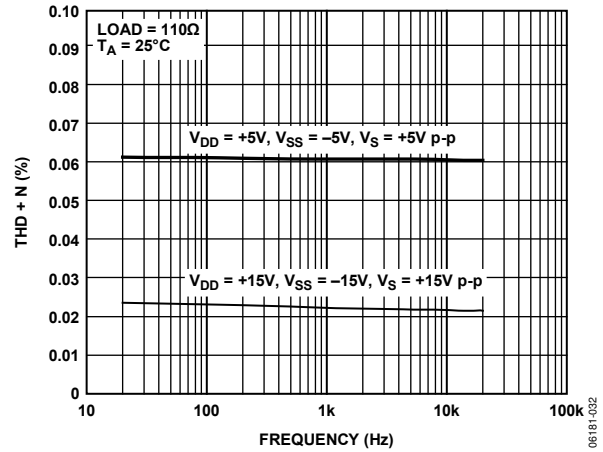

Figure 23. THD + N vs. Frequency

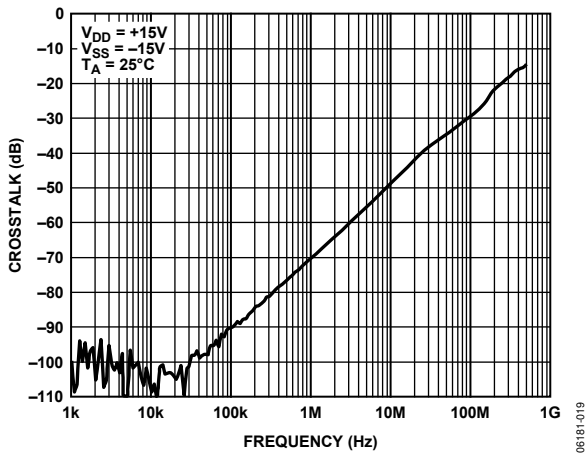

Figure 21. Crosstalk vs. Frequency

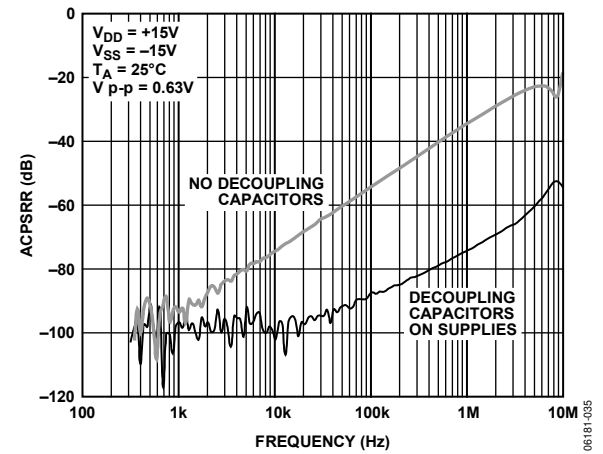

Figure 24. ACPSRR vs. Frequency

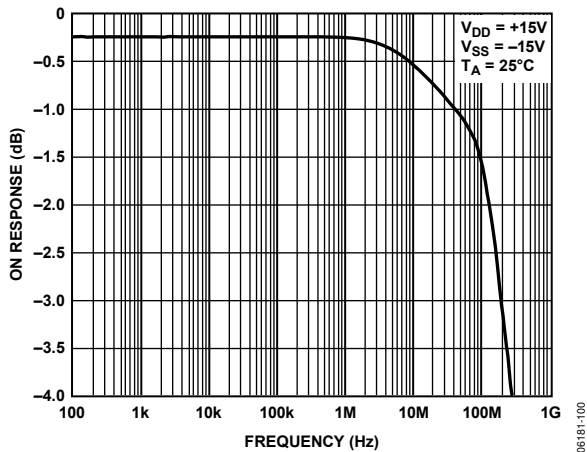

Figure 22. On Response vs. Frequency

TEST CIRCUITS

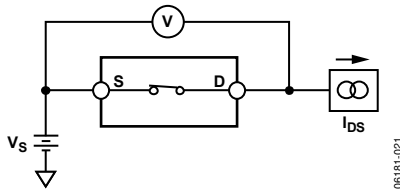

Figure 25. On Resistance

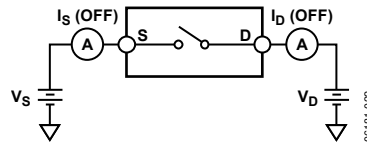
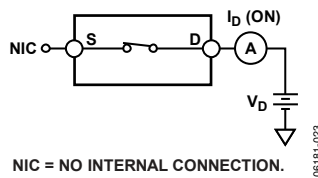

Figure 26. Off Leakage



NIC = NO INTERNAL CONNECTION.

Figure 27. On Leakage

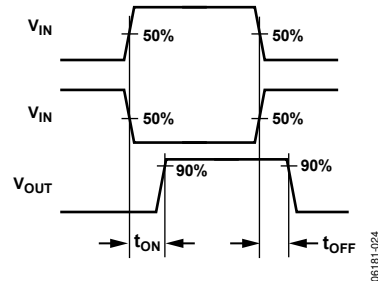
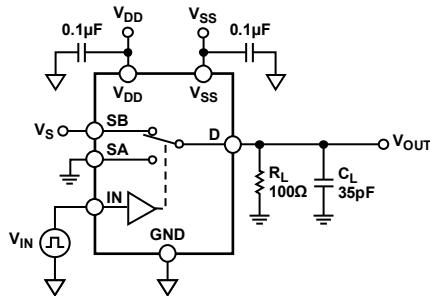

Figure 28. Switching Timing

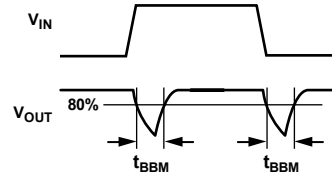
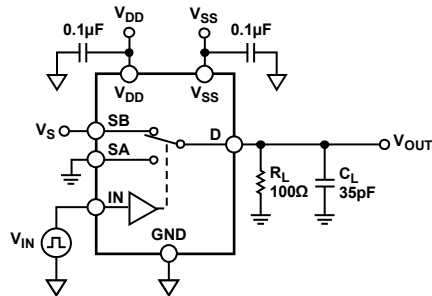

Figure 29. Break-Before-Make Delay, t_D

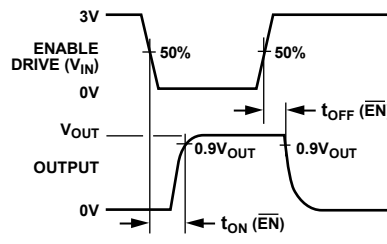
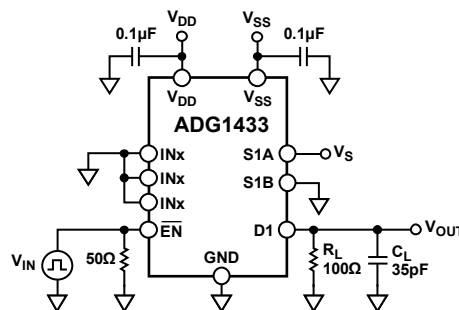

Figure 30. Enable Delay, $t_{ON}(\overline{EN})$, $t_{OFF}(\overline{EN})$

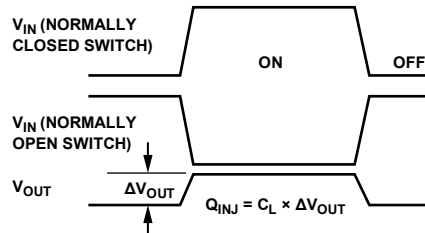
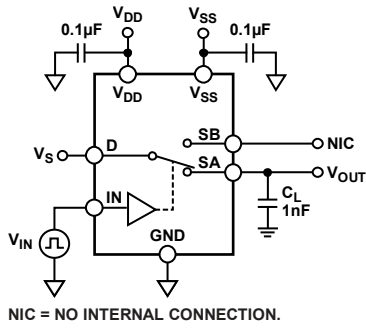
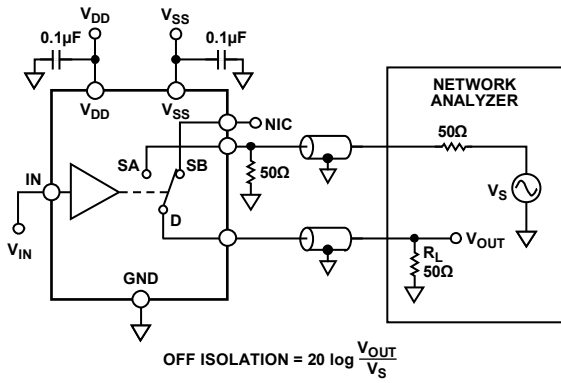

Figure 31. Charge Injection

06181-027



OFF ISOLATION = $20 \log \frac{V_{OUT}}{V_S}$

Figure 32. Off Isolation

06181-028

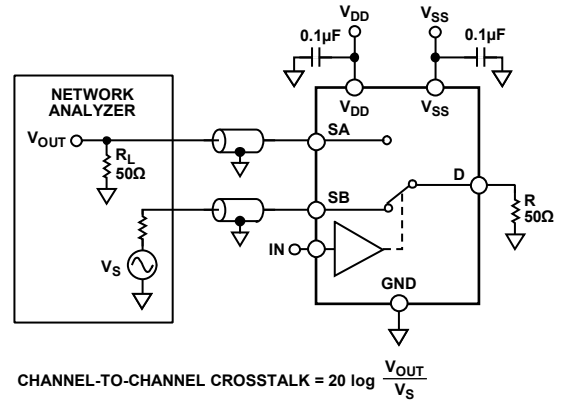

CHANNEL-TO-CHANNEL CROSSTALK = $20 \log \frac{V_{OUT}}{V_S}$

Figure 34. Channel-to-Channel Crosstalk

06181-030

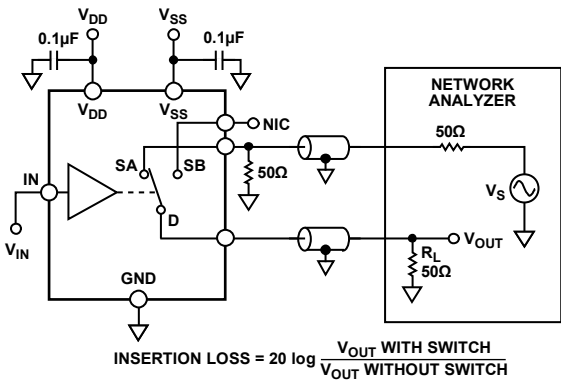

INSERTION LOSS = $20 \log \frac{V_{OUT \text{ WITH SWITCH}}}{V_{OUT \text{ WITHOUT SWITCH}}}$

Figure 33. Bandwidth

06181-029

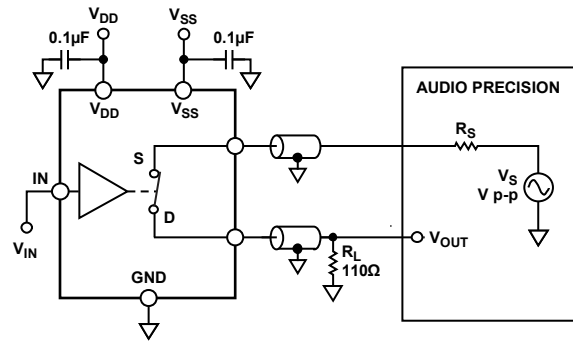

Figure 35. THD + Noise

06181-031

TERMINOLOGY

R_{ON}

Ohmic resistance between Terminal D and Terminal S.

ΔR_{ON}

The difference between the R_{ON} of any two channels.

$R_{FLAT(ON)}$

The difference between the maximum and minimum value of on resistance as measured.

I_S (Off)

Source leakage current when the switch is off.

I_D (Off)

Drain leakage current when the switch is off.

I_D, I_S (On)

Channel leakage current when the switch is on.

V_D (V_S)

Analog voltage on Terminal D and Terminal S.

C_S (Off)

Channel input capacitance for off condition.

C_D (Off)

Channel output capacitance for off condition.

C_D, C_S (On)

On switch capacitance.

C_{IN}

Digital input capacitance.

t_{ON} (\overline{EN})

Delay time between the 50% and 90% points of the digital input and switch on condition.

t_{OFF} (\overline{EN})

Delay time between the 50% and 90% points of the digital input and switch off condition.

t_{TRANS}

Delay time between the 50% and 90% points of the digital inputs and the switch on condition when switching from one address state to another.

t_{BBM}

Off time measured between the 80% point of both switches when switching from one address state to another.

V_{IL}

Maximum input voltage for Logic 0.

V_{IH}

Minimum input voltage for Logic 1.

I_{IL} (I_{IH})

Input current of the digital input.

I_{DD}

Positive supply current.

I_{SS}

Negative supply current.

Off Isolation

A measure of unwanted signal coupling through an off channel.

Charge Injection

A measure of the glitch impulse transferred from the digital input to the analog output during switching.

Bandwidth

The frequency at which the output is attenuated by 3 dB.

On Response

The frequency response of the on switch.

Total Harmonic Distortion + Noise (THD + N)

The ratio of the harmonic amplitude plus noise of the signal to the fundamental.

AC Power Supply Rejection Ratio (ACPSRR)

A measure of the ability of a device to avoid coupling noise and spurious signals that appear on the supply voltage pin to the output of the switch. The dc voltage on the device is modulated by a sine wave of 0.62 V p-p. The ratio of the amplitude of signal on the output to the amplitude of the modulation is the ACPSRR.

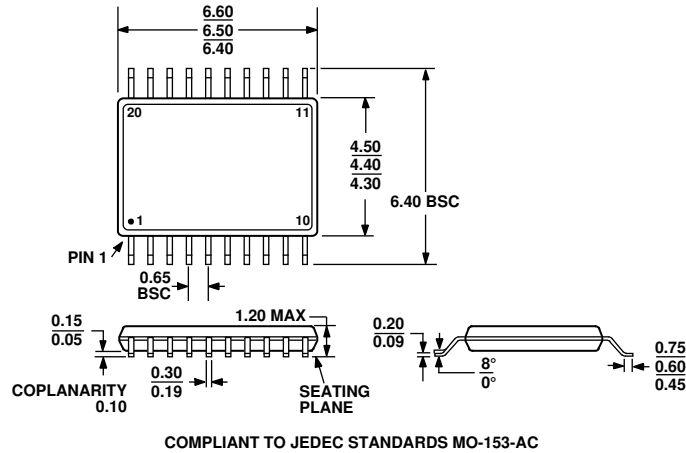

COMPLIANT TO JEDEC STANDARDS MO-153-AC

Figure 38. 20-Lead Thin Shrink Small Outline Package [TSSOP] (RU-20)

Dimensions shown in millimeters

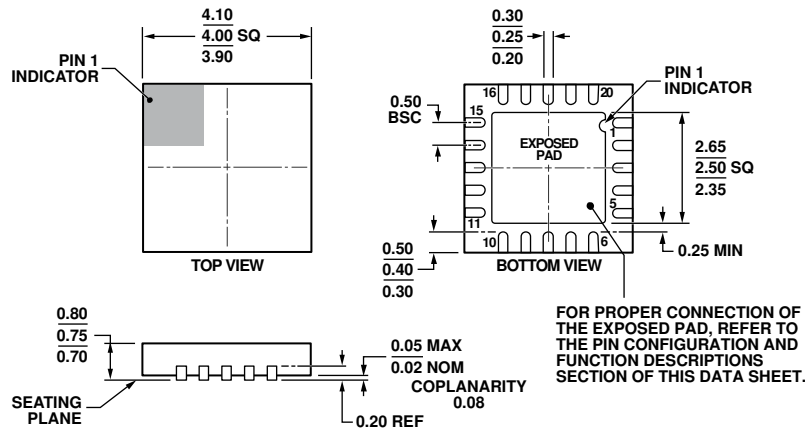

COMPLIANT TO JEDEC STANDARDS MO-220-WGGD.

Figure 39. 20-Lead Lead Frame Chip Scale Package [LFCS] 4 mm x 4 mm Body and 0.75 mm Package Height (CP-20-10)

Dimensions shown in millimeters

ORDERING GUIDE

Model ¹	Temperature Range	Description	EN Pin	Package Option
ADG1433YRUZ	-40°C to +125°C	16-Lead Thin Shrink Small Outline Package [TSSOP]	Yes	RU-16
ADG1433YRUZ-REEL	-40°C to +125°C	16-Lead Thin Shrink Small Outline Package [TSSOP]	Yes	RU-16
ADG1433YRUZ-REEL7	-40°C to +125°C	16-Lead Thin Shrink Small Outline Package [TSSOP]	Yes	RU-16
ADG1433YCPZ-REEL	-40°C to +125°C	16-Lead Lead Frame Chip Scale Package [LFCS]	Yes	CP-16-26
ADG1433YCPZ-REEL7	-40°C to +125°C	16-Lead Lead Frame Chip Scale Package [LFCS]	Yes	CP-16-26
ADG1434YRUZ	-40°C to +125°C	20-Lead Thin Shrink Small Outline Package [TSSOP]	No	RU-20
ADG1434YRUZ-REEL	-40°C to +125°C	20-Lead Thin Shrink Small Outline Package [TSSOP]	No	RU-20
ADG1434YRUZ-REEL7	-40°C to +125°C	20-Lead Thin Shrink Small Outline Package [TSSOP]	No	RU-20
ADG1434YCPZ-REEL	-40°C to +125°C	20-Lead Lead Frame Chip Scale Package [LFCS]	Yes	CP-20-10
ADG1434YCPZ-REEL7	-40°C to +125°C	20-Lead Lead Frame Chip Scale Package [LFCS]	Yes	CP-20-10

¹ Z = RoHS Compliant Part.

NOTES

NOTES

NOTES