

REVISIONS

REV	ECR	DESCRIPTION	DRAWN	DATE
1		ENGINEERING RELEASE	M. LARSEN	03/24/2023

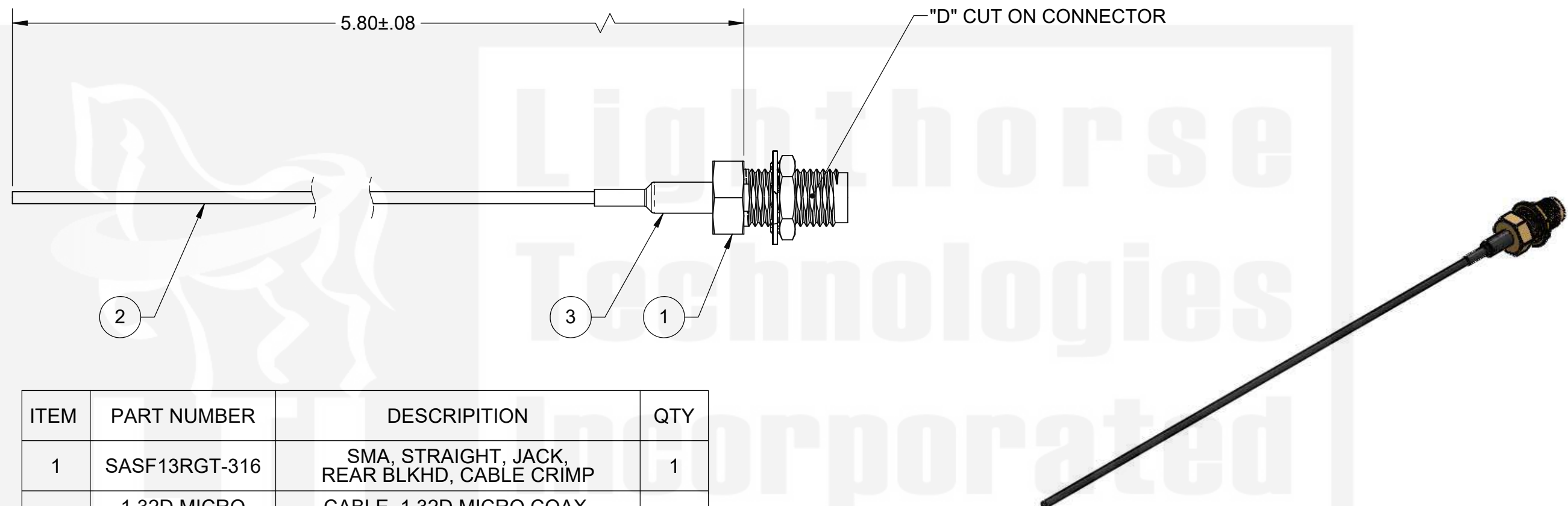

ITEM	PART NUMBER	DESCRIPTION	QTY
1	SASF13RGT-316	SMA, STRAIGHT, JACK, REAR BLKHD, CABLE CRIMP	1
2	1.32D MICRO COAX	CABLE, 1.32D MICRO COAX, DOUBLE SHIELDED BLACK	AR
3	HEAT SHRINK	.125 (1/8) DIA, .5 LENGTH, BLACK	1

DO NOT SCALE DRAWING
 TOLERANCES UNLESS OTHERWISE SPECIFIED
 DIMENSIONS ARE IN MILLIMETERS
 X = ±0.5
 X.X = ±0.25
 X.XX = ±0.13
 ANGLE = ±30'



Lighthouse Technologies
 San Diego, CA
 WWW.RFCONNECTOR.COM

TITLE: CABLE ASSEMBLY, CRIMP TO SMA, JACK, BLKHD, TO CUT CABLE USING 1.32D (DBL SHLD) MICRO COAX

CUSTOMER APPROVAL	
SIGN / DATE:	
ENG APPR.	
CHECKED	
DRAWN	M. LARSEN 03/24/2023
NAME	DATE

SIZE	PART/DWG. NO:	REV
B	CB1.32D-SAF3GT-C-5.8IN	1
SCALE: 4:1	FILE NAME	SHEET 1 OF 1

PROPRIETARY AND CONFIDENTIAL
 UNLESS OTHERWISE SPECIFIED: THIS DOCUMENT CONTAINS LIGHTHORSE TECHNOLOGIES INFORMATION. REPRODUCTION, USE, DISCLOSURE OR TRANSMITTAL OF ALL OR ANY PART OF THIS DOCUMENT IS PROHIBITED EXCEPT TO THE EXTENT APPROVED IN WRITING BY AN AUTHORIZED REPRESENTATIVE OF LIGHTHORSE TECHNOLOGIES. LIGHTHORSE TECHNOLOGIES RESERVES ALL RIGHTS UNDER PATENTS, TRADEMARKS, COPYRIGHTS AND TRADE SECRETS. COPY RIGHTS OF LIGHTHORSE TECHNOLOGIES 2011, ALL RIGHTS RESERVED.

