

MATERIAL NO.	ENGINEERING NO.	FINISHED LENGTH
1300068135	105001B21M050	16'5" +6.50"-0 (5M +165.1mm-0)
1300068136	105001B21M100	32'10" +12.50"-0 (10M +317.5mm-0)
1300068137	105001B21M200	65'7" +24.50"-0 (20M +622.3mm-0)
1300068138	105001B21M300	98'5" +24.50"-0 (30M +622.3mm-0)
1300068150	105001B21M020	6'7" +3.50"-0 (2M +88.9mm-0)
1300068220	105001B21M015	4'11" +2.19"-0 (1.5M +55.6mm-0)

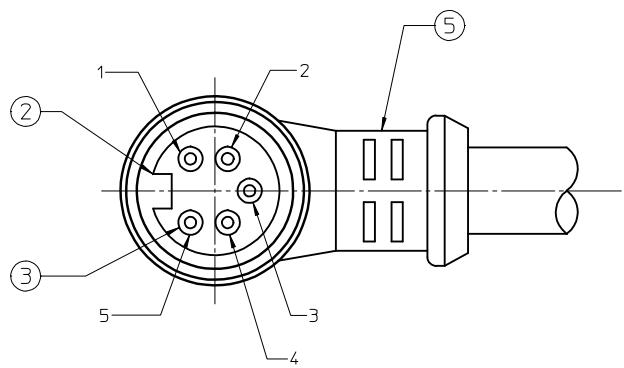
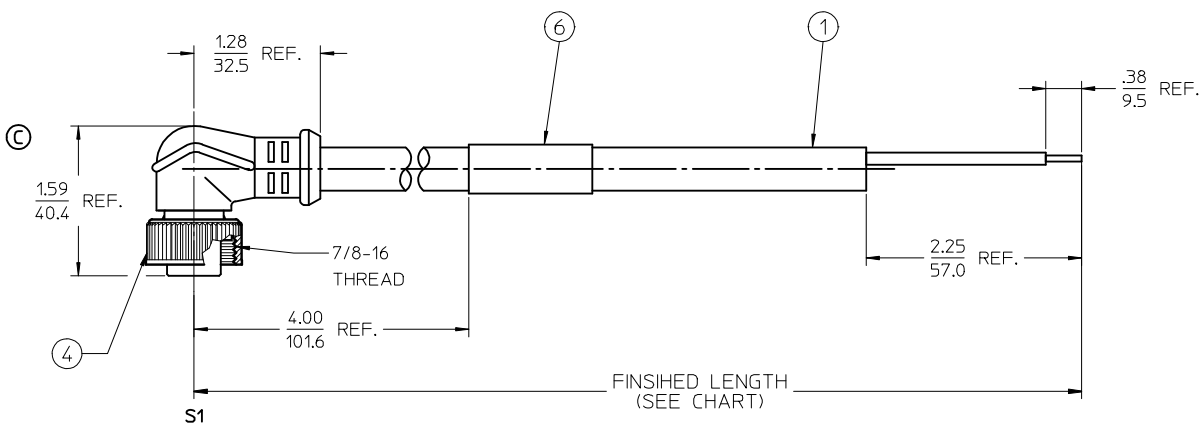

S1	Color
1	BLACK
2	BLUE
3	GREEN/YELLOW
4	BROWN
5	WHITE

WIRING DIAGRAM

- NOTES:
1. MATERIAL: SEE TABLE
  2. FINISHES: SEE TABLE
  3. ELECTRICAL SPECIFICATIONS  
VOLTAGE RATING: 300V AC/DC  
CURRENT RATING: 8 AMPS
  4. PROTECTION: IP67
  5. ASSEMBLY IS RoHS COMPLIANT BY EXEMPTION

FEMALE FACE VIEW  
SCALE: 2X

ITEM	QTY.	DESCRIPTION	MATERIAL	FINISH
6	1	WRAP LABEL	MYLAR	BLACK/YELLOW
5	1	OVERMOLD	PUR	BLACK
4	1	COUPLING RING-INT THREAD	ZINC DIE-CAST	BLACK
3	5	CONTACT SOCKET	Cu ALLOY	GOLD PLATED
2	1	INSERT, 5P	PUR	BLACK
1	A/R	CABLE 5/C, 1.5mm <sup>2</sup> (16 AWG)	PUR JACKET	GRAY

ADDED 1300068220 EC NO: IPGZ016-0209 DRWINGGUSTAFSON 2015/08/05 CHKDRSTONE 2015/10/09 APPR:	QUALITY SYMBOLS ▽=0 ▽=0	GENERAL TOLERANCES (UNLESS SPECIFIED) <table border="1"> <thead> <tr> <th></th> <th>mm</th> <th>INCH</th> </tr> </thead> <tbody> <tr> <td>4 PLACES</td> <td>± .005</td> <td>± .0005</td> </tr> <tr> <td>3 PLACES</td> <td>± .005</td> <td>± .0005</td> </tr> <tr> <td>2 PLACES</td> <td>± .005</td> <td>± .0005</td> </tr> <tr> <td>1 PLACE</td> <td>± 0.3</td> <td>± .012</td> </tr> <tr> <td>0 PLACE</td> <td>± .005</td> <td>± .0005</td> </tr> </tbody> </table>		mm	INCH	4 PLACES	± .005	± .0005	3 PLACES	± .005	± .0005	2 PLACES	± .005	± .0005	1 PLACE	± 0.3	± .012	0 PLACE	± .005	± .0005	DIMENSION STYLE IN/MM	SCALE 1:1	DESIGN UNITS INCH	THIRD ANGLE PROJECTION
		mm	INCH																					
	4 PLACES	± .005	± .0005																					
	3 PLACES	± .005	± .0005																					
2 PLACES	± .005	± .0005																						
1 PLACE	± 0.3	± .012																						
0 PLACE	± .005	± .0005																						
DRAWN BY RSTONE	DATE 2012/11/12	TITLE MINI CHANGE CABLE ASSY. 5P FP 90 DEGREE 1.5MM <sup>2</sup> (16 AWG) PUR																						
CHECKED BY K JOZWIK	DATE 2012/11/26	APPROVED BY JFMURPHY																						
DATE 2012/12/18	MATERIAL NO. SEE CHART	DOCUMENT NO. SD-130006-044	SHEET NO. 1 OF 1																					