

PART NO.	JLL-301	WIRE	SCALE	1 : 1
DESCRIPTION	SJT#16*3C 60C SHIELDED		UNIT:	mm
DWG No.	800-1601-0-SJT0-BL-00200			

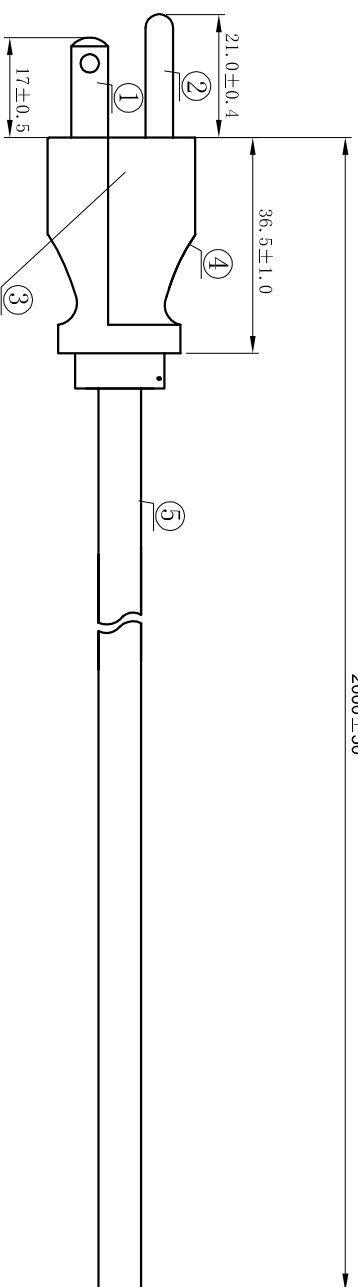

2000±50

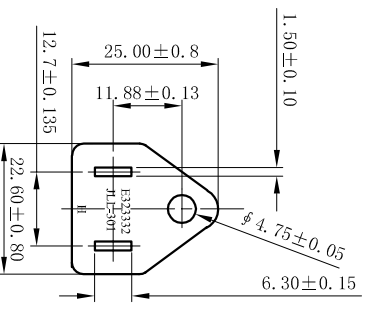
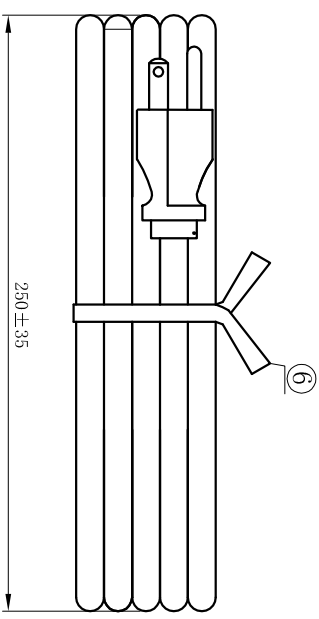
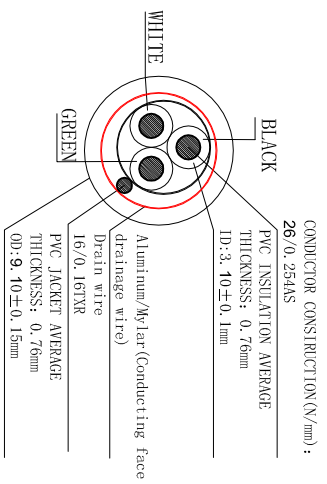

- NOTES:
- 1) JACKET COLOR: BLACK
 - 2). E-GREEN; L-BLACK; N-WHITE
- TESTING:
- 1) 100% OPEN & SHORT TESTING
 - 2) INSULATION RESISTANCE: 100M ohm (min)
 - 3) VOLTAGE: DC500V/1min
 - 4) ROHS COMPLIANT

NO.	SPECIFICATION	COLOUR	MATERIAL	AMOUNT
①	Load terminals 98861	Silver	Cu	2P
②	Grounding terminal 97475	Silver	Cu	1P
③	Model aircraft 8661AW-3P	WHITE	PBT	1PCS
④	Plug JLL-301	BLACK	PVC Cu	1PCS
⑤	Wire SJT 16AWG/3C 60°	BLACK	PVC Cu	1PCS
⑥	Ties	BLACK		1PCS

Printing the contents of wire The use of printing ink replenish Wire

E243929 (UL) SJT 3X16AWG(1.31mm²) VW-1 SHIELDED 60°C 300V CSA 228191 SJ
 T 3X16AWG(1.31mm²) FT2 SHIELDED 60°C 300V -1P-