

THIS DRAWING IS UNPUBLISHED. RELEASED FOR PUBLICATION
 © COPYRIGHT - By - ALL RIGHTS RESERVED.

REVISIONS					
P	LTR	DESCRIPTION	DATE	DWN	APVD
H		REVISED PER ECR-15-017683	07DEC2015	NL	RS

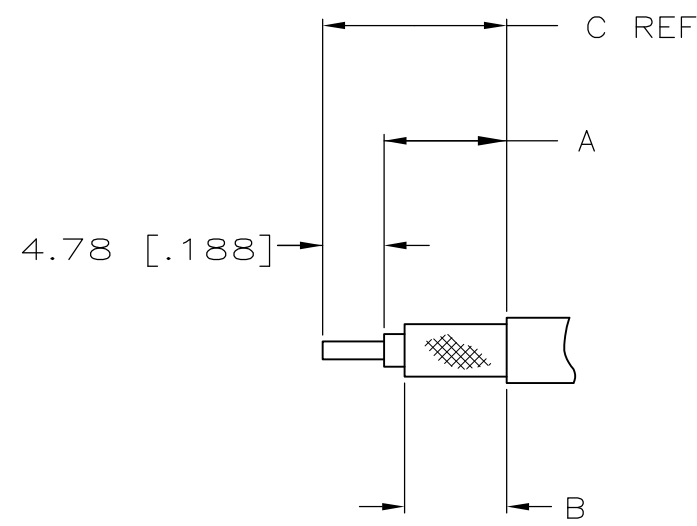

RECOMMENDED STRIP LENGTH FOR STANDARD COAX CABLE

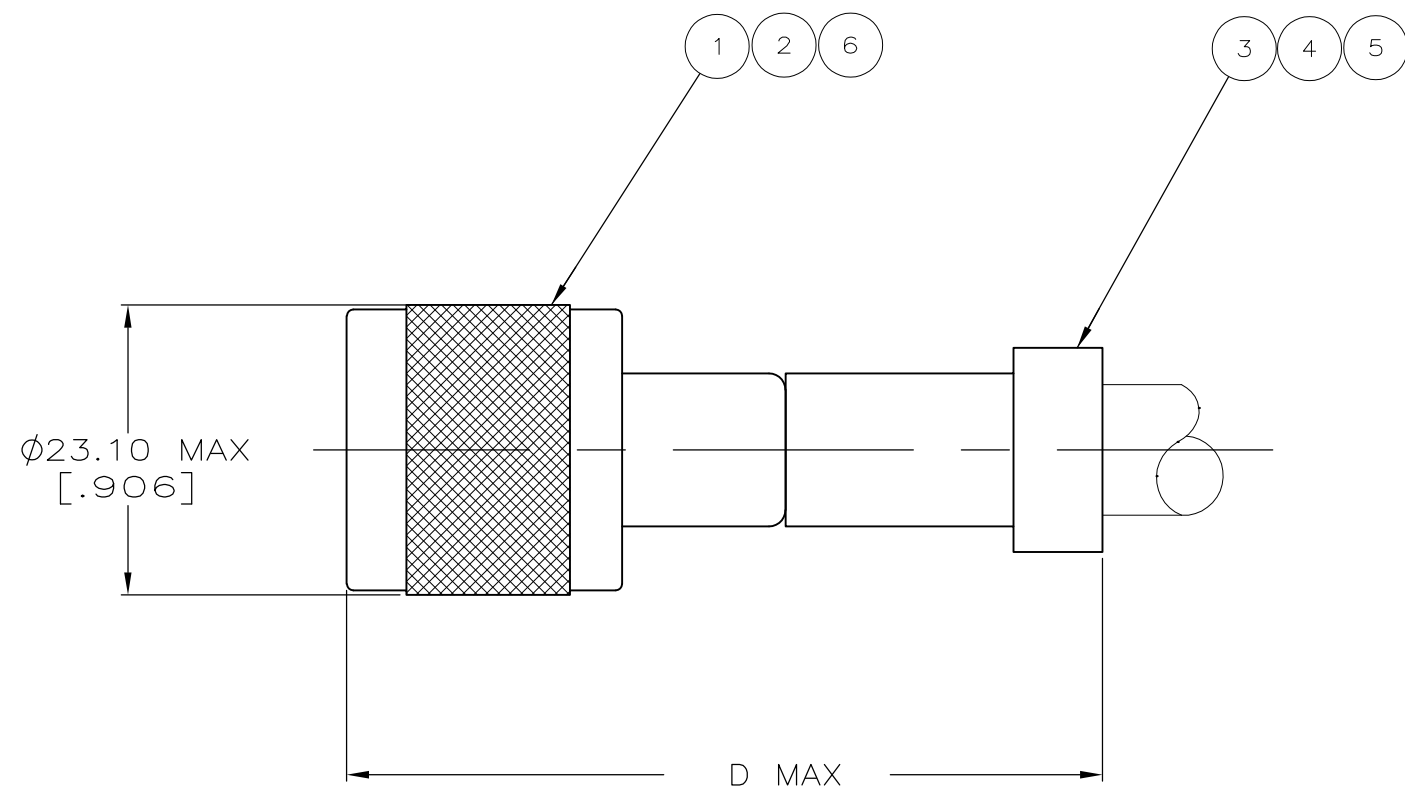
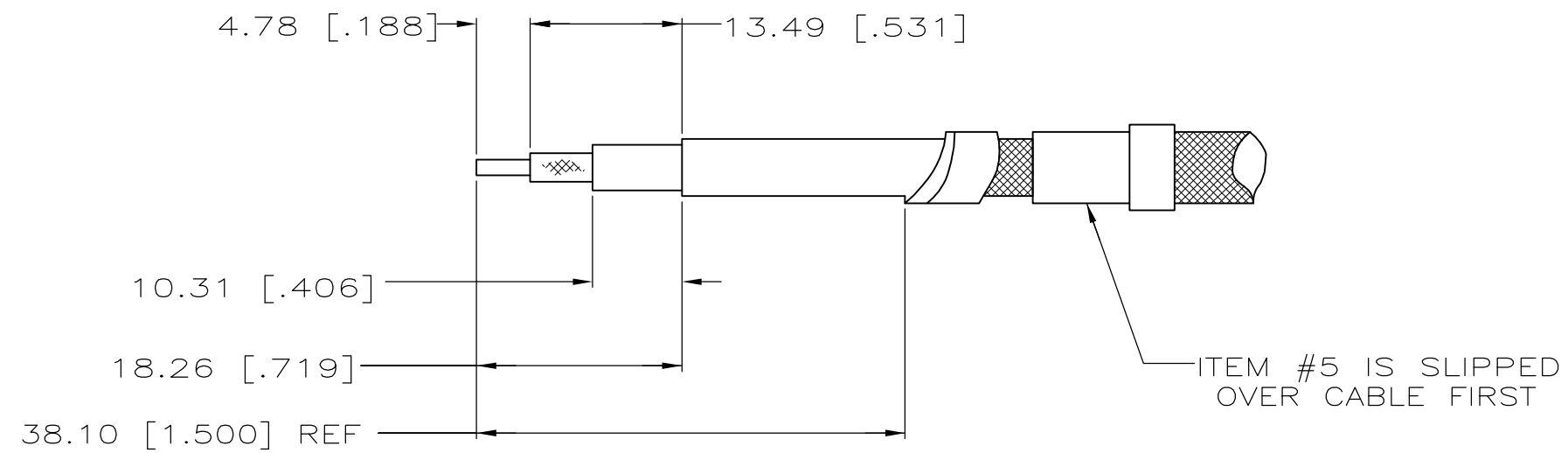

RECOMMENDED STRIP LENGTH FOR ARMOR CABLE

- 1 FOR USE WITH: RG-149/U, & 391/U STANDARD CABLE.
- 2 FOR USE WITH: RG-150/U, & 392/U ARMOR CABLE.
- 3 USE CRIMPING TOOL: 220015-1 FOR STANDARD CABLE.
- 4 USE CRIMPING TOOLS: 220015-1, & 220042-1 FOR ARMOR CABLE.
- 5 USE CRIMPING TOOL: 220045-3
- 6 USE CRIMPING TOOL: 220045-2
- 7. SEE I.S.: 2338
- 8 P/N 225744-4 IS RATED AT 2300 VAC.

OBSOLETE	RG-142 B/U CABLE 6	225592-2	-	-	225560-2	1-225343-2	227560-1	1-225744-5
	1 2 3 4	-	225326-2	225325-2	1-331987-9	226719-2	225745-3	225744-8
OBSOLETE	RG-302/U CABLE 5	225592-3	-	-	1-225560-5	1-225343-0	227560-2	225744-6
8 OBSOLETE	RG-59/U CABLE 5	225592-3	-	-	225560-3	1-225343-0	227560-2	225744-4
	1 2 3 4	-	9-225326-0	9-225325-0	9-331987-5	226719-2	9-225745-0	225744-3
OBSOLETE	RG-9/U,9A/U,9B/U,& 214/U CABLE 3	332022	-	-	331987	225753-2	225745-1	225744-2
	FOR USE WITH	6 SEAL QTY=1	5 FERRULE ARMOR QTY=1	4 FERRULE BRAID QTY=1	3 FERRULE QTY=1	2 CONTACT QTY=1	1 PLUG ASSY QTY=1	PART NUMBER

53.59[2.110]	17.48[.688]	9.53[.375]	12.70[.500]	1-225744-5
57.94[2.281]	22.25[.876]	12.70[.500]	17.48[.688]	225744-8
53.59[2.110]	14.30[.563]	6.35[.250]	9.53[.375]	225744-6
53.59[2.110]	14.30[.563]	7.92[.312]	9.53[.375]	225744-4
57.94[2.281]	22.25[.876]	12.70[.500]	17.48[.688]	225744-3
57.94[2.281]	22.25[.876]	12.70[.500]	17.48[.688]	225744-2
D	C	B	A	PART NUMBER

THIS DRAWING IS A CONTROLLED DOCUMENT.

DWN S.D.KOHL 06-05-91				
CHK M. SNEED 10-1-91				
APVD R. HENRY 10-1-91				
NAME PLUG, WEATHERPROOF, SERIES HN				
PRODUCT SPEC 108-12066	SIZE A2	CAGE CODE 00779	DRAWING NO C=225744	RESTRICTED TO -
APPLICATION SPEC	WEIGHT -	SCALE 2:1	SHEET 1 of 1	REV H
MATERIAL -	FINISH -	CUSTOMER DRAWING		