

10

9

8

7

6

5

4

3

2

1

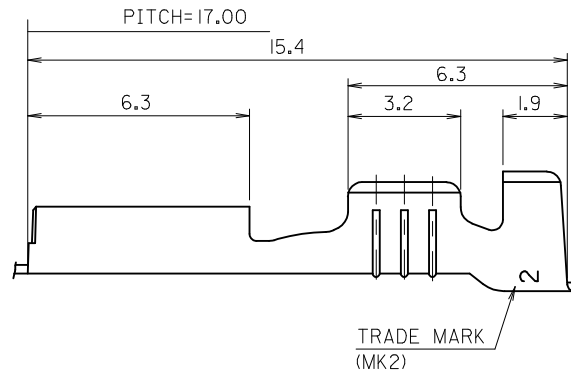
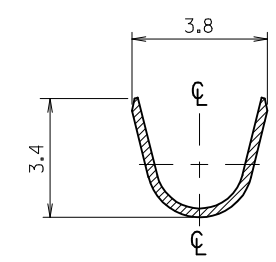
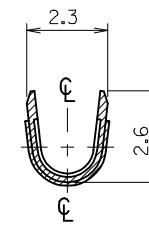
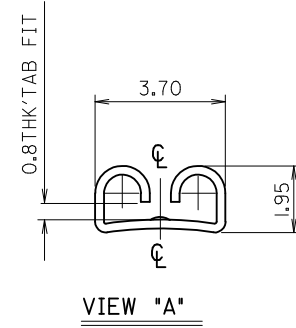
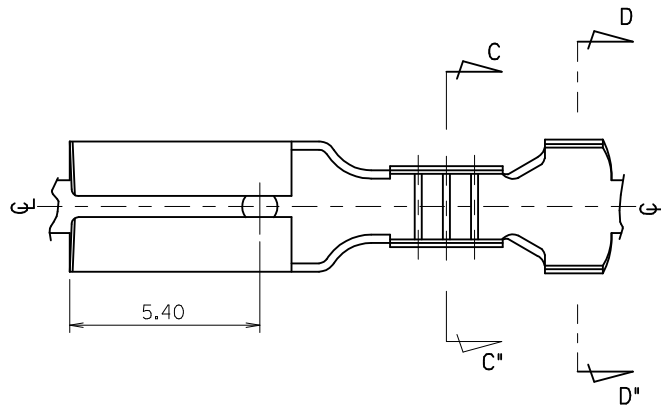

SECTION: C-C'

SECTION: D-D'

NOTES.

1. MATERIAL : BRASS
2. FINISH : 35711-1100 : UNPLATED
35711-1110 : © PRE-TIN PLATED
0.8~1.8 μm TIN PLATING
OVERALL 0.3~0.8μm COPPER PLATING
3. PRODUCT SPECIFICATION : PS-35702-001
PS-35827-001
4. MATES WITH : 0.8t TAB
5. APPLICABLE WIRE RANGE : AWG #22~#20



REVISED EC NO: KOR2009-0111 DRAWN: JHPARK01 2009/01/30 CHKD: WY YANG 2009/01/30 APPR: YUNSTIKKIM 2009/01/30	QUALITY SYMBOLS ▽=0 ◻=0	GENERAL TOLERANCES (UNLESS SPECIFIED)		DIMENSION STYLE MM ONLY		SCALE 8:1	DESIGN UNITS METRIC	THIRD ANGLE PROJECTION		
			mm	INCH	DRAWN BY WY YANG	DATE 1993/04/15	TITLE .110 SLIP-ON RECEPTACLE			
		4 PLACES	± ---	± ---	CHECKED BY BK CHOI	DATE 1993/04/15				
		3 PLACES	± ---	± ---	APPROVED BY CW LEE	DATE 1993/04/15	MATERIAL NO. SD-35711-11*0			
			2 PLACES	± ---	± ---	DOCUMENT NO.		SHEET NO.		
			1 PLACE	± 0.30	± ---	MATERIAL NO.		1 OF 01		
			ANGULAR ± ---°		SEE NOTE		MATERIAL NO.			
			DRAFT WHERE APPLICABLE MUST REMAIN WITHIN DIMENSIONS		SIZE A3		MATERIAL NO.			

9

8

7

6

5

4

3

2

1