

13	12	11	10	9	8	7	6	5	4	3	2	1
PART NUMBER	ENGINEERING NUMBER	FINISH LENGTH										
1300060183	102002A03F010	1' +.75" -0 [0.3M +19.1 -0]										
1300060184	102002A03F120	12' +3.50" -0 [3.7M +88.9 -0]										

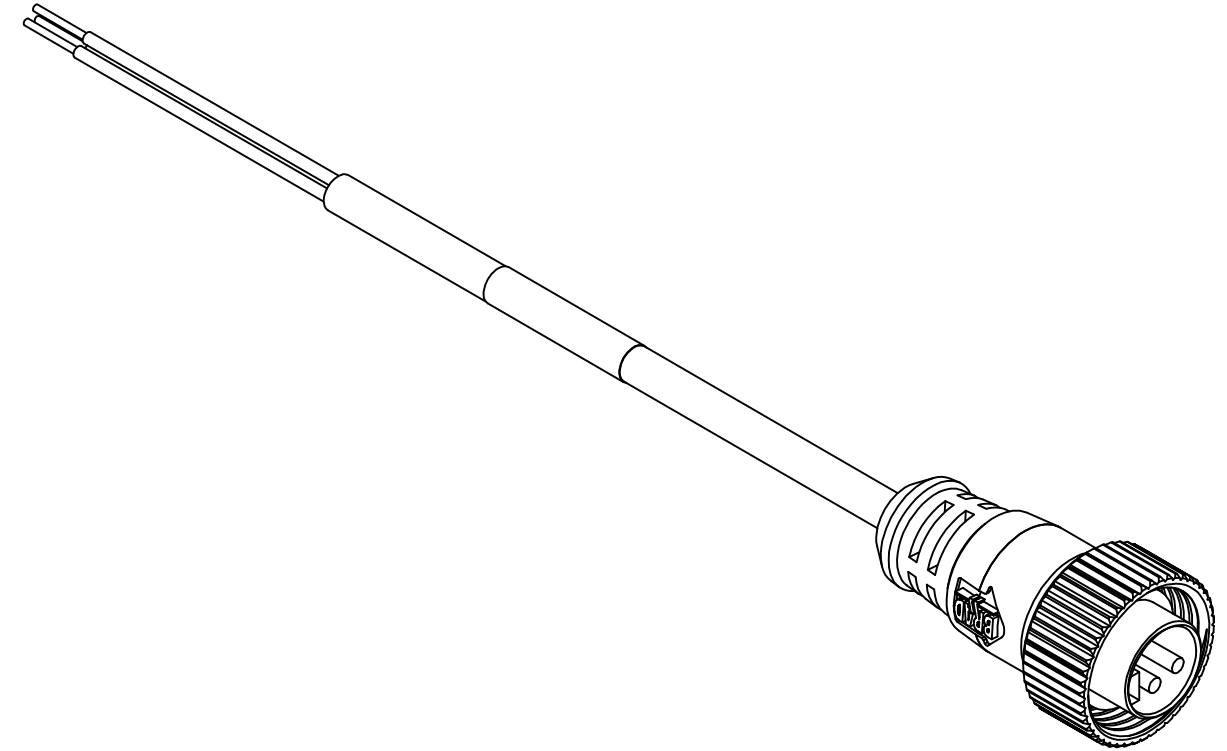

NOTE

- 1) MATERIAL: SEE TABLE
- 2) FINISHES: SEE TABLE
- 3) WRAP LABEL IS MARKED WITH P/N, DATE CODE, VOLTAGE & AMPERAGE
- 4) MATES WITH: MINI CHANGE, 2 POLE RECEPTACLE
- 5) ELECTRICAL DATA:
 INLINE CORDSET
 MALE A-SIZE WITH FLYING LEADS
 18AWG UNSHIELDED
 POLES: 2
 MAX. VOLTAGE: 300V
 MAX. CURRENT 10A
 PROTECTION IP67
 TEMPERATURE RANGE: -20°C TO 105°C
- 6) PACKAGING:
 CABLE ASSEMBLIES ARE BAGGED SEPERATELY
 IN POLY BAGS WITH BAR CODE LABEL ATTACHED
 TO OUTSIDE OF BAG.
- 7) ASSEMBLY IS RoHS COMPLIANT.
- 8) CERTIFICATION
 CSA CERTIFIED, FILE NO. LR6837

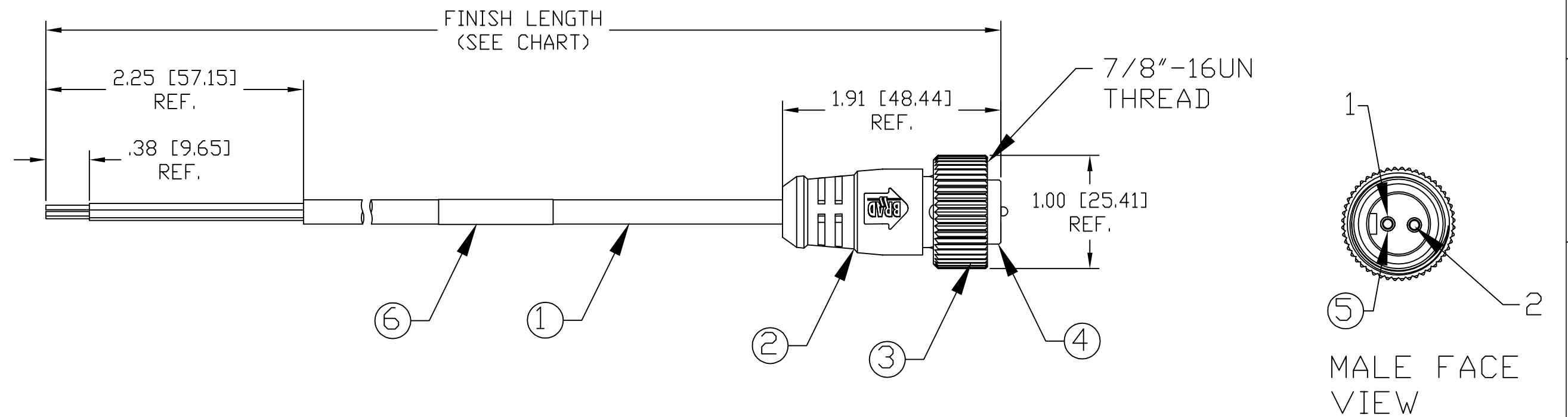

P1

1	BROWN
2	BLUE

WIRING DIAGRAM

6	1	LABEL	PLASTIC FILM	BLACK/YELLOW
5	2	CONTACT PIN	COPPER ALLOY	GOLD PLATED
4	1	INSERT	PVC	YELLOW
3	1	COUPLING NUT	ZINC DIE CAST	BLACKE-COATED
2	1	OVERMOLD	PVC	YELLOW
1	1	CABLE, 18AWG-2	PVC	YELLOW
ITEM	QTY.	DESCRIPTION	MATERIAL	FINISH

RELEASE EC NO: WNA2010-0260 DRWN: BWOODMAN 10/9/09 CH'KD: BWOODMAN APPR: JFMURPHY 2009/10/23	DESCRIPTION REV A	QUALITY SYMBOL	GENERAL TOLERANCES (UNLESS SPECIFIED)	DIMENSION STYLE	SCALE	DESIGN UNITS	THIRD ANGLE PROJECTION	
		$\nabla=0$ $\sphericalangle=0$	4 PLACES ±--- 3 PLACES ±.005 2 PLACES ±.013 1 PLACE ±.025	IN/MM mm INCH ±--- ±--- ±.005 ±.005 ±.013 ±.010 ±.025 ±.020	DRAWN BY DATE KJOZWIK 2009/10/09 CHECKED BY DATE BWOODMAN 2009/10/09 APPROVED BY DATE JFMURPHY 2009/10/23	1:1	INCH	
		ANGULAR ±1/2° DRAFT WHERE APPLICABLE MUST REMAIN WITHIN DIMENSIONS	MATERIAL NO. SEE CHART SIZE C	TITLE MINI CHANGE ASSEMBLY 2-POLE MALE ST 18/2 AWG PVC MOLEX INCORPORATED DOCUMENT NO. SD-130006-019 SHEET NO. 1 OF 1				
		THIS DRAWING CONTAINS INFORMATION THAT IS PROPRIETARY TO MOLEX INCORPORATED AND SHOULD NOT BE USED WITHOUT WRITTEN PERMISSION						