



PRELIMINARY

ICS840024I

FEMTOCLOCKS™ CRYSTAL-TO-LVCMOS/LVTTL FREQUENCY SYNTHESIZER

GENERAL DESCRIPTION

The ICS840024I is a 4 output LVCMOS/LVTTL Synthesizer optimized to generate Ethernet reference clock frequency and is a member of the HiPerClocks™ family of high performance clock solutions from ICS. The ICS840024I uses IDT's 3rd generation low phase noise VCO technology and can achieve 1ps or lower typical random rms phase jitter, easily meeting Ethernet jitter requirements. The ICS840024I is packaged in a small 20-pin TSSOP package.

FEATURES

- Four LVCMOS/LVTTL outputs, 15Ω typical output impedance
- Selectable crystal oscillator interface or LVCMOS single-ended input
- Supports the following output frequency: 125MHz
- RMS phase jitter @ 125MHz (1.875MHz - 20MHz): 0.60ps (typical)
- Output supply modes:
Core/Output
3.3V/3.3V
3.3V/2.5V
2.5V/2.5V
- -40°C to 85°C ambient operating temperature
- Available in both standard (RoHS 5) and lead-free (RoHS 6) packages

BLOCK DIAGRAM

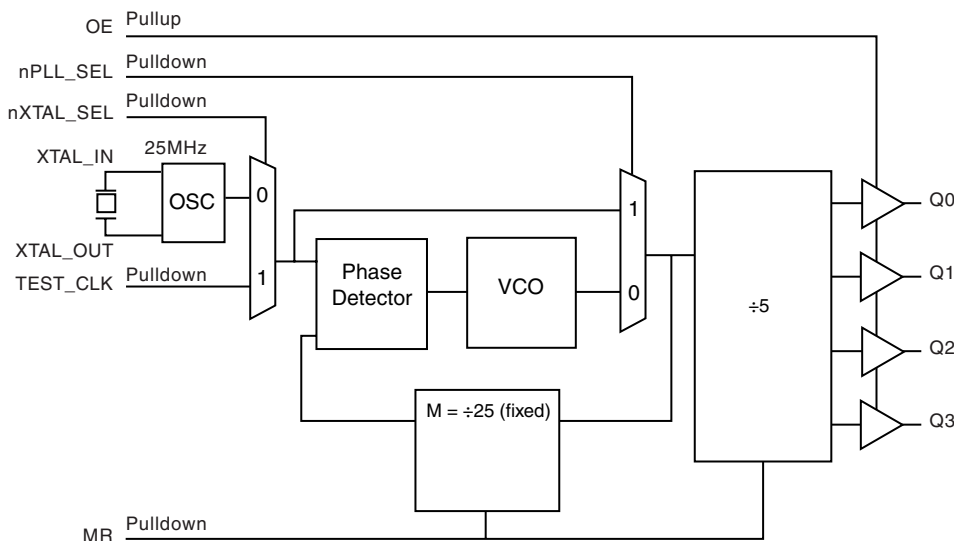

PIN ASSIGNMENT

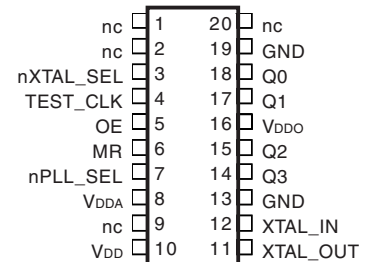

ICS840024I

20-Lead TSSOP

6.5mm x 4.4mm x 0.92mm
package body
G Package
Top View

The Preliminary Information presented herein represents a product in pre-production. The noted characteristics are based on initial product characterization and/or qualification. Integrated Device Technology, Incorporated (IDT) reserves the right to change any circuitry or specifications without notice.



PRELIMINARY

ICS840024I
FEMTOCLOCKS™ CRYSTAL-TO-
LVC MOS/LVTTL FREQUENCY SYNTHESIZER

TABLE 1. PIN DESCRIPTIONS

Number	Name	Type		Description
1, 2, 9, 20	nc	Unused		No connect.
3	nXTAL_SEL	Input	Pulldown	Selects between the crystal or TEST_CLK inputs as the PLL reference source. When HIGH, selects TEST_CLK. When LOW, selects XTAL inputs. LVC MOS/LVTTL interface levels.
4	TEST_CLK	Input	Pulldown	Single-ended LVC MOS/LVTTL clock input.
5	OE	Input	Pullup	Output enable pin. When HIGH, the outputs are active. When LOW, the outputs are in a high impedance state. LVC MOS/LVTTL interface levels.
6	MR	Input	Pulldown	Active HIGH Master Reset. When logic HIGH, the internal dividers are reset causing the outputs to go low. When logic LOW, the internal dividers and the outputs are enabled. LVC MOS/LVTTL interface levels.
7	nPLL_SEL	Input	Pulldown	PLL Bypass. When LOW, the output is driven from the VCO output. When HIGH, the PLL is bypassed and the output frequency = reference clock frequency/N output divider. LVC MOS/LVTTL interface levels.
8	V _{DDA}	Power		Analog supply pin.
10	V _{DD}	Power		Core supply pin.
11, 12	XTAL_OUT, XTAL_IN	Input		Crystal oscillator interface. XTAL_OUT is the output. XTAL_IN is the input.
13, 19	GND	Power		Power supply ground.
14, 15, 17, 18	Q3, Q2, Q1, Q0	Output		Single-ended clock outputs. LVC MOS/LVTTL interface levels. 15Ω typical output impedance.
16	V _{DDO}	Power		Output supply pin.

NOTE: *Pullup* and *Pulldown* refer to internal input resistors. See Table 2, Pin Characteristics, for typical values.

TABLE 2. PIN CHARACTERISTICS

Symbol	Parameter	Test Conditions	Minimum	Typical	Maximum	Units
C _{IN}	Input Capacitance			4		pF
C _{PD}	Power Dissipation Capacitance	V _{DD} , V _{DDA} , V _{DDO} = 3.465V		TBD		pF
		V _{DD} , V _{DDA} = 3.465V, V _{DDO} = 2.625V		TBD		pF
		V _{DD} , V _{DDA} , V _{DDO} = 2.625V		TBD		pF
R _{PULLUP}	Input Pullup Resistor			51		KΩ
R _{PULLDOWN}	Input Pulldown Resistor			51		KΩ
R _{OUT}	Output Impedance			15		Ω



PRELIMINARY

ICS840024I
FEMTOCLOCKS™ CRYSTAL-TO-LVCMOS/LVTTL FREQUENCY SYNTHESIZER

ABSOLUTE MAXIMUM RATINGS

Supply Voltage, V_{DD}	4.6V
Inputs, V_i	-0.5V to $V_{DD} + 0.5V$
Outputs, V_o	-0.5V to $V_{DD} + 0.5V$
Package Thermal Impedance, θ_{JA}	73.2°C/W (0 lfm)
Storage Temperature, T_{STG}	-65°C to 150°C

NOTE: Stresses beyond those listed under Absolute Maximum Ratings may cause permanent damage to the device. These ratings are stress specifications only. Functional operation of product at these conditions or any conditions beyond those listed in the *DC Characteristics* or *AC Characteristics* is not implied. Exposure to absolute maximum rating conditions for extended periods may affect product reliability.

TABLE 3A. POWER SUPPLY DC CHARACTERISTICS, $V_{DDD} = V_{DDA} = V_{DDO} = 3.3V \pm 5\%$, $T_A = -40^\circ C$ TO $85^\circ C$

Symbol	Parameter	Test Conditions	Minimum	Typical	Maximum	Units
V_{DD}	Core Supply Voltage		3.135	3.3	3.465	V
V_{DDA}	Analog Supply Voltage		3.135	3.3	3.465	V
V_{DDO}	Output Supply Voltage		3.135	3.3	3.465	V
I_{DD}	Power Supply Current			75		mA
I_{DDA}	Analog Supply Current			6		mA
I_{DDO}	Output Supply Current			3		mA

TABLE 3B. POWER SUPPLY DC CHARACTERISTICS, $V_{DD} = V_{DDA} = 3.3V \pm 5\%$, $V_{DDO} = 2.5V \pm 5\%$, $T_A = -40^\circ C$ TO $85^\circ C$

Symbol	Parameter	Test Conditions	Minimum	Typical	Maximum	Units
V_{DD}	Core Supply Voltage		3.135	3.3	3.465	V
V_{DDA}	Analog Supply Voltage		3.135	3.3	3.465	V
V_{DDO}	Output Supply Voltage		2.375	2.5	2.625	V
I_{DD}	Power Supply Current			75		mA
I_{DDA}	Analog Supply Current			6		mA
I_{DDO}	Output Supply Current			3		mA

TABLE 3C. POWER SUPPLY DC CHARACTERISTICS, $V_{DDD} = V_{DDA} = V_{DDO} = 2.5V \pm 5\%$, $T_A = -40^\circ C$ TO $85^\circ C$

Symbol	Parameter	Test Conditions	Minimum	Typical	Maximum	Units
V_{DD}	Core Supply Voltage		2.375	2.5	2.625	V
V_{DDA}	Analog Supply Voltage		2.375	2.5	2.625	V
V_{DDO}	Output Supply Voltage		2.375	2.5	2.625	V
I_{DD}	Power Supply Current			70		mA
I_{DDA}	Analog Supply Current			6		mA
I_{DDO}	Output Supply Current			3		mA



PRELIMINARY

ICS840024I
FEMTOCLOCKS™ CRYSTAL-TO-
LVC MOS/LVTTL FREQUENCY SYNTHESIZER

TABLE 3D. LVC MOS/LVTTL DC CHARACTERISTICS, $V_{DD} = V_{DDA} = V_{DDO} = 3.3V \pm 5\%$ OR $2.5V \pm 5\%$, OR $V_{DD} = V_{DDA} = 3.3V \pm 5\%$, $V_{DDO} = 2.5V \pm 5\%$, $T_A = -40^\circ\text{C}$ TO 85°C

Symbol	Parameter	Test Conditions	Minimum	Typical	Maximum	Units
V_{IH}	Input High Voltage	OE, MR, nPLL_SEL, nXTAL_SEL, TEST_CLK	2		$V_{DD} + 0.3$	V
			2		$V_{DD} + 0.3$	V
V_{IL}	Input Low Voltage	OE, MR, nPLL_SEL, nXTAL_SEL, TEST_CLK	-0.3		0.8	V
			-0.3		1.3	V
I_{IH}	Input High Current	OE	$V_{DD} = V_{IN} = 3.465V$ or $2.625V$		5	μA
		nPLL_SEL, MR, nXTAL_SEL, TEST_CLK	$V_{DD} = V_{IN} = 3.465V$ or $2.625V$		150	μA
I_{IL}	Input Low Current	OE	$V_{DD} = 3.465V$ or $2.625V$, $V_{IN} = 0V$	-150		μA
		nPLL_SEL, MR, nXTAL_SEL, TEST_CLK	$V_{DD} = 3.465V$ or $2.625V$, $V_{IN} = 0V$	-5		μA
V_{OH}	Output High Voltage; NOTE 1		$V_{DDO} = 3.3V \pm 5\%$	2.6		V
			$V_{DDO} = 2.5V \pm 5\%$	1.8		V
V_{OL}	Output Low Voltage; NOTE 1		$V_{DDO} = 3.3V$ or $2.5V \pm 5\%$		0.5	V

NOTE 1: Outputs terminated with 50Ω to $V_{DDO}/2$. See Parameter Measurement Information, Output Load Test Circuit.

TABLE 4. CRYSTAL CHARACTERISTICS

Parameter	Test Conditions	Minimum	Typical	Maximum	Units
Mode of Oscillation		Fundamental			
Frequency			25		MHz
Equivalent Series Resistance (ESR)				50	Ω
Shunt Capacitance				7	pF

NOTE: Characterized using an 18pf parallel resonant crystal.



PRELIMINARY

ICS840024I
FEMTOCLOCKS™ CRYSTAL-TO-
LVC MOS/LVTTL FREQUENCY SYNTHESIZER

TABLE 5A. AC CHARACTERISTICS, $V_{DD} = V_{DDA} = V_{DDO} = 3.3V \pm 5\%$, $T_A = -40^\circ C$ TO $85^\circ C$

Symbol	Parameter	Test Conditions	Minimum	Typical	Maximum	Units
f_{OUT}	Output Frequency			125		MHz
$t_{sk(o)}$	Output Skew; NOTE 1, 3			TBD		ps
$f_{jit}(\emptyset)$	RMS Phase Jitter (Random); NOTE 2	Intergration Range 1.875MHz - 20MHz		0.60		ps
t_L	PLL Lock Time			TBD		ms
t_R / t_F	Output Rise/Fall Time	20% to 80%		400		ps
odc	Output Duty Cycle			50		%

NOTE 1: Defined as skew between outputs at the same supply voltages and with equal load conditions. Measured at $V_{DDO}/2$.

NOTE 2: Please refer to the Phase Noise Plot.

NOTE 3: This parameter is defined in accordance with JEDEC Standard 65.

TABLE 5B. AC CHARACTERISTICS, $V_{DD} = V_{DDA} = 3.3V \pm 5\%$, $V_{DDO} = 2.5V \pm 5\%$, $T_A = -40^\circ C$ TO $85^\circ C$

Symbol	Parameter	Test Conditions	Minimum	Typical	Maximum	Units
f_{OUT}	Output Frequency			125		MHz
$t_{sk(o)}$	Output Skew; NOTE 1, 3			TBD		ps
$f_{jit}(\emptyset)$	RMS Phase Jitter (Random); NOTE 2	Intergration Range 1.875MHz - 20MHz		0.55		ps
t_L	PLL Lock Time			TBD		ms
t_R / t_F	Output Rise/Fall Time	20% to 80%		400		ps
odc	Output Duty Cycle			50		%

NOTE 1: Defined as skew between outputs at the same supply voltages and with equal load conditions. Measured at $V_{DDO}/2$.

NOTE 2: Please refer to the Phase Noise Plot.

NOTE 3: This parameter is defined in accordance with JEDEC Standard 65.

TABLE 5C. AC CHARACTERISTICS, $V_{DD} = V_{DDA} = V_{DDO} = 2.5V \pm 5\%$, $T_A = -40^\circ C$ TO $85^\circ C$

Symbol	Parameter	Test Conditions	Minimum	Typical	Maximum	Units
f_{OUT}	Output Frequency			125		MHz
$t_{sk(o)}$	Output Skew; NOTE 1, 3			TBD		ps
$f_{jit}(\emptyset)$	RMS Phase Jitter (Random); NOTE 2	Intergration Range 1.875MHz - 20MHz		0.50		ps
t_L	PLL Lock Time			TBD		ms
t_R / t_F	Output Rise/Fall Time	20% to 80%		400		ps
odc	Output Duty Cycle			50		%

NOTE 1: Defined as skew between outputs at the same supply voltages and with equal load conditions. Measured at $V_{DDO}/2$.

NOTE 2: Please refer to the Phase Noise Plot.

NOTE 3: This parameter is defined in accordance with JEDEC Standard 65.



PRELIMINARY

ICS840024I

FEMTOCLOCKS™ CRYSTAL-TO-LVCMOS/LVTTL FREQUENCY SYNTHESIZER

TYPICAL PHASE NOISE AT 125MHz (3.3V/3.3V)

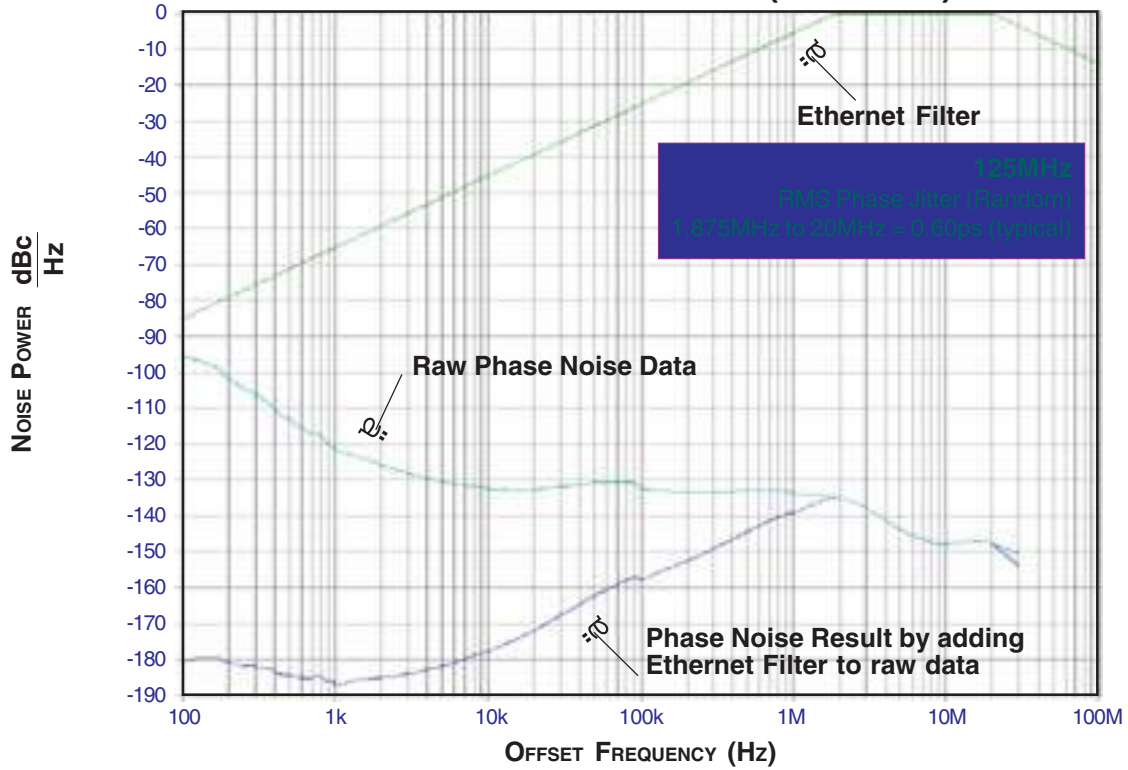

TYPICAL PHASE NOISE AT 125MHz (3.3V/2.5V)

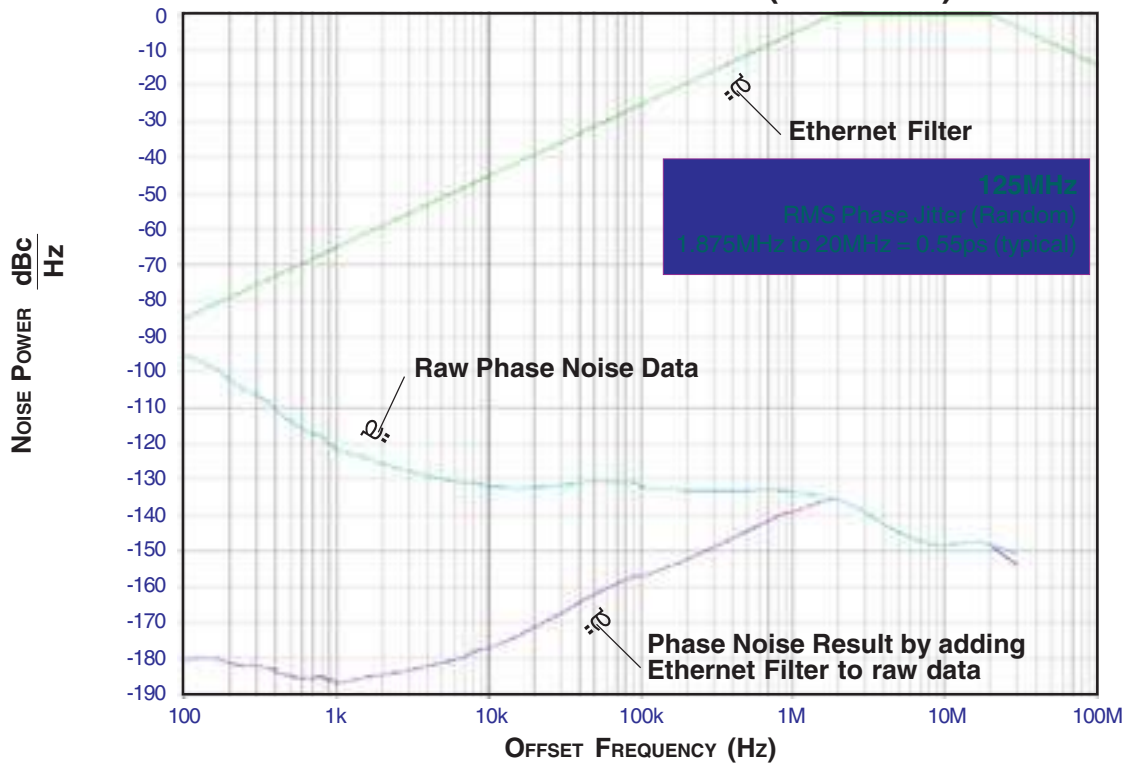



PRELIMINARY

ICS840024I
FEMTOCLOCKS™ CRYSTAL-TO-
LVCMOS/LVTTL FREQUENCY SYNTHESIZER

TYPICAL PHASE NOISE AT 125MHz (2.5V/2.5V)

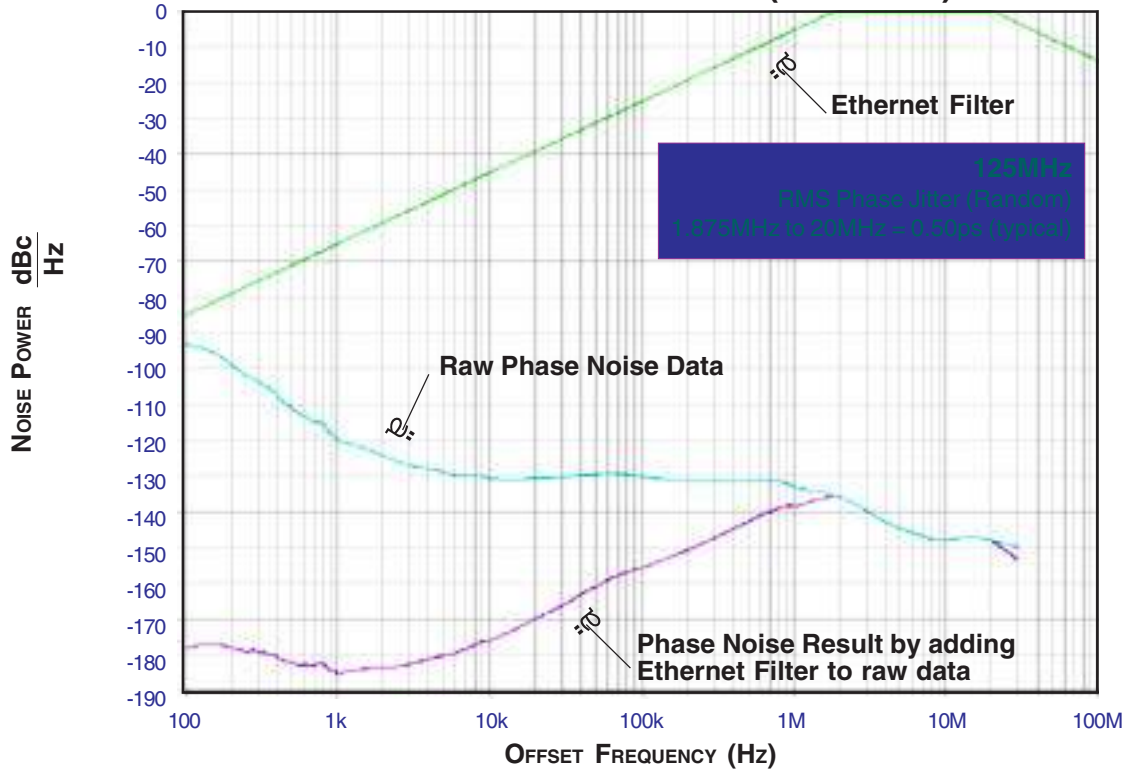



PRELIMINARY

ICS840024I
FEMTOCLOCKS™ CRYSTAL-TO-LVCMOS/LVTTL FREQUENCY SYNTHESIZER

PARAMETER MEASUREMENT INFORMATION

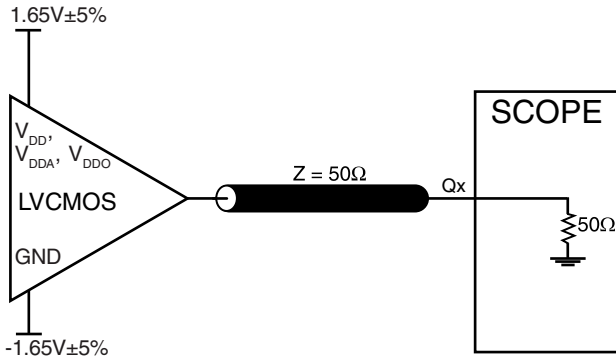

3.3V CORE/3.3V OUTPUT LOAD AC TEST CIRCUIT

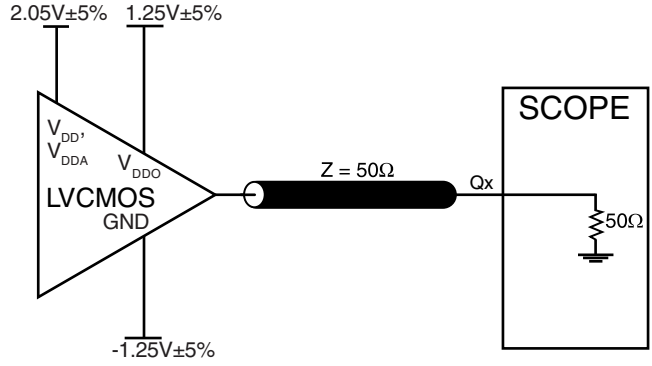

3.3V CORE/2.5V OUTPUT LOAD AC TEST CIRCUIT

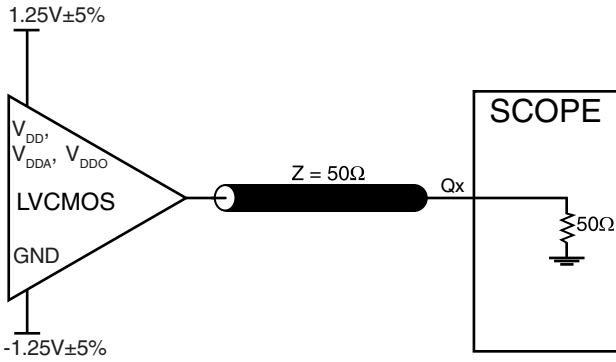

2.5V CORE/2.5V OUTPUT LOAD AC TEST CIRCUIT

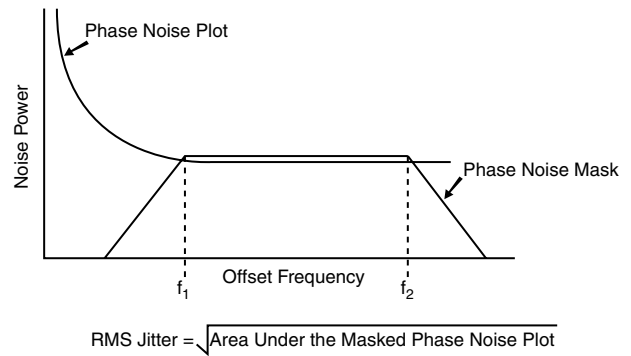

RMS PHASE JITTER

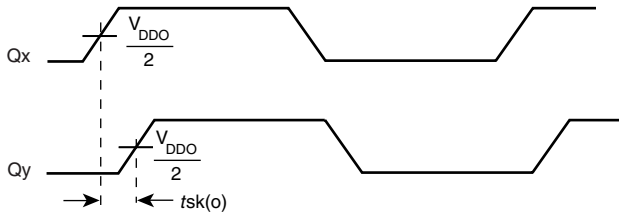

OUTPUT SKEW

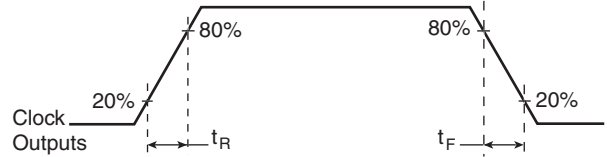

OUTPUT RISE/FALL TIME

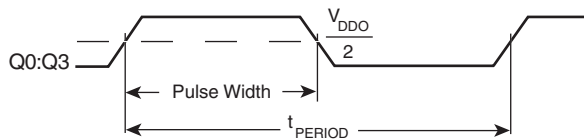

$$odc = \frac{t_{PW}}{t_{PERIOD}}$$

OUTPUT DUTY CYCLE/PULSE WIDTH/PERIOD

APPLICATION INFORMATION

POWER SUPPLY FILTERING TECHNIQUES

As in any high speed analog circuitry, the power supply pins are vulnerable to random noise. The ICS840024I provides separate power supplies to isolate any high switching noise from the outputs to the internal PLL. V_{DD} , V_{DDA} , and V_{DDO} should be individually connected to the power supply plane through vias, and bypass capacitors should be used for each pin. To achieve optimum jitter performance, power supply isolation is required. *Figure 1* illustrates how a 10Ω resistor along with a 10μF and a .01μF bypass capacitor should be connected to each V_{DDA} .

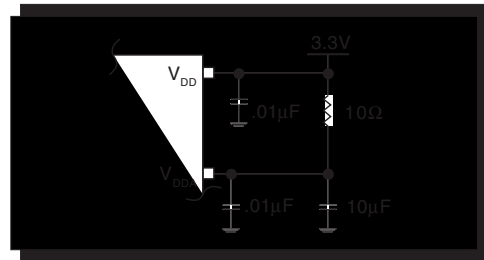

FIGURE 1. POWER SUPPLY FILTERING

CRYSTAL INPUT INTERFACE

The ICS840024I has been characterized with 18pF parallel resonant crystals. The capacitor values shown in *Figure 2*

below were determined using a 25MHz 18pF parallel resonant crystal and were chosen to minimize the ppm error.

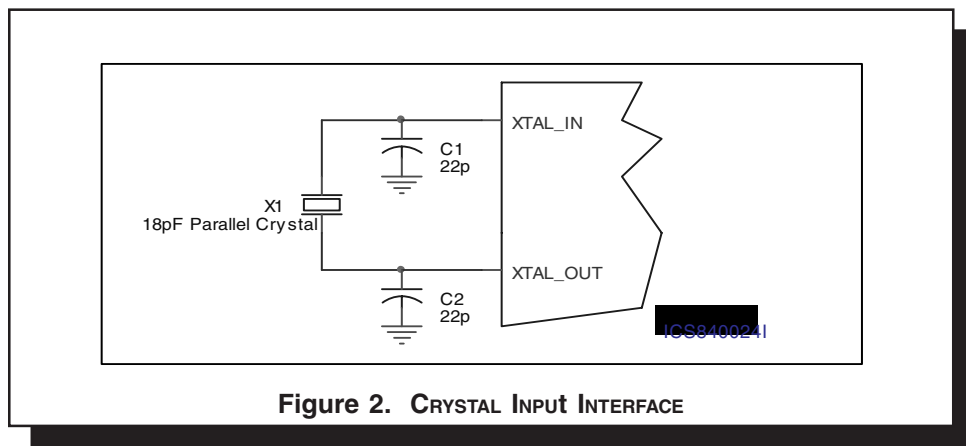

Figure 2. CRYSTAL INPUT INTERFACE



PRELIMINARY

ICS840024I
FEMTOCLOCKS™ CRYSTAL-TO-
LVCMOS/LVTTL FREQUENCY SYNTHESIZER

RELIABILITY INFORMATION

TABLE 6. θ_{JA} VS. AIR FLOW TABLE FOR 20 LEAD TSSOP

θ_{JA} by Velocity (Linear Feet per Minute)			
	0	200	500
Single-Layer PCB, JEDEC Standard Test Boards	114.5°C/W	98.0°C/W	88.0°C/W
Multi-Layer PCB, JEDEC Standard Test Boards	73.2°C/W	66.6°C/W	63.5°C/W

NOTE: Most modern PCB designs use multi-layered boards. The data in the second row pertains to most designs.

TRANSISTOR COUNT

The transistor count for ICS840024I is: 3085



PRELIMINARY

ICS840024I
FEMTOCLOCKS™ CRYSTAL-TO-LVCMOS/LVTTL FREQUENCY SYNTHESIZER

PACKAGE OUTLINE - G SUFFIX FOR 20 LEAD TSSOP

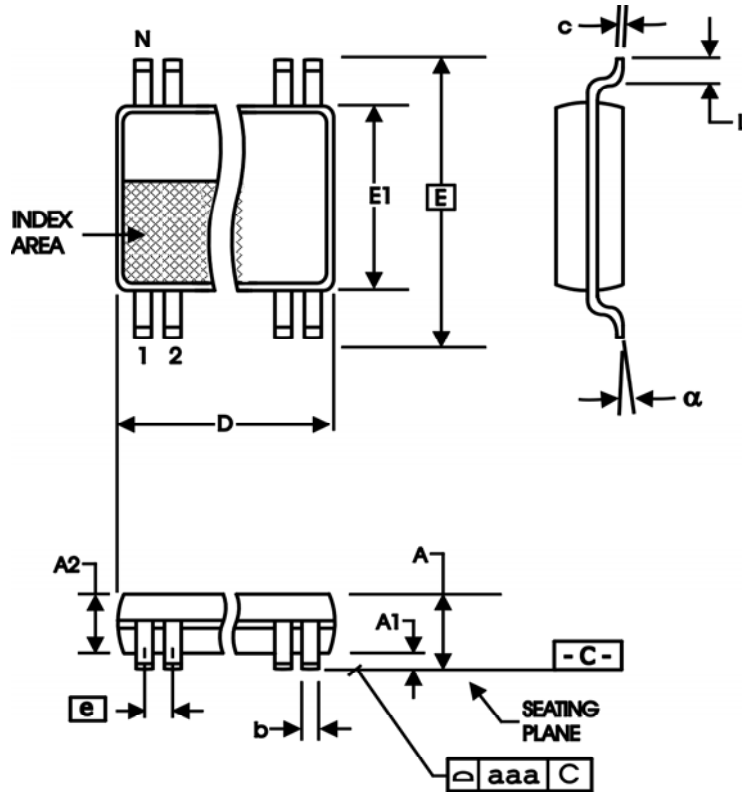

TABLE 7. PACKAGE DIMENSIONS

SYMBOL	Millimeters	
	MIN	MAX
N	20	
A	--	1.20
A1	0.05	0.15
A2	0.80	1.05
b	0.19	0.30
c	0.09	0.20
D	6.40	6.60
E	6.40 BASIC	
E1	4.30	4.50
e	0.65 BASIC	
L	0.45	0.75
alpha	0°	8°
aaa	--	0.10

Reference Document: JEDEC Publication 95, MO-153



PRELIMINARY

ICS840024I
FEMTOCLOCKS™ CRYSTAL-TO-
LVCMOS/LVTTL FREQUENCY SYNTHESIZER

TABLE 8. ORDERING INFORMATION

Part/Order Number	Marking	Package	Shipping Packaging	Temperature
ICS840024AGI	TBD	20 Lead TSSOP	tube	-40°C to 85°C
ICS840024AGIT	TBD	20 Lead TSSOP	2500 tape & reel	-40°C to 85°C
ICS840024AGILF	ICS840024AIL	20 Lead "Lead-Free" TSSOP	tube	-40°C to 85°C
ICS840024AGILFT	ICS840024AIL	20 Lead "Lead-Free" TSSOP	2500 tape & reel	-40°C to 85°C

NOTE: Parts that are ordered with an "LF" suffix to the part number are the Pb-Free configuration and are RoHS compliant.

While the information presented herein has been checked for both accuracy and reliability, Integrated Device Technology, Incorporated (IDT) assumes no responsibility for either its use or for infringement of any patents or other rights of third parties, which would result from its use. No other circuits, patents, or licenses are implied. This product is intended for use in normal commercial and industrial applications. Any other applications such as those requiring high reliability or other extraordinary environmental requirements are not recommended without additional processing by IDT. IDT reserves the right to change any circuitry or specifications without notice. IDT does not authorize or warrant any IDT product for use in life support devices or critical medical instruments.



PRELIMINARY

ICS840024I
FEMTOCLOCKS™ CRYSTAL-TO-
LVCMOS/LVTTL FREQUENCY SYNTHESIZER

REVISION HISTORY SHEET				
Rev	Table	Page	Description of Change	Date
A	T8	17	Ordering Information Table - added lead-free marking.	12/21/07