

1

2

3

4

5

6

7

A

A

B

B

C

C

D

D

E

E

F

F

G

G

H

H

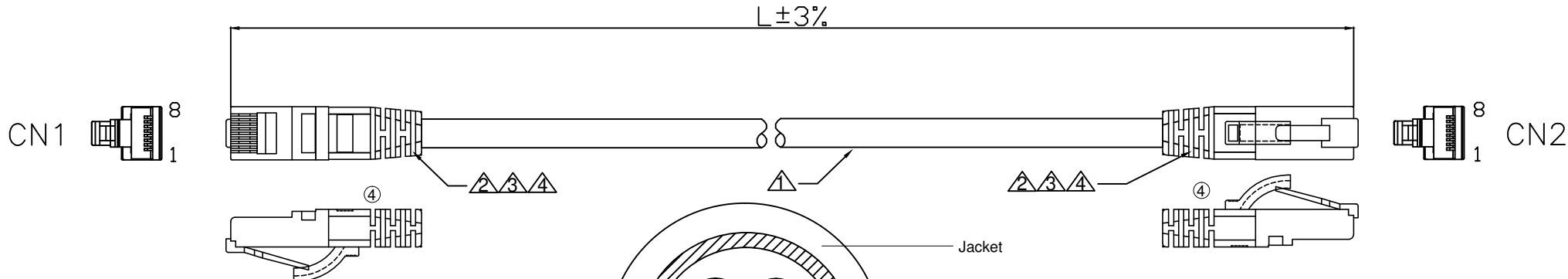

PIN OUT		
CN1	WIRE COLOR	CN2
1	WHITE	1
2	ORANGE	2
3	WHITE	3
6	GREEN	6
4	BLUE	4
5	WHITE	5
7	WHITE	7
8	BROWN	8
SHELL	BRAID	SHELL

⑤ *The PIN OUT is applied to cable length ≥10M

PIN OUT		
CN1	WIRE COLOR	CN2
1	ORANGE/WHITE	1
2	ORANGE	2
3	GREEN/WHITE	3
6	GREEN	6
4	BLUE	4
5	BLUE/WHITE	5
7	BROWN/WHITE	7
8	BROWN	8
SHELL	BRAID	SHELL

⑤ *The PIN OUT is applied to cable length <10M

Electrical test:
Open/short/intermittence: 100%

NO:	NAME	DESCRIPTION	QTY	UNIT
④	AL-FOIL	Double-sided conductive aluminum foil ④	2	PCS
④	Molding	PVC 65P Color: see order code ④	NA	KG
④	CONNECTOR	RJ45 8P8C two fork 3u" gold plated with metal shield	2	PCS
④	CABLE	CAT6a S/FTP (26AWG*1PR+A)*4+B(AM)+PVC OD=5.8±0.3MM Color: see order code ④	NA	MM

WSW order code
AMJS0909-xxxx-xxB-26①

Cable length

0030: 0.3M
0050: 0.5M
0100: 1.0M
0150: 1.5M
0200: 2.0M
0300: 3.0M
0500: 5.0M
0700: 7.0M
1000: 10M
1500: 15M

Cable&Molding color

BK: Black
RD: Red
YE: Yellow
GN: Green
GY: Grey
BU: Blue
WH: White
BN: Brown

RoHS compliant
Unit: mm

Scale	Free	⑤	Add a PIN OUT for cable length ≥10M	22.08.2022	Luca		Date	Name	Customer-No.
TOLERANCE		④	Change the plant	27.07.2022	Luca	Drawn	30.03.2017	Amy	ASSMANN WSW-No. ① AMJS0909-xxxx-xxB-26
		③	Add UL Rating	02.07.2020	Winnie	Approved	22.08.2022	Luca	
		②	Update the Cable specification	16.10.2018	Segal				
DIM		TOL	①	Update the WSW order code	02.06.2017	Amy			Drawing-No.
			①	Drawn	30.03.2017	Amy			ASS 7944 CA
Angle		TOL	Id.	Modification	Date	Name	Replace		Sheet

1

2

3

4

5

6

7