

10/100/1000 BASE-T Dual Port SMD LAN Transformer Module



ALANS10002



27.8 x 12.2 x 7.2 mm
27.9 x 7.5 x 8.6 mm
RoHS/RoHS II Compliant
MSL = 1

Features

- Meets IEEE 802.3ab standards
- Compatible with 10 BASE-T, 100 BASE-TX, and 1000 Base-T
- Operating temperature range up to -40°C to +125°C
- RoHS Compliant
- High performance magnetics for EMI suppression and common mode noise rejection
- Multiple schematic and pinout options
- 1CT:1CT TX and RX Transformers

Applications

- Fast and gigabit Ethernet
- Servers, switches and routers
- IP cameras, surveillance, and phone
- Access points
- Industrial computers and robotics
- Networking and communications
- Broadcast video
- Set top box

Part Identification

ALANS10002 - [] [] [] []

Package Size
6: 48-Pin
7: 50-Pin

Schematic	
48-Pin	50-Pin
NA1	PA1
N11	P11
N41	

Operating Temp.
E: 0 °C to +70 °C
D: -40 °C to +85 °C
J: -40 °C to +105 °C
K: -40 °C to +125 °C

Packaging
B: Bulk
T: Tape and Reel**

**Package size "6: 48-Pin": T= 300 pcs/reel

**Package size "7: 50-pin": T= 400 pcs/reel

10/100/1000 BASE-T Dual Port SMD LAN Transformer Module

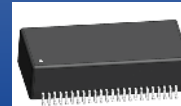

ALANS10002



27.8 x 12.2 x 7.2 mm
27.9 x 7.5 x 8.6 mm
RoHS/RoHS II Compliant
MSL = 1

Electrical Specifications at 25°C

Part Number	Insertion Loss (dB Max)	Return Loss (dB Min)				Crosstalk (dB Min)			CMRR (dB Min)			DCMR (dB Min)		
	0.1-100 MHz	30 MHz	60 MHz	80 MHz	100 MHz	30 MHz	60 MHz	100 MHz	30 MHz	60 MHz	100 MHz	30 MHz	60 MHz	100 MHz
ALANS10002-6NA1	0.8	18	15	12	10	44	38	34	45	40	35	46	38	33
ALANS10002-6N11	0.8	18	15	12	10	44	38	34	45	40	35	46	38	33
ALANS10002-6N41	0.8	18	15	12	10	44	38	34	45	40	35	46	38	33
ALANS10002-7NA1	0.8	18	15	12	10	44	38	34	45	40	35	46	38	33
ALANS10002-7N11	0.8	18	15	12	10	44	38	34	45	40	35	46	38	33

Part Number	Inductance (uH Min)	Leakage Inductance (uH Max)	Interwinding Capacitance (pF Max)	DC Resistance (Ω Max)		Hi Pot (VDC)	Weight (g)
				Primary	Secondary		
Test Condition	@100kHz, 0.1V, 8mA DC Bias	@100kHz, 0.1V TD to MX	@100kHz, 0.1V TD to MX			6 sec.	Per Piece
ALANS10002-6NA1	350	0.35	35	1.2	0.9	2500	3.2
ALANS10002-6N11	350	0.35	35	0.9	1.2	2500	3.2
ALANS10002-6N41	350	0.35	35	1.2	0.9	2500	3.2
ALANS10002-7NA1	350	0.35	35	1.2	0.9	2500	2.2
ALANS10002-7N11	350	0.35	35	0.9	1.2	2500	2.2

10/100/1000 BASE-T Dual Port SMD LAN Transformer Module



ALANS10002



27.8 x 12.2 x 7.2 mm
27.9 x 7.5 x 8.6 mm
RoHS/RoHS II Compliant
MSL = 1

Mechanical Dimensions

6: 48-pin

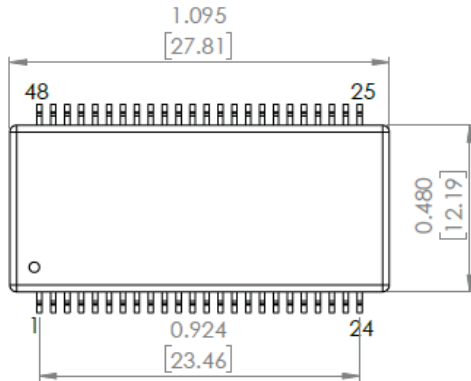

TOP VIEW

RECOMMENDED LAND PATTERN

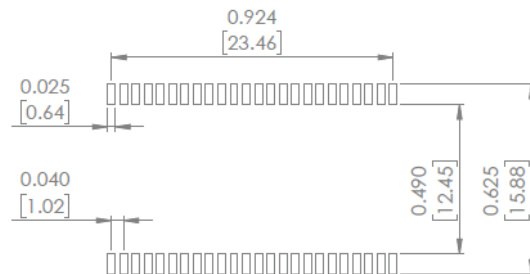

FRONT VIEW

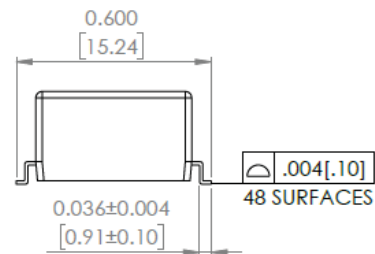

SIDE VIEW

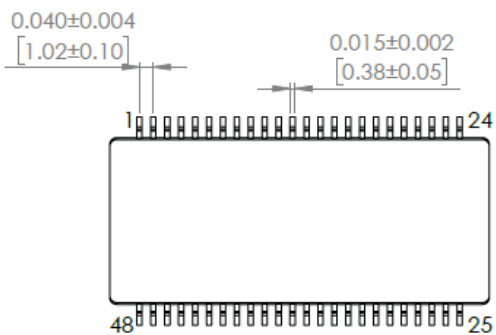

BOTTOM VIEW

Unless otherwise specified, all tolerances are ± 0.25 in mm
Dimensions: inch/ [mm]



5101 Hidden Creek Ln Spicewood TX 78669
Phone: 512-371-6159 | Fax: 512-351-8858
For terms and conditions of sales, please visit:
www.abracon.com

REVISED: 08-5-19

ABRACON IS
ISO9001-2015
CERTIFIED

10/100/1000 BASE-T Dual Port SMD LAN Transformer Module



ALANS10002



27.8 x 12.2 x 7.2 mm
27.9 x 7.5 x 8.6 mm
RoHS/RoHS II Compliant
MSL = 1

Mechanical Dimensions

7: 50-pin

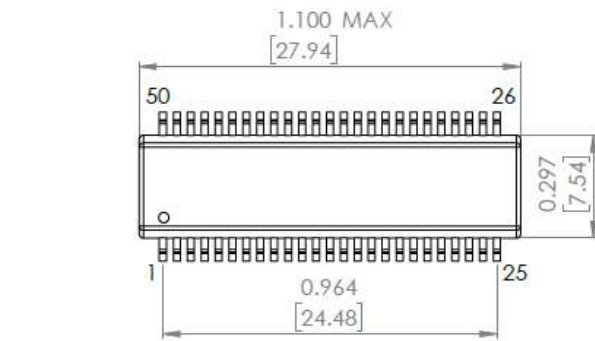

TOP VIEW

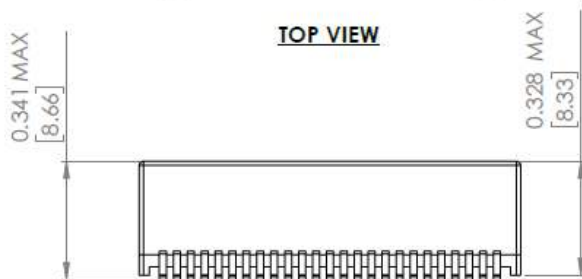

FRONT VIEW

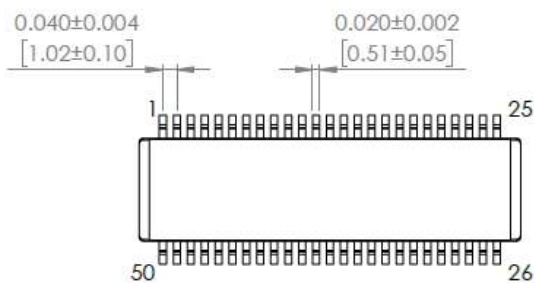

BOTTOM VIEW

RECOMMENDED LAND PATTERN

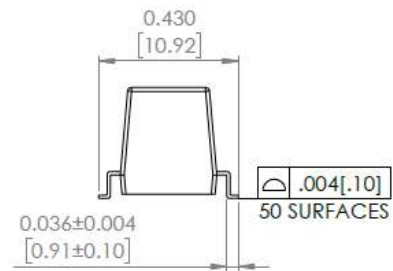
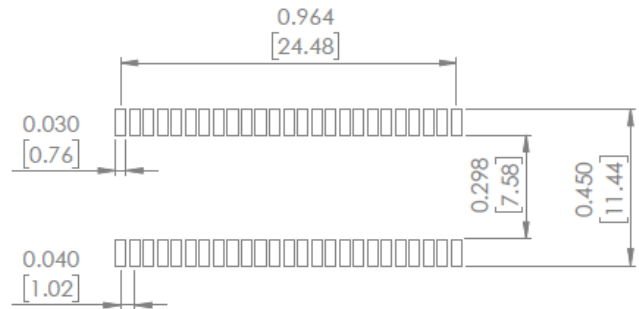

SIDE VIEW

Unless otherwise specified, all tolerances are ± 0.25 in mm
Dimensions: inch/ [mm]



5101 Hidden Creek Ln Spicewood TX 78669
Phone: 512-371-6159 | Fax: 512-351-8858
For terms and conditions of sales, please visit:
www.abracon.com

REVISED: 08-5-19

ABRACON IS
ISO9001-2015
CERTIFIED

10/100/1000 BASE-T Dual Port SMD LAN Transformer Module



ALANS10002



27.8 x 12.2 x 7.2 mm
27.9 x 7.5 x 8.6 mm
RoHS/RoHS II Compliant
MSL = 1

Schematics

48-Pin

NA1

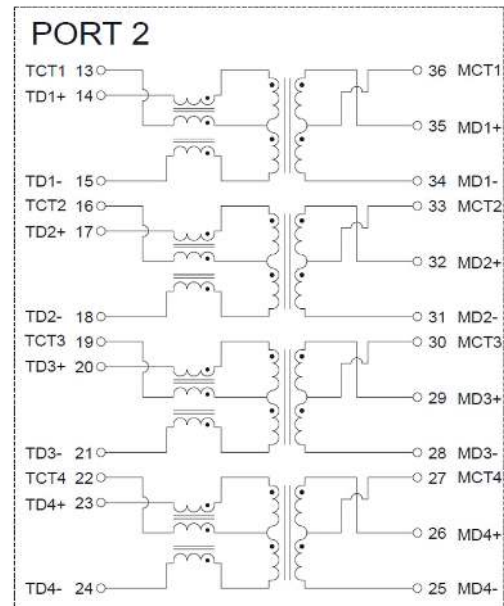
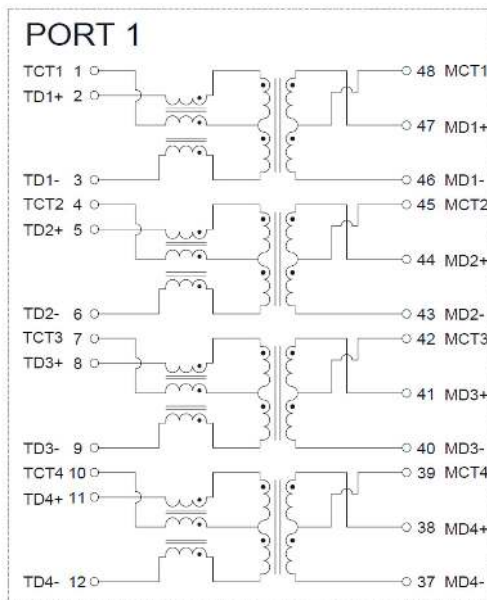

N11

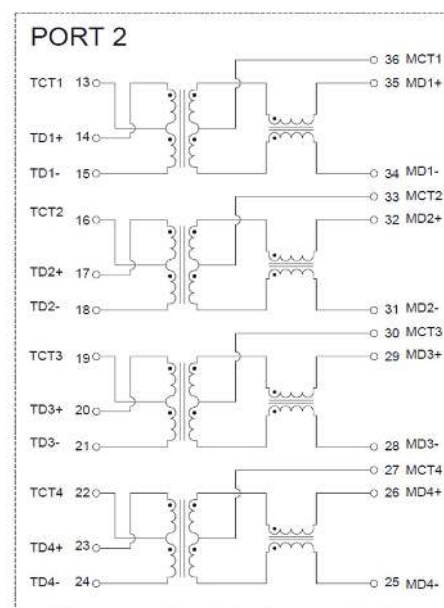
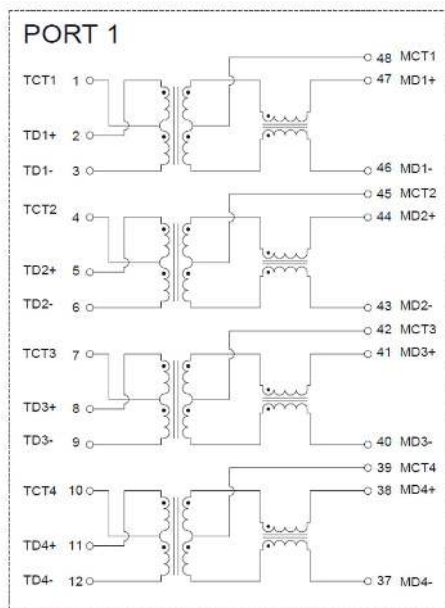

Contact Abracon for additional options.



5101 Hidden Creek Ln Spicewood TX 78669
Phone: 512-371-6159 | Fax: 512-351-8858
For terms and conditions of sales, please visit:
www.abracon.com

REVISED: 08-5-19

ABRACON IS
ISO9001-2015
CERTIFIED

10/100/1000 BASE-T Dual Port SMD LAN Transformer Module



ALANS10002



27.8 x 12.2 x 7.2 mm
27.9 x 7.5 x 8.6 mm
RoHS/RoHS II Compliant
MSL = 1

Schematics

48-Pin

N41

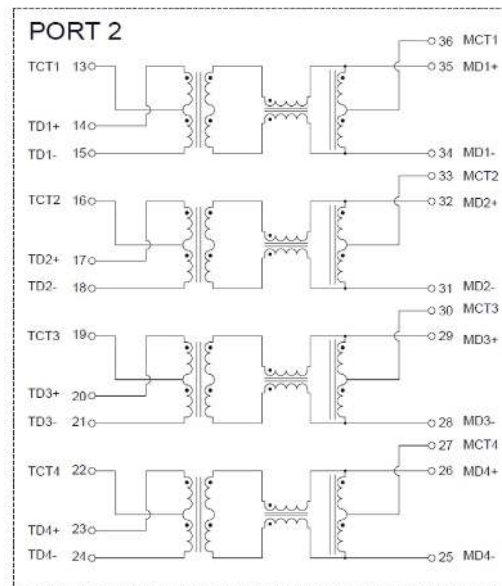
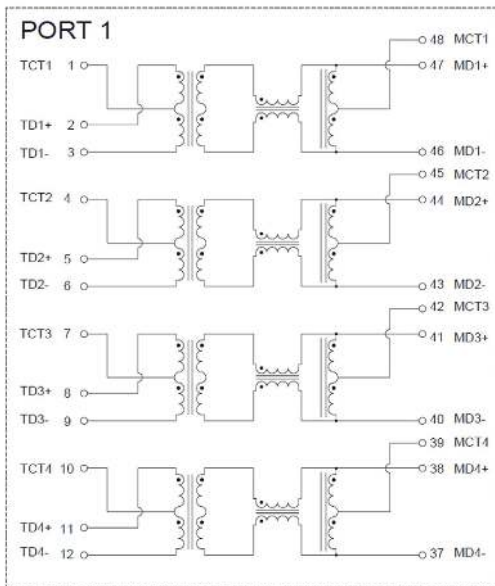

Contact Abracon for additional options.



5101 Hidden Creek Ln Spicewood TX 78669
Phone: 512-371-6159 | Fax: 512-351-8858
For terms and conditions of sales, please visit:
www.abracon.com

REVISED: 08-5-19

ABRACON IS
ISO9001-2015
CERTIFIED

10/100/1000 BASE-T Dual Port SMD LAN Transformer Module



ALANS10002



27.8 x 12.2 x 7.2 mm
27.9 x 7.5 x 8.6 mm
RoHS/RoHS II Compliant
MSL = 1

Schematics

50-Pin

PA1

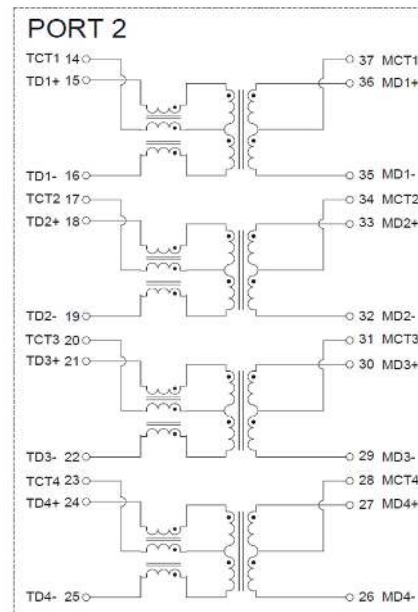
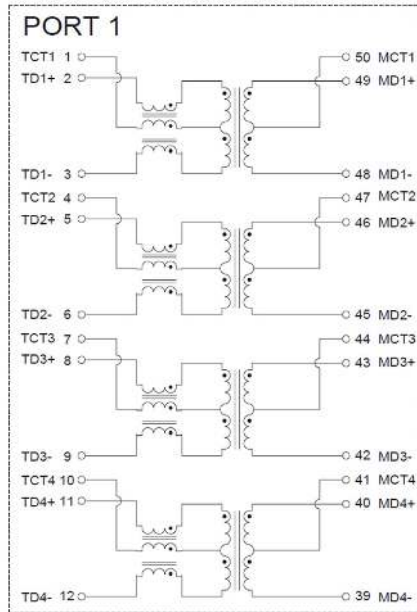

P11

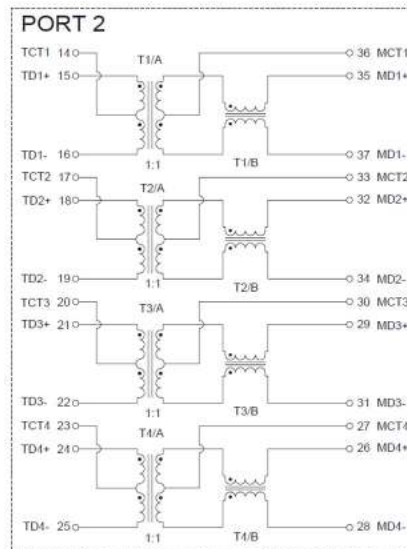
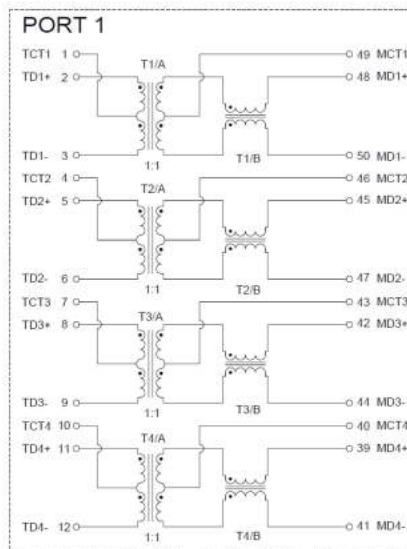

Contact Abracon for additional options.



5101 Hidden Creek Ln Spicewood TX 78669
Phone: 512-371-6159 | Fax: 512-351-8858
For terms and conditions of sales, please visit:
www.abracon.com

REVISED: 08-5-19

ABRACON IS
ISO9001-2015
CERTIFIED

10/100/1000 BASE-T Dual Port SMD LAN Transformer Module



ALANS10002



27.8 x 12.2 x 7.2 mm
 27.9 x 7.5 x 8.6 mm
 RoHS/RoHS II Compliant
 MSL = 1

Reflow Profile

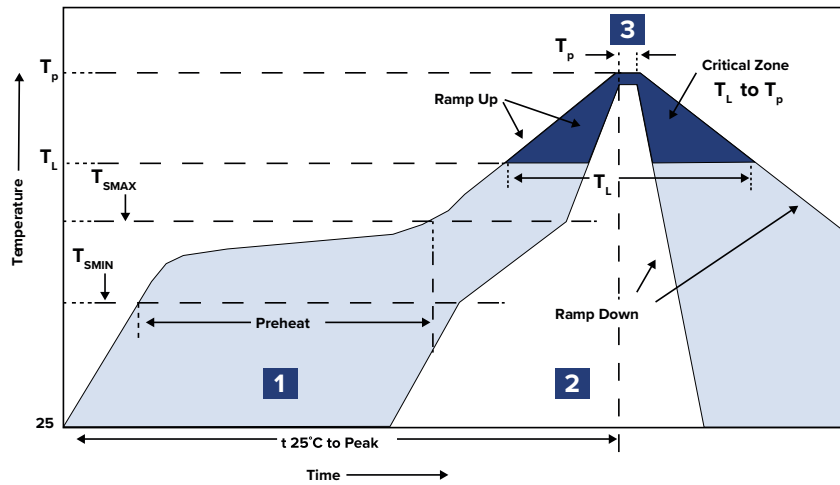

Zone	Description	Temperature	Time
1	Preheat / Soak	$T_{SMIN} \sim T_{SMAX}$ 150°C ~ 200°C	60 ~ 120 sec.
2	Reflow	T_L 217°C	60 ~ 150 sec.
3	Peak heat	T_P 245°C	20 sec. MAX

10/100/1000 BASE-T Dual Port SMD LAN Transformer Module



ALANS10002



27.8 x 12.2 x 7.2 mm
27.9 x 7.5 x 8.6 mm
RoHS/RoHS II Compliant
MSL = 1

Packaging

Package size option 6:

Tape and Reel: 300 pcs
Pieces per Carton: 1,800 pcs/box
T&R per Carton: 6 T&R/box
Weight per Carton: 10.1kg
Weight per Piece: 3.2g

Mechanicals

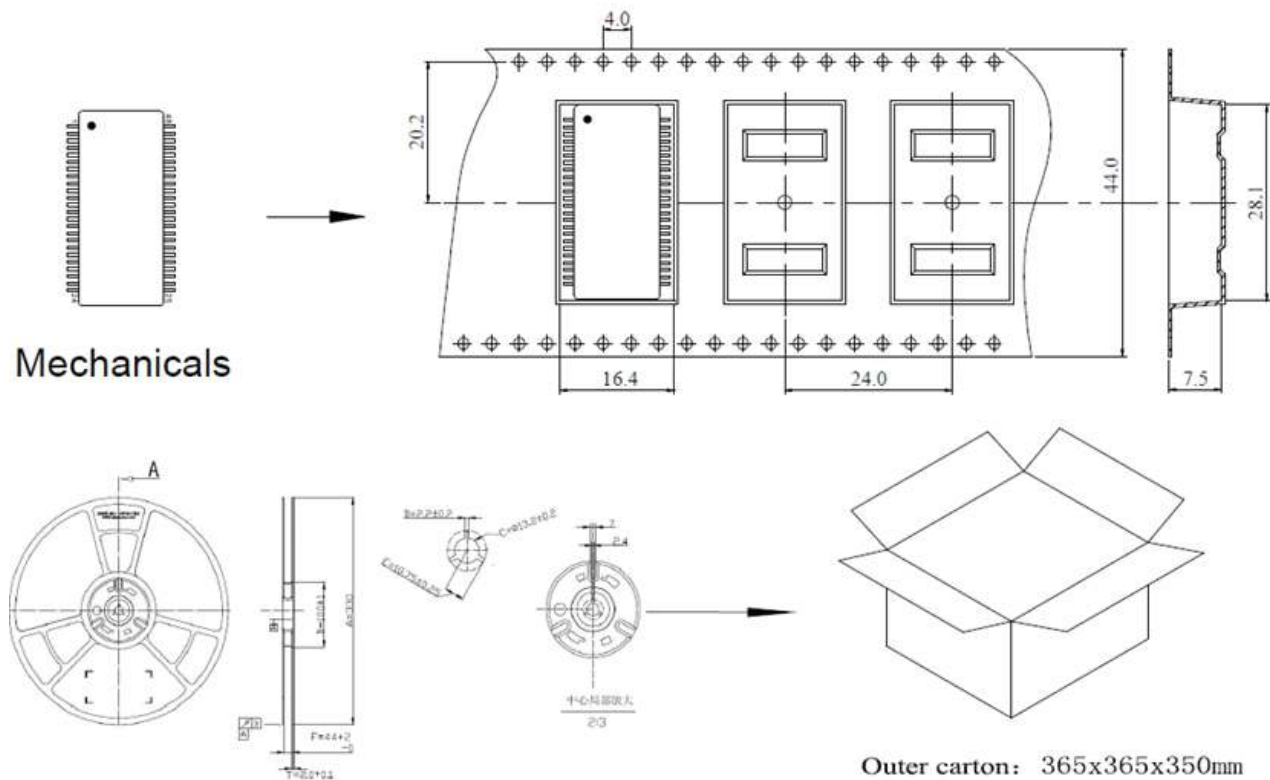

Dimensions: mm



5101 Hidden Creek Ln Spicewood TX 78669
Phone: 512-371-6159 | Fax: 512-351-8858
For terms and conditions of sales, please visit:
www.abracon.com

REVISED: 08-5-19

ABRACON IS
ISO9001-2015
CERTIFIED

10/100/1000 BASE-T Dual Port SMD LAN Transformer Module



ALANS10002



27.8 x 12.2 x 7.2 mm
27.9 x 7.5 x 8.6 mm
RoHS/RoHS II Compliant
MSL = 1

Packaging

Package size option 7:

Tape and Reel: 400 pcs
Pieces per Carton: 2,400 pcs/box
T&R per Carton: 6 T&R/box
Weight per Carton: 10.0kg
Weight per Piece: 2.2g

Mechanicals

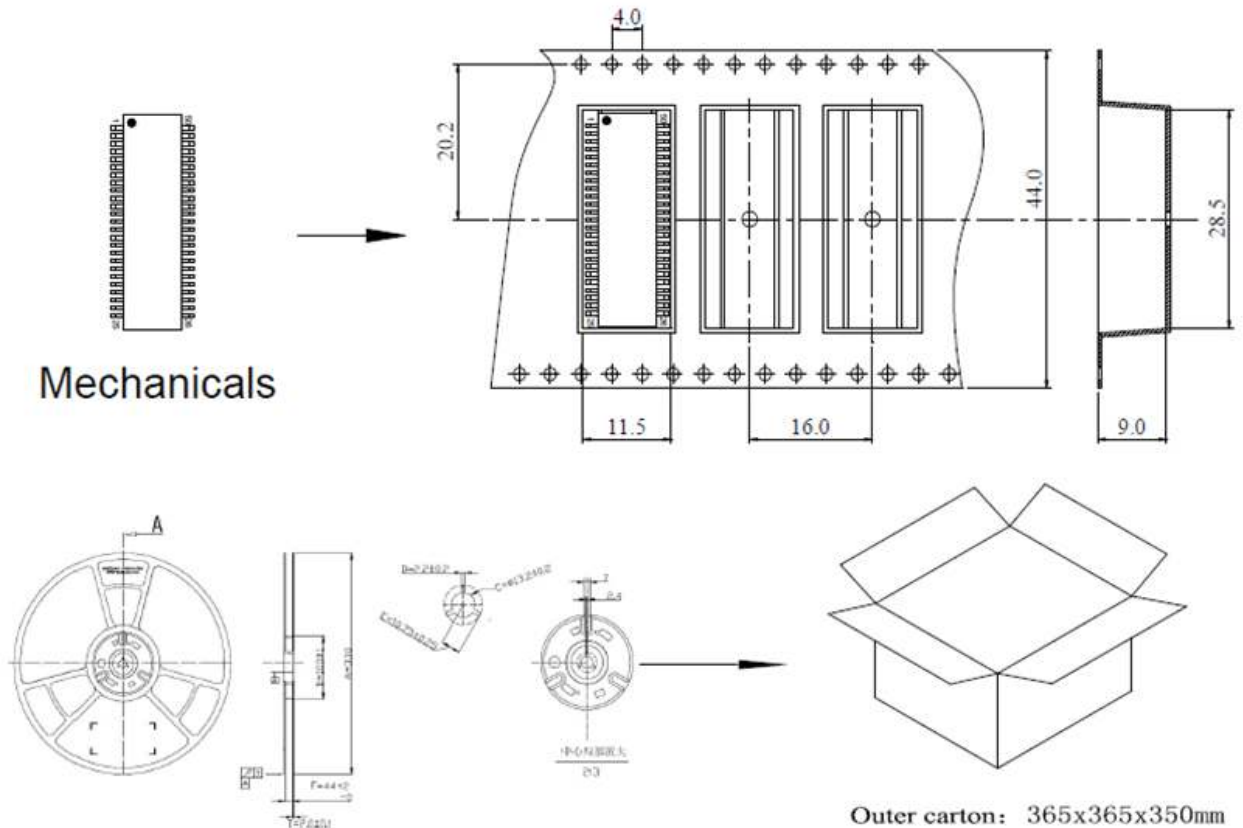

Dimensions: mm

ATTENTION: Abracon LLC's products are COTS – Commercial-Off-The-Shelf products; suitable for Commercial, Industrial and, where designated, Automotive Applications. Abracon's products are not specifically designed for Military, Aviation, Aerospace, Life-dependent Medical applications or any application requiring high reliability where component failure could result in loss of life and/or property. For applications requiring high reliability and/or presenting an extreme operating environment, written consent and authorization from Abracon LLC is required. Please contact Abracon LLC for more information.



5101 Hidden Creek Ln Spicewood TX 78669
Phone: 512-371-6159 | Fax: 512-351-8858
For terms and conditions of sales, please visit:
www.abracon.com

REVISED: 08-5-19

ABRACON IS
ISO9001-2015
CERTIFIED